

FAAC

DSL2000 Slide Gate Operator

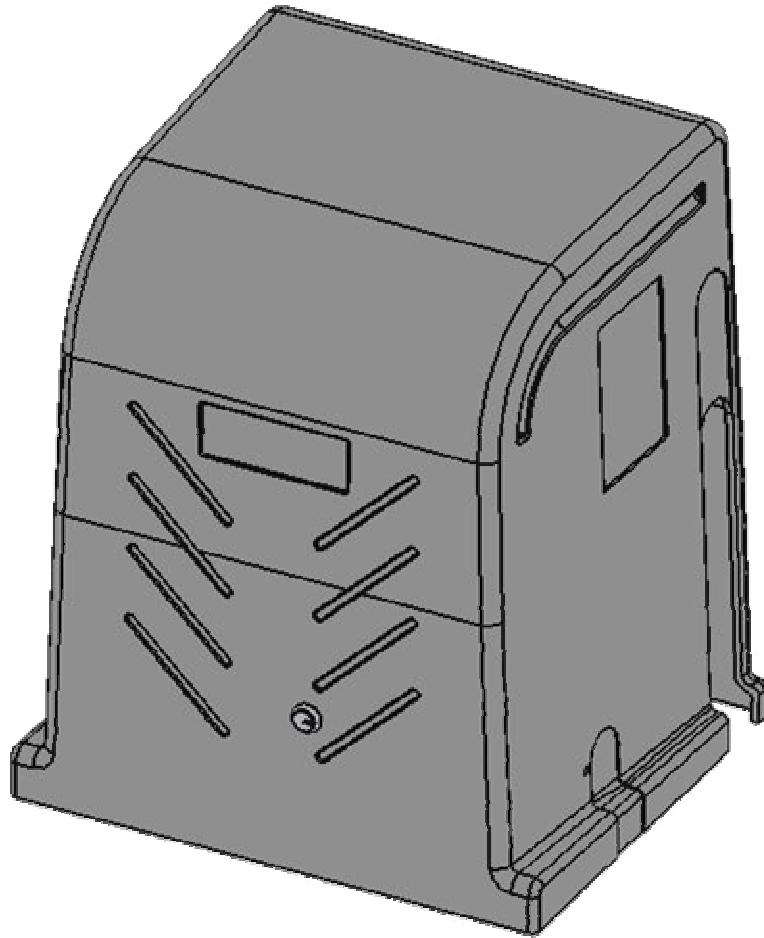

American Built

FAAC International
5151 Sunbeam Road
Suites 9-11
Jacksonville, FL 32257
www.faacusa.com

FAAC

TABLE OF CONTENTS

IMPORTANT SAFETY INFORMATION

Important User Instructions 3
 Restrictions & Warnings 3
 Internal Entrapment Prevention 5
 External Entrapment Prevention 5
 UL325 Gate Operator Classification 6
 Glossary Of Terms 6
 Warning Sign Installation 7
 Installation Precautions 7

GATE OPERATOR INSTALLATION

PreInstallation Guidelines 8
 Gate Operator Location 8
 Concrete Pad Size & Location 9
 Gate Operator Bolt Down 10
 Chain Connection - Front Mount 10
 Chain Connection - Rear Mount 11
 Limit Switch Setup 12
 Gate Operator Direction 12

ELECTRICAL INSTALLATION

Power Switch Location 13
 AC Power Guidelines 13
 AC Power Connection 13
 Battery Power Connection 14
 Accessory Power 14
 Master/Slave Connection 15

GATE OPERATOR ADJUSTMENTS

Reverse Sensitivity Adjustment 16
 Reverse Sensitivity Shutdown 16
 Close Time Delay Adjustment 17
 DIP Switch Settings 17

ACCESSORY CONNECTIONS

Accessory Wire Overview 18
 Edge Sensor Connections 19
 Photo Sensor Connections 20
 Standard Reverse Connections 21
 Open, Close, Stop Connections 21
 External Reset Connection 21
 Access Control Connection 22
 Fire Lock Connection 22
 Radio Receiver Connections 23
 MagLock & Solenoid Lock Connections 23
 Alarm & Warning Light Connections 24
 Solar Panel Connections 24

LOOP & LOOP DETECTORS

Basic Loop Layout 25
 Loop Installation Guidelines 25
 Plug-In Loop Detector Connections 26
 External Loop Detector Connections 26

TROUBLESHOOTING TIPS

Fault Light Count 26

 **Read and follow all U.L. and Safety Standards before installing any access device. Please refer to this manual and qualified personnel for assistance. DO NOT install this device unless all entrapment and pinch points are eliminated.**

IMPORTANT SAFETY INFORMATION



WARNING: A moving gate can cause serious injury or death. Read and follow all Installation Manual, Reference Manual, and Warning Label Instructions.

IMPORTANT USER INSTRUCTIONS:

Automatic gate systems provide user convenience and limit vehicular traffic. Because these systems can produce high levels of force, it is important that you are aware of the potential hazards associated with the system. Potential hazards may include pinch points, entrapment positions, lack of proper pedestrian access, blind spots for traffic visibility.

It is the joint responsibility of the designer, purchaser, installer and end user to verify the system is properly configured for its intended use. Be sure that the installer has instructed you on the proper operation of the gate and gate system before use. Be sure the installer trains you about the basic functions of the required reversing devices associated with the gate system and how to properly test them. Reversing devices may include reverse loops, sensing edges, photoelectric cells, inherent reverse detection, and/or other external devices.

All users should follow and understand the following points:

- Carefully read and follow all instructions in this manual and keep it in a safe place for future reference.
- Carefully read and follow the **Restrictions & Warnings** section of this manual.
- Carefully read and follow the **Entrapment Prevention** section of this manual.
- Carefully read and understand the **Glossary of Terms** section of this manual.
- Make sure that all residents and users are familiar with the proper use of the gate system and its potential hazards.
- Make sure proper reversing devices are installed on all gates to avoid all potential hazards and entrapment.
- Understand loops and loop detectors, photoelectric cells and other devices must be installed with this gate operator to prevent the gate from closing on vehicles.
- Installation, service and maintenance must be carried out by qualified personnel.
- Understand the manufacturer can not be held responsible for damage or injury caused by improper, erroneous or unreasonable use. Failure to comply with these guidelines may create a dangerous situation and will void any and all warranties.
- Always consult your qualified dealer if any concerns or questions arise.

RESTRICTIONS & WARNINGS:

WARNING - To reduce the risk of injury or death:

1. READ AND FOLLOW ALL INSTRUCTIONS.
2. Never let children operate or play with gate controls. Keep the remote control away from children. Never allow children to play in the area of the gate system.
3. Always keep people and objects away from gate. **NO ONE SHOULD CROSS THE PATH OF THE MOVING GATE!**
4. Test the operator monthly. The gate **MUST** reverse on contact with a rigid object or stop or reverse when an object activates the non-contact sensors. After adjusting the force or the limit of travel, retest the gate operator. Failure to adjust and retest the gate operator properly can increase the risk of injury or death. If any reverse device functions improperly, remove the operator from service immediately.
5. **KEEP GATES PROPERLY MAINTAINED.** Read the owner's manual. Have a qualified service person make repairs to gate hardware.
6. The entrance is for vehicles only. Pedestrians must use separate entrance. Keep all pedestrian traffic away from the gate.
7. Use the emergency release/shut off only when the gate is not moving. Make sure the power for the gate operator is off by using the On/Off switch located inside the cover on the left side of the controller.
8. Every gate operator installation **MUST** have secondary protection devices against entrapment, such as edge sensors and photoelectric cells more in particularly in places where the risk of entrapment is more likely to occur. Proper reversing devices **MUST** be installed on all gates to avoid all potential hazards and entrapment.
9. **SAVE THESE INSTRUCTIONS**



WARNING: DO NOT INSTALL this product unless all safety standards are followed and all entrapment and pinch points have been eliminated.

IMPORTANT SAFETY INFORMATION

RESTRICTIONS & WARNINGS:

Install the gate operator only if:

1. The gate operator is appropriate for the construction of the gate and the usage Class of the application. Make sure the gate is within the weight and length limitations specified for the operator.
2. All openings of a horizontal slide gate are guarded or screened from the bottom of the gate to a minimum of 4 feet (1.2m) above the ground to prevent a 2 1/4 inch (57.15mm) diameter sphere from passing through the openings anywhere in the gate, and in that portion of the adjacent fence that the gate covers in the open position.
3. ALL EXPOSED PINCH POINTS ARE ELIMINATED OR GUARDED AND GUARDING IS SUPPLIED FOR EXPOSED ROLLERS. DO NOT INSTALL THIS DEVICE UNLESS ALL ENTRAPMENT AND PINCH POINTS ARE ELIMINATED!
4. The operator is intended for installation only on slide gates used to control vehicles. Pedestrians must be provided with a separate access opening.
5. The gate must be installed in a location so that enough clearance is provided between the gate and adjacent structures when opening and closing to reduce the risk of entrapment. Gates should not open into public access areas.
6. The gate must be properly installed and work freely in both directions prior to the installation of the gate operator. DO NOT REDUCE REVERSING SENSITIVITY TO COMPENSATE FOR A DAMAGED GATE.
7. Gate operator controls must be placed far enough from the gate to prevent the user from coming in contact with the gate while operating the controls. All activating devices must be installed in a clear line-of-sight with the gate and its travel. Controls intended to be used to reset an operator after two sequential activations of the entrapment protection device must be located in the line-of-sight of the gate. Outdoor or easily accessible controls shall have a security feature to prevent unauthorized use.
8. Warning signs must be permanently installed on both sides of the gate and must be fully visible to traffic and pedestrians.
9. Install the gate system and gate in accordance with ASTM F220-02: Standard Specification for Automated Vehicular Gate Construction. For a copy of this standard, contact ASTM at (610) 832-9585, service@astm.org, or www.astm.org. Install the gate system and gate in accordance with UL325 standards.

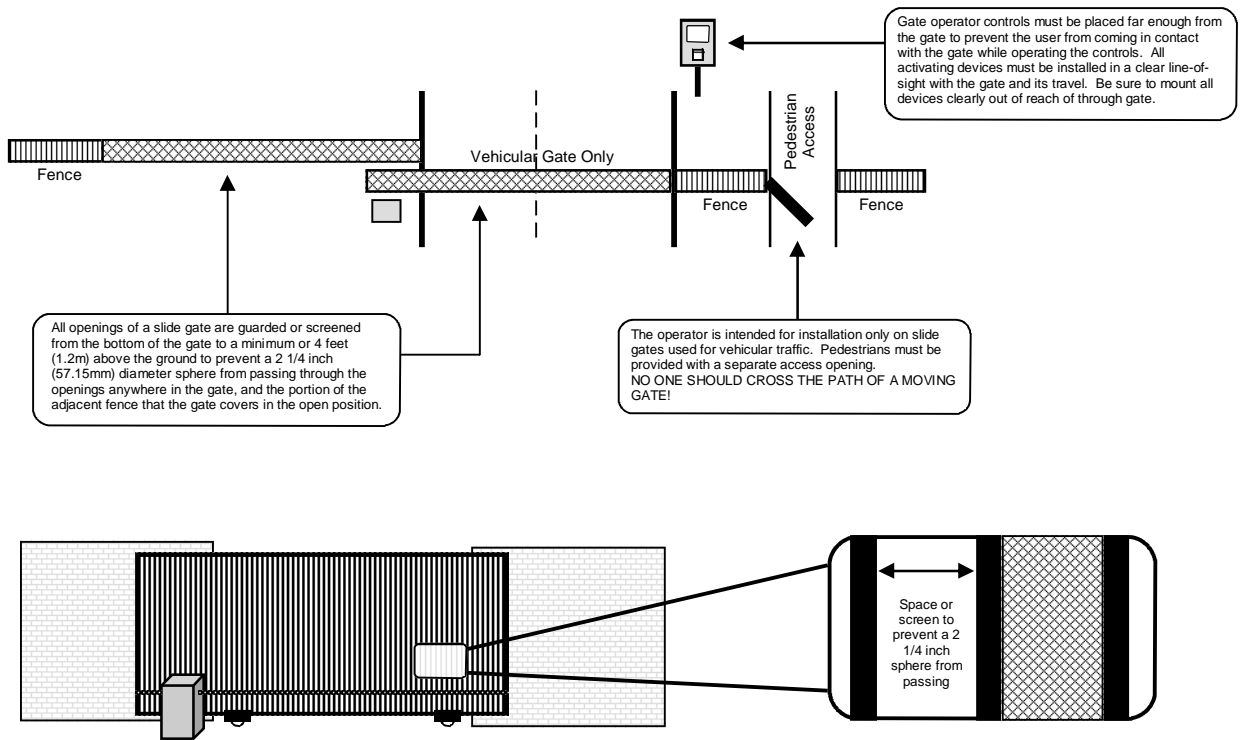

⚠ WARNING: DO NOT INSTALL this product unless all safety standards are followed and all entrapment and pinch points have been eliminated.

IMPORTANT SAFETY INFORMATION

INTERNAL ENTRAPMENT PREVENTION:

This vehicular gate operator is equipped with an inherent (Type A) entrapment sensing device. The system will sense an obstruction in both the open and close cycles, and will reverse the direction of the gate travel upon encountering an obstruction. If the system detects a second obstruction before reaching the full open or close limit after the initial reversal, a warning alarm will activate and the operator will require a reset before resuming normal operation. This is called a **Hard Shutdown**. Please read and follow the **Shutdown Conditions** section of this manual for more directions.

EXTERNAL ENTRAPMENT PREVENTION:

Non-contact and/or contact sensors must be installed to provide external entrapment prevention in accordance with UL325 section 3.1. Use only UL325 compliant devices and low voltage (24V) devices. Carefully follow the installation manual for the UL325 device used for installation, usage, and maintenance.

Non-Contact Sensors (Photo Beams):

Non-contact sensors generally are photoelectric cells or like devices. For gate operators utilizing non-contact sensors:

1. Refer to the diagram below for placement of non-contact sensors.
2. Use care to reduce the risk of nuisance tripping, such as when a vehicle trips the sensor while the gate is still moving.
3. One or more non-contact sensors shall be located where a risk of entrapment or obstruction exists, such as the perimeter reachable by a moving gate or barrier. Use caution when installing non-contact sensors since some devices only cover a select area. For example, a photo beam will not cover the full height of a gate/fence area. Refer to the diagram below.

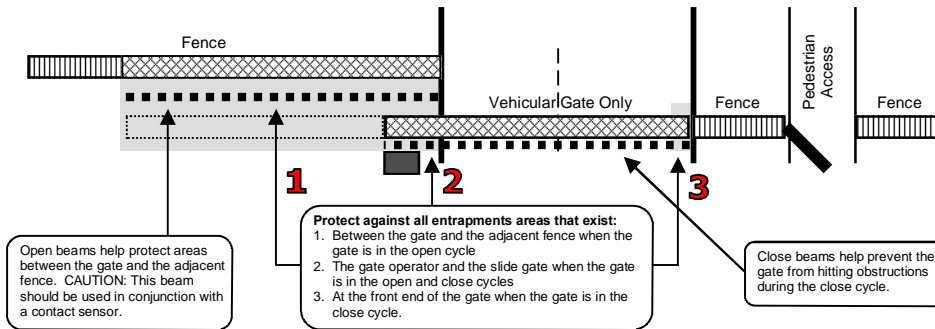

Contact Sensors (Edge Sensors):

Contact sensors generally are sensing edges or like devices. For gate operators utilizing contact sensors:

1. Refer to the diagram below for placement of contact sensors.
2. One or more contact sensors shall be located where the risk of entrapment or obstruction exists, such the leading edge, trailing edge, and posts mounted inside and outside of the vehicular slide gate and motor.
3. Hardwired contact sensors shall be located and its wiring arranged so the communication between the sensor and the gate operator is not subject to any mechanical damage.
4. Wireless contact sensors such as ones that transmit radio frequency (RF) signals to the gate operator for entrapment prevention functions shall be located where the transmission of the signals are not obstructed or impeded by building structures, landscaping or similar obstructions. All wireless contact sensors shall function under the intended end-use conditions.

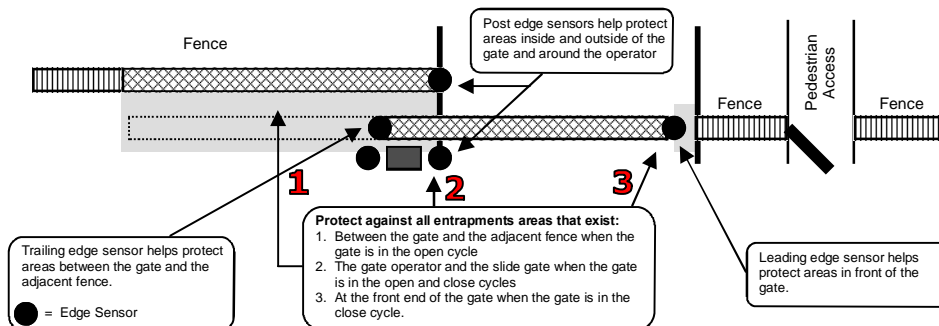

IMPORTANT SAFETY INFORMATION

! IMPORTANT: Make sure the gate operator usage classification is correct for the site and the type of gate.

UL325 GATE OPERATOR CLASSIFICATION:

RESIDENTIAL VEHICULAR GATE OPERATOR

CLASS I: A vehicular gate operator (or system) intended for use in a home of one to four single family dwelling, or a garage or parking area associated therewith.

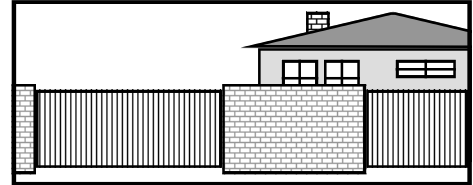

COMMERCIAL/GENERAL ACCESS VEHICULAR GATE OPERATOR

CLASS II: A vehicular gate operator (or system) intended for use in a commercial location or building such as a multi-family housing unit (five or more single family units), hotels, garages, retail store, or other building servicing the general public.

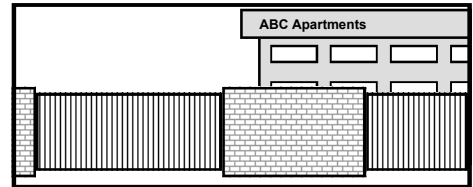

INDUSTRIAL/LIMITED ACCESS VEHICULAR GATE OPERATOR

CLASS III: A vehicular gate operator (or system) intended for use in an industrial location or building such as a factory or lading dock area or other locations not intended to service the general public.

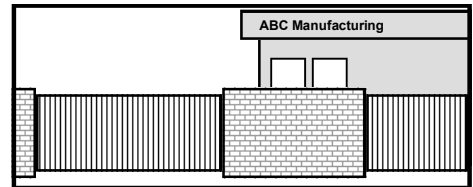

RESTRICTED ACCESS VEHICULAR GATE OPERATOR

CLASS IV: A vehicular gate operator (or system) intended for use in a guarded industrial location or building such as an airport security area or other restricted access locations not servicing the general public, in which unauthorized access is prevented via supervision by security personnel.

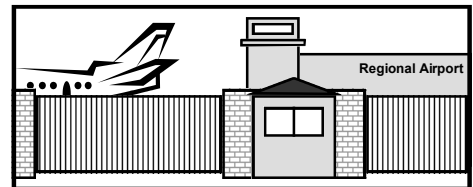

GLOSSARY OF TERMS:

GATE: A moving barrier such as a swinging, sliding, raising, lowering, or the like, barrier, that is a stand-alone passage barrier or is that portion of a wall or fence system that controls entrance and/or egress by people or vehicles and completes the perimeter of a defined area.

VEHICULAR HORIZONTAL SLIDE GATE OPERATOR (Or System): A vehicular gate operator (or system) that controls a gate which slides in a horizontal direction that is intended for use for vehicular entrance or exit to a drive, parking lot, or the like.

ENTRAPMENT: A condition when a object is caught or held in a position that increases the risk of injury or death.

INHERENT ENTRAPMENT SENSING DEVICE: An automatic sensor system, which senses entrapment of a solid object and is incorporated as a permanent and integral part of the gate operator.

NON-CONTACT SENSOR: External device such as a photoelectric cell used to provide entrapment prevention and located where a risk of entrapment or obstruction exists.

CONTACT SENSOR: External device such as a edge sensor used to provide entrapment prevention located where a risk of entrapment or obstruction exists such as the leading edge, trailing edge, and posts mounted inside and outside of the vehicular slide gate and motor.

IMPORTANT SAFETY INFORMATION

WARNING SIGN INSTALLATION:

This vehicular gate operator is supplied with two warning signs to alert people that a potential hazard may exist and that appropriate action should be taken to reduce the risk of hazard, injury or death.

1. Warning signs must be permanently installed on both sides of the gate and must be fully visible to traffic and pedestrians.
2. Use appropriate hardware such as metal screws (not supplied) to permanently install each warning sign.

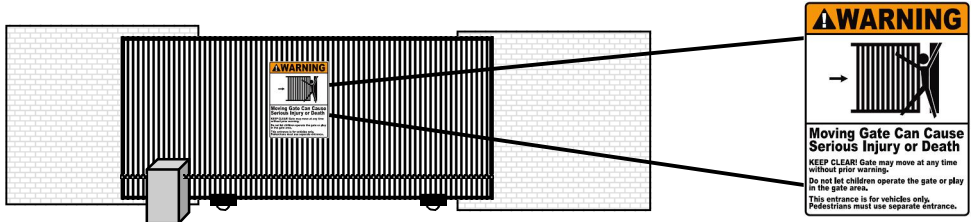

INSTALLATION PRECAUTIONS:

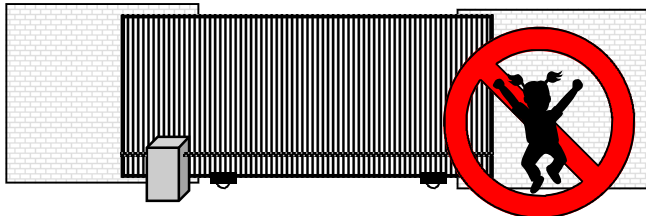

DO NOT allow children to play near, on or with the gate, gate operator, or any of its controls.

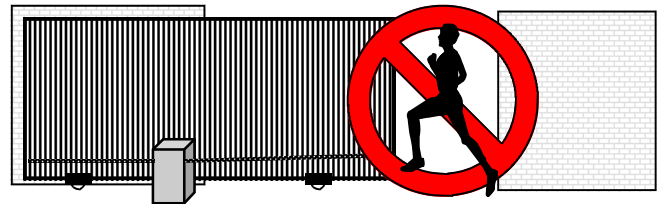

DO NOT allow pedestrian use of the vehicular gate. No one should cross the path of a moving gate!

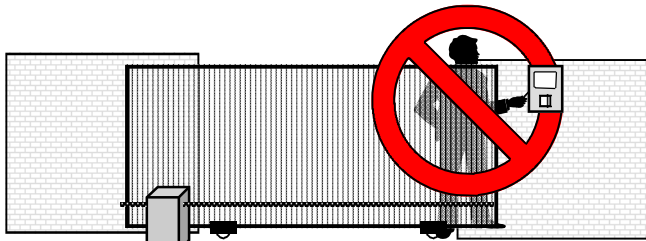

DO NOT mount operating devices accessible through the gate or in between the gate and wall.

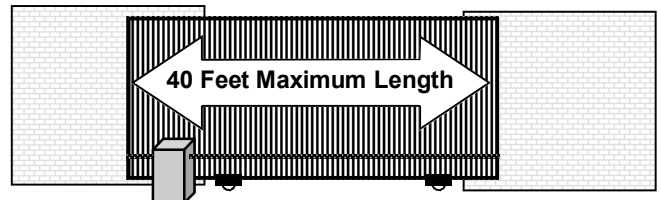

DO NOT mount the gate operator to a gate longer than 40 feet. Maximum gate length = 40 feet.

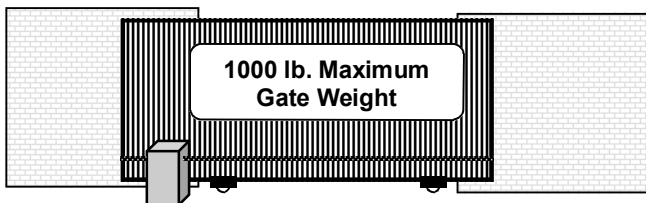

DO NOT mount the gate operator to a gate heavier than 1000 pounds. Maximum gate weight = 1000 lbs.

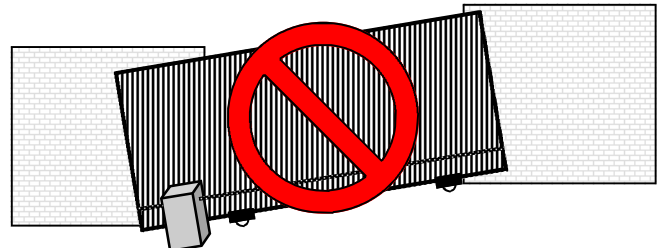

DO NOT mount the gate operator on uphill or downhill applications. Do not allow the gate to free roll.

Read and follow all U.L. and Safety Standards before installing any access device. Please refer to this manual and qualified personnel for assistance. DO NOT install this device unless all entrapment and pinch points are eliminated.

GATE OPERATOR INSTALLATION



WARNING: Install over-travel stops at both ends of the gate rail or track for all types of installations to help prevent the gate from derailing.

PREINSTALLATION GUIDELINES:

Before starting any installation, consider the following guidelines:

- Install the gate system and gate in accordance with ASTM F220-02: Standard Specification for Automated Vehicular Gate Construction. Install the gate system and gate in accordance with UL325 standards.
- Be sure the gate is properly installed and moves freely. Repair or replace worn or damaged gate hardware before installing the gate operator.
- Install over-travel stops at both ends of the gate rail or track for all types of installations to help prevent the gate from derailing.
- Add safety devices such as warning signs, photo eyes, and reverse edges to help prevent injuries or death. Reduce all pinch points and protect all entrapment positions.
- If pedestrian traffic will be present, provide a separate pedestrian walk gate clear from the path of the automatic gate.
- Loops and loop detectors are required to help prevent the gate from closing on vehicles. Loops do not protect pedestrian traffic.
- Select the proper gate operator for the installation. Consider the usage, capacity, gate size, gate weight, and needed features and safety accessories.

GATE OPERATOR LOCATION:

Select a location for the gate operator to be installed prior to pouring the concrete pad. There are two ways to mount a slide gate operator: the traditional front mount, or the rear mount method. Both methods have their advantages and will reliably open the gate.

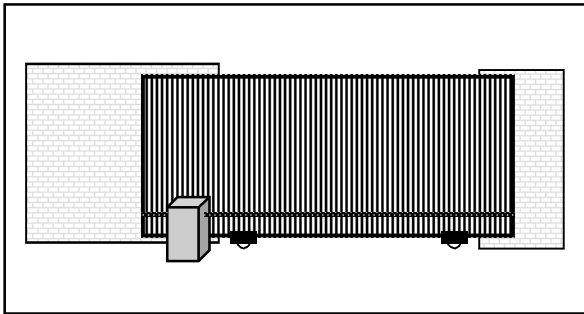

FRONT MOUNT METHOD:

The front mount method places the operator up front near the flow of traffic and uses a single chain across the length of the gate. The advantages and disadvantages include:

Advantages:

- Less chain is required for the application saving money and time.
- Does not require the use of an additional idler sprocket saving money and time.
- Less room is needed for the application and allowing the operator to be more accessible for service.

Disadvantages:

- The operator is up front near the flow of traffic allowing for a vehicle to damage the operator more easily.
- The chain runs across the length of the gate allowing visitors to see and possibly tamper with it.

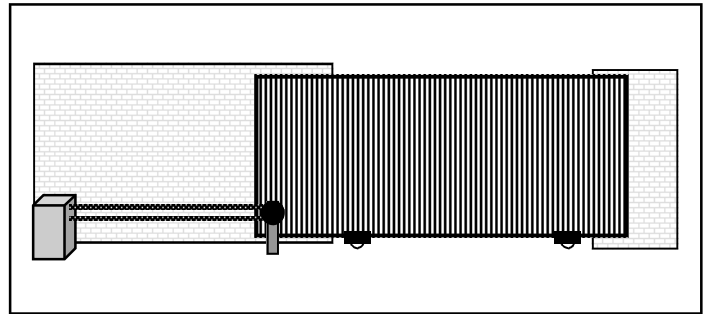

REAR MOUNT METHOD:

A rear mount installation places the operator at the back of the gate and uses a double chain with an additional idler sprocket. The advantages and disadvantages include:

Advantages:

- The chain is attached to the rear of the gate and is not visible when the gate is closed.
- The operator is in the back away from the flow of traffic for added safety.
- The operator is in the back allowing more room for tight parking conditions.

Disadvantages:

- Twice as much chain is required for this type of application = added expense.
- The application requires the use of an additional idler sprocket = added expense.

GATE OPERATOR INSTALLATION

! WARNING: Install over-travel stops at both ends of the gate rail or track for all types of installations to help prevent the gate from derailing.

CONCRETE PAD SIZE & LOCATION:

The DSL2000 vehicular gate operator is designed to be mounted on a concrete pad. Select a location for the gate operator to be installed. For pad location and size:

1. Determine the location for the operator to be installed. (Front Mount v. Rear Mount)
2. Follow all local building codes to determine the required depth of the concrete pad. The average concrete pad should be 24+wide x 24+long x 24+deep.
3. Extend the pad 4+above ground and 24+below ground.
4. When the exact location of the operator can be predetermined, all conduits may be located in the concrete pad terminating directly under the operator. Extend each conduit a minimum of 1+above the level of the concrete pad. See the Conduit Location diagram below. It is suggested to install a minimum of four (4) conduits: (1) High Voltage Conduit, (1) Low Voltage Conduit, (1) Loop Lead Wire Conduit, (1) Accessory Conduit.
5. When the exact location of the operator can not be predetermined, bring all conduits up to one side and terminate in a Bell Box. Make connections to the operator using water-tight flex conduit.
6. Form the concrete pad as shown and pour concrete. Allow the concrete to cure for 48 hours before removing the forms and mounting the operator.
7. Do not place mounting bolts in the concrete while pouring. Bolts may drift in wet concrete making the operator location inaccurate.
8. NOTE: The path of the gate and gate track must be installed on concrete. The average gate track concrete should be a minimum of 10+wide x 12+deep the entire length of the gate track and travel. Failure to place the gate track on concrete can result in track movement and cause gate failure or derailment.

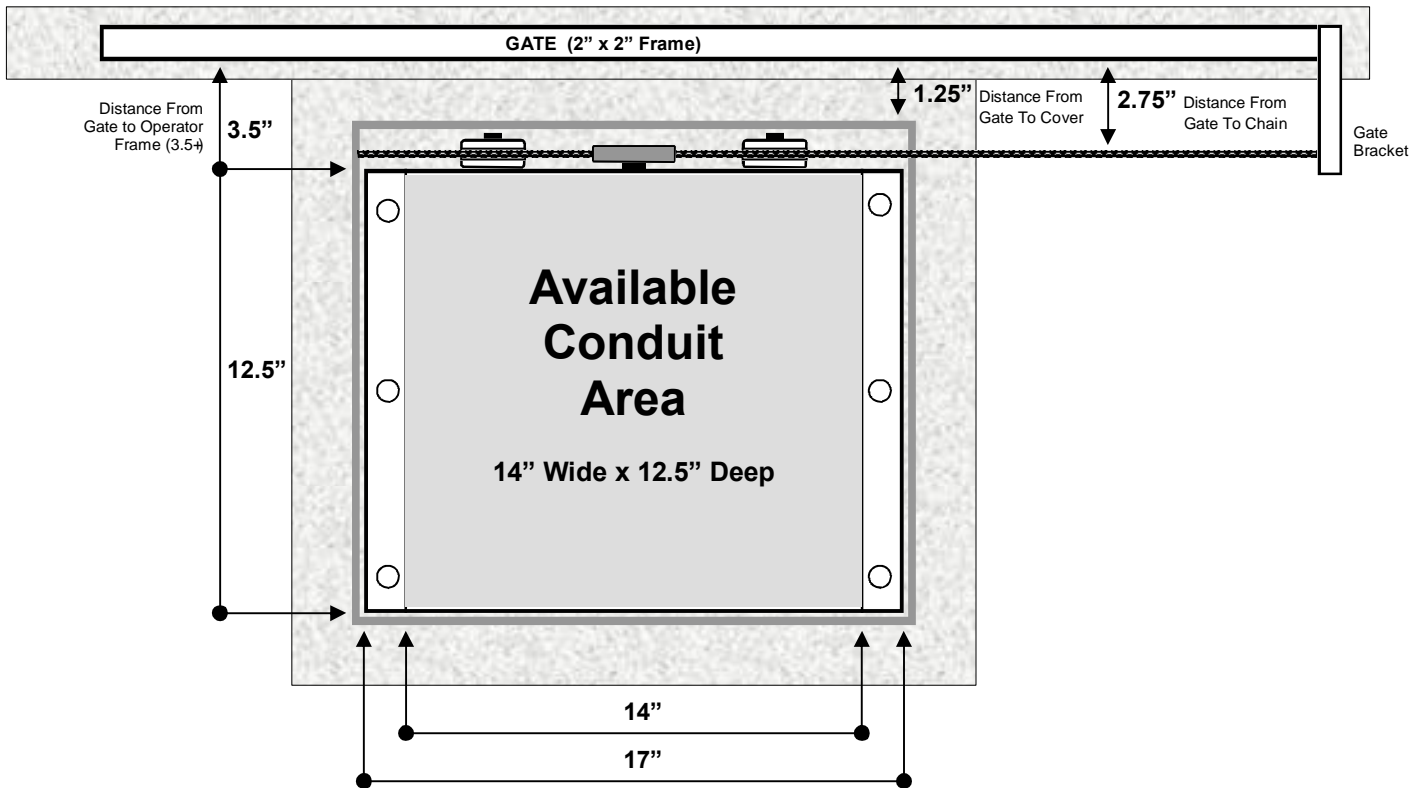
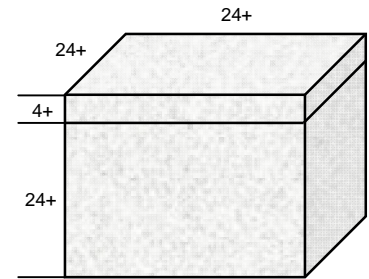

GATE OPERATOR INSTALLATION

GATE OPERATOR BOLT DOWN

To align the operator to the gate and bolt it down:

1. Remove the gate operator cover and place the operator on the concrete pad. Position the operator with a distance of 3.5+ from the gate to the back frame of the operator. **IMPORTANT:** Make sure the gate and operator are parallel and level with each other.
2. Mark the mounting holes and remove the operator. Drill the mounting holes to the required depth and diameter for the sleeve anchors being used. It is recommended to use 3/8"x 4" sleeve anchors. The use of sleeve anchors allows greater flexibility and makes the installation and alignment much easier.
3. Clean the mounting holes and install the sleeves. Position the operator over the anchors. Recheck to make sure the gate and operator are parallel and level with each other. Tighten the anchor bolts to securely hold the operator.

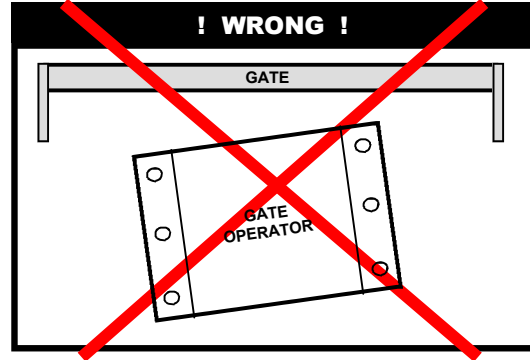
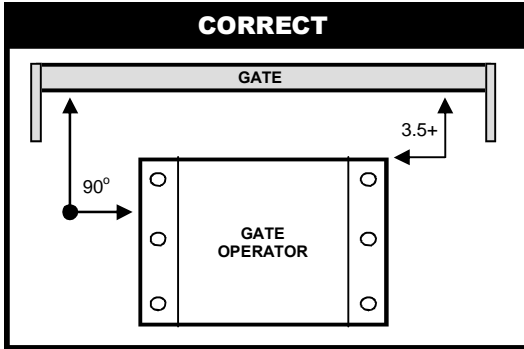

CHAIN CONNECTION - FRONT MOUNT

Once the gate operator is securely bolted down, the chain may be attached. To attach the chain for a front mounted system:

1. Make sure the chain will be in a straight line and same height as the lower idler sprockets.
2. Weld the chain brackets to the end of each side of the gate and level with the lower idler sprockets. (Approximately 11+)
3. Route the chain through the operator, over the first lower chain idler, under the chain sprocket, and over the second lower idler.
4. Connect the chain bolts to each end of the chain using the supplied master links. Connect the chain bolts to the chain brackets. Adjustments to the chain length should be made now.
5. Tighten the chain using the chain bolts so the chain does not sag more than one (1) inch per 10 feet of travel. Do not over tighten!

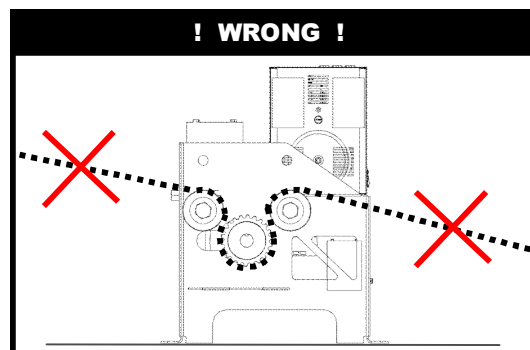
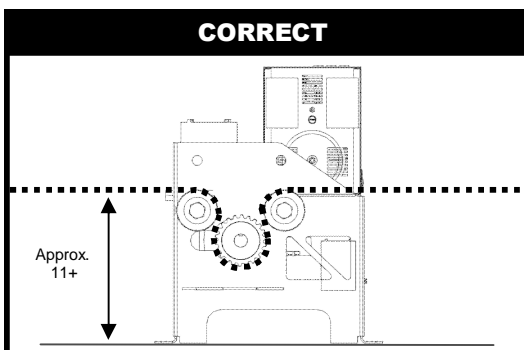
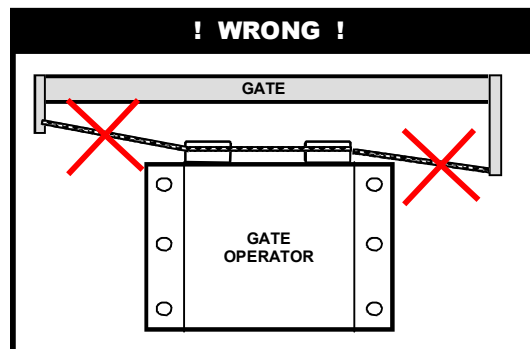
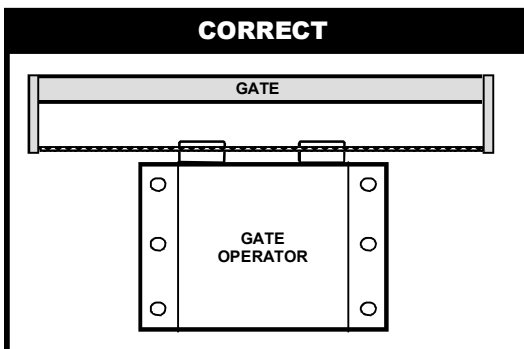

GATE OPERATOR INSTALLATION

CHAIN CONNECTION - REAR MOUNT

Rear mount operators require the use of an endless idler assembly and twice as much chain. Approximately 1 foot of added opening space is needed. Once the gate operator is securely bolted down, the chain may be installed for a rear mount system.

1. Adjust the chain idler sprocket inside the gate operator for a rear mount application. Remove the lower idler on the unused side and move it to the upper idler hole on the chain side of the operator. Both chain idlers should be above/below each other.
2. Increase the cover chain slot on the chain side of the operator. (Side toward the gate opening)
3. Close the gate and mount an endless idler assembly near the back of the gate. The chain must extend beyond the back of the gate. **IMPORTANT:** Only use an endless idler assembly with a safety guard to prevent pinch and entrapment points.
4. Adjust the height of the endless idler sprocket so the chain from the lower chain idler is level with the bottom of the endless idler. (Approximately 11") Make sure the chain will be in a straight line and same height as the lower idler sprocket.
5. Weld the bottom chain bracket to the end of the gate and level with the top of the endless idler sprocket. (Height depends upon the size of the endless idler sprocket)
6. Weld the top chain brackets to the end of the gate and level with the top of the upper idler sprocket. (Approximately 15")
7. Route the chain through the operator, over the upper chain idler, around and under the chain sprocket, and over the lower idler.
8. Route the lower chain under and around the endless idler assembly.
9. Connect the chain bolts to each end of the chain using the supplied master links. Connect the chain bolts to the chain brackets. Adjustments to the chain length should be made now.
10. Tighten the chain using the chain bolts so the chain does not sag more than one (1) inch per 10 feet of travel. Do not over tighten!

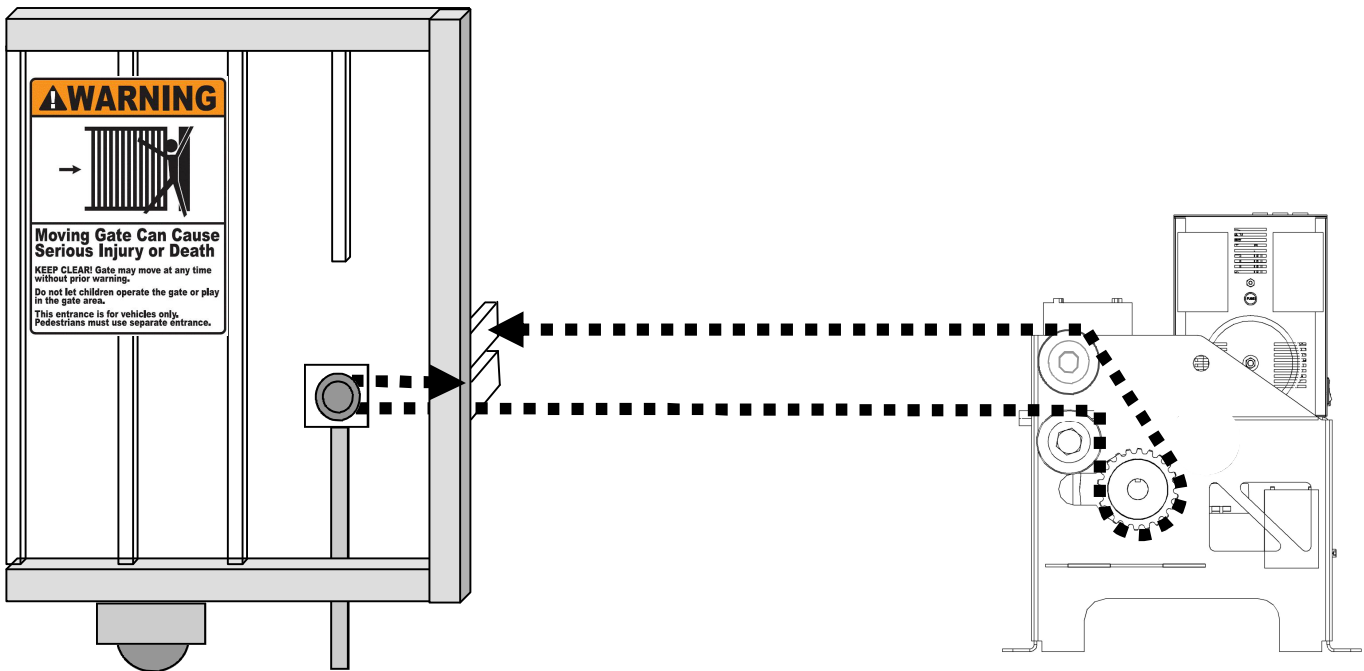

WARNING: DO NOT INSTALL this product unless all safety standards are followed and all entrapment and pinch points have been eliminated.

GATE OPERATOR INSTALLATION

LIMIT SWITCH SETUP:

The gate operator uses a limit switch assembly to adjust the distance of travel. These adjustments should be made before power is supplied to the operator. To adjust the distance of travel using the limits:

1. Turn power OFF! Use the power switch on the side to assure AC and Battery power are both OFF.
2. Manually move the gate fully to the right. Push the limit guide plate down and roll the top limit nut until it activates the top limit switch. The switch will click when activated.
3. Manually move the gate to the left. Push the limit guide plate down and roll the bottom limit nut until it activates the bottom limit switch. The switch will click when activated.
4. Release the limit guide plate and make sure it is engaged in the slots of each limit nut.
5. Readjust the limit nuts as necessary to fine tune the full-open and full-closed positions.

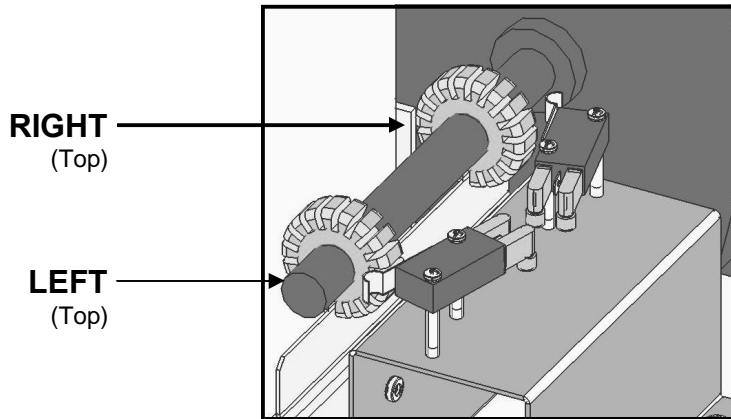

GATE OPERATOR DIRECTION:

The gate operator uses a DIP switch setting to determine the open and close direction. To set the Open/Close direction:

1. Turn power OFF! Use the power switch on the side to assure AC and Battery power are both OFF.
2. Standing inside the gate looking at the gate operator, determine if the gate opens to the LEFT or RIGHT.
3. If the gate opens to the LEFT, move DIP SWITCH 6 to the Left.
4. If the gate opens to the RIGHT, move DIP SWITCH 6 to the Right.

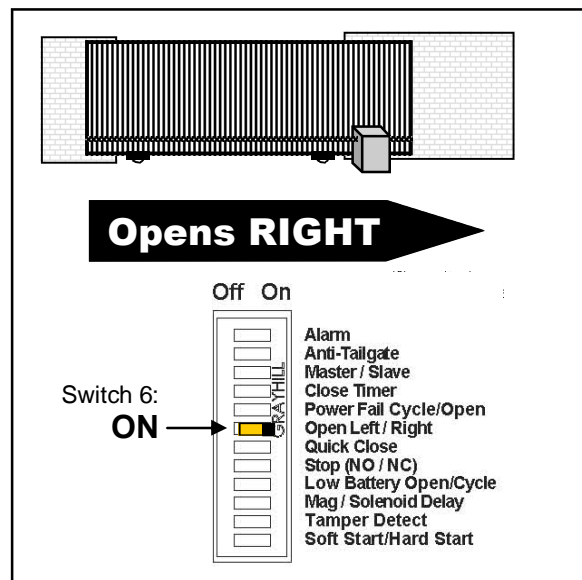
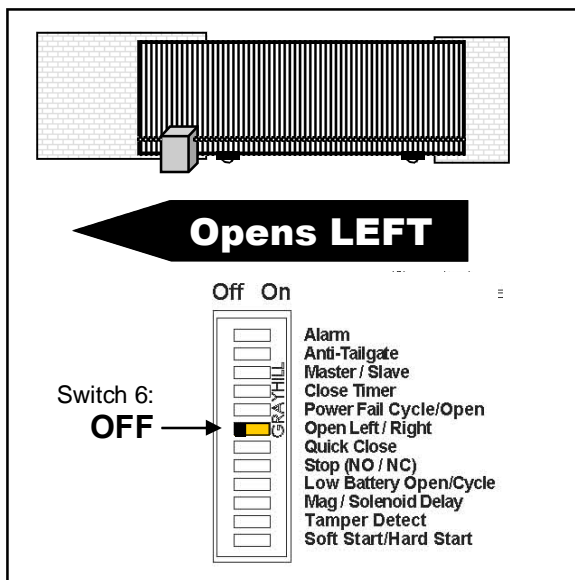

ELECTRICAL INSTALLATION

POWER SWITCH LOCATION:

The gate operator uses a built-in power switch to control power to the operator and controller. This switch should be turned OFF during installation and service. Failure to use this switch can result in unexpected gate movement. Please note:

1. The switch is located on the LEFT side of the control box.
2. DOWN position = OFF. UP position = ON.
3. This switch must be used to turn OFF AC and battery power. Only disconnecting AC power still allows battery power to the operator, controller, and accessories.
4. Turn OFF until the installation is complete.

AC POWER GUIDELINES:

Under normal conditions, the gate operator will use a single phase AC power line to operate the gate, charge the batteries, and power gate accessories. Use the following guidelines when installing the AC power:

1. Check the local wiring codes in all cases and follow all local building codes. Wiring and hookup should be performed by a qualified electrician/installer only.
2. AC power should be supplied from a circuit breaker panel and must have its own dedicated circuit breaker. This supply must include a green ground conductor.
3. Only use U.L. approved 14 AWG or larger 600 Volt Insulated Wire. Use the following chart to determine the AC wire size. This information is for suggested use only - Check your local codes before installation.

Wire Size:	14 Gauge	12 Gauge	10 Gauge	8 Gauge	4 Gauge
Distance:	250 Feet	400 Feet	650 Feet	1000 Feet	2000 Feet

4. Properly ground the gate operator to minimize or prevent damage from power surges and/or lightning. Use a grounding rod if necessary. A surge suppresser is recommended for additional protection.

AC POWER CONNECTION:

To connect AC power to the gate operator:

1. Turn the circuit breaker for the AC gate operator power OFF before connecting the AC input wires.
2. Turn the Power Switch OFF located on the left side of the controller before connecting the AC input wires.
3. Connect the AC input wires to the AC terminal located on the bottom/center of the control box. See diagram below.
4. Batteries must be installed after the AC power is on. See Battery Power Connection.

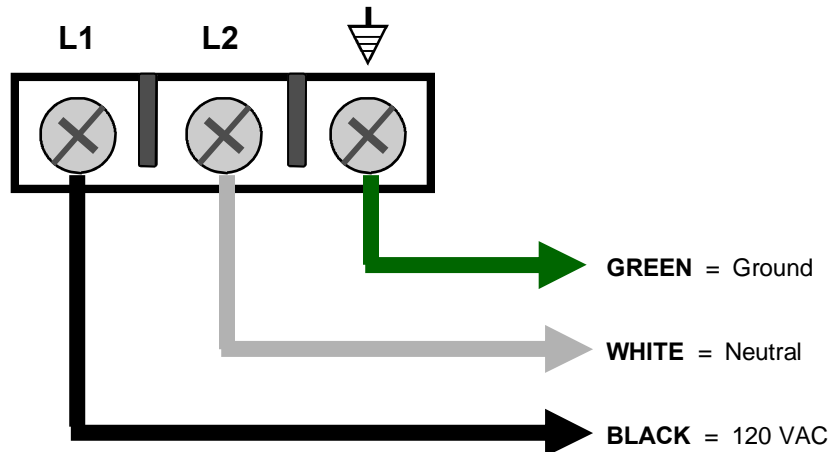

ELECTRICAL INSTALLATION

BATTERY POWER CONNECTION:

If AC power is connected, the system does not need the batteries to function. However, the batteries must be connected for the Power Fail Battery Backup features to operate. When AC power is active, the batteries will charge until fully charged. Once the batteries have fully charged, the system will stop charging. Charging is automatic when AC power is available. The system should be prewired with the batteries. If not, to connect batteries to the system:

1. Connect the RED wire from the Battery + Terminal to the positive terminal of the first battery.
2. Connect the BLACK wire from the Battery - Terminal to the negative terminal of the second battery.
3. Connect a jumper between the remaining terminals of each battery.

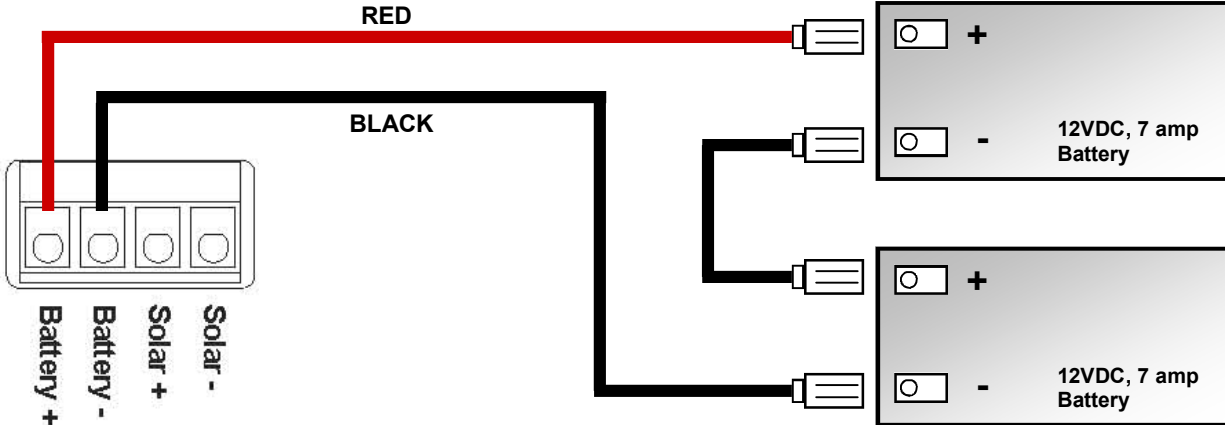

⚠ Batteries should be tested regularly for proper battery backup operation. Batteries should be replaced each year or as needed.

ACCESSORY POWER:

Two plug-in power plugs are located on the back of the controller. These plugs are for low voltage accessories and are separately fused. Low voltage, low current draw transformers may be plugged into these outlets for accessory power. **DO NOT USE THESE POWER OUTLETS FOR INSTALLATION OR SERVICE TOOLS.** Each plug supplies 110 VAC when AC power is active to the gate operator. If AC is not available, the power plugs will not supply power. Accessories requiring power during battery backup modes should use the 24 VDC located on the controller terminals.

Additional accessory power may be found on the controller terminals. The controller terminals supply 24 VDC for accessories. This power is available during AC and battery power modes. When AC power is active, accessories will be supplied 24 VDC without a power draw on the batteries. When the battery backup mode is active, accessories will be supplied 24 VDC from the batteries. If the battery power mode is used frequently, consider the current draw of the accessories. The lower the current draw, the longer the battery power supply will last. Additional 24 VDC for accessories may be found on the Radio Terminal, Edge/Photo Terminal, and External Loop Terminal. A connection between 24V DC+ and Common will supply power.

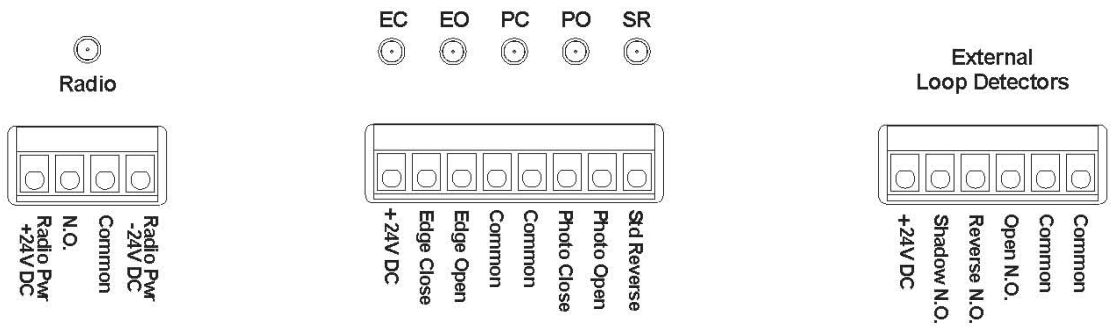

ELECTRICAL INSTALLATION

MASTER/SLAVE CONNECTION:

The gate operator uses RS422 connectors to wire a Master and Slave operator together. The RS422 connectors allow for a stronger more complete signal between the two operators. **All external devices and inputs must be wired directly to the Master operator.** To connect two operators together:

1. Determine which operator is the Master and which operator is the slave. All external devices such as loop detectors and safety devices must be wired directly to the Master unit.
2. Turn Slave Operator DIP Switch 3 to ON = SLAVE
3. Turn Master Operator DIP Switch 3 to OFF = MASTER
4. In a separate conduit, run a 6-conductor cable between the Master operator and the Slave operator. (Recommended Wire: Outdoor Rated CAT 5 or CAT 7 Cable)
5. Using RS422 connectors, color connect each wire.
 - MASTER ORANGE WHITE to SLAVE ORANGE WHITE (Pin 1 to Pin 6)
 - MASTER ORANGE to SLAVE ORANGE (Pin 2 to Pin 3)
 - MASTER GREEN WHITE to SLAVE GREEN WHITE (Pin 3 to Pin 2)
 - MASTER GREEN to SLAVE GREEN (Pin 6 to Pin 1)
 - MASTER BROWN WHITE to SLAVE BROWN WHITE (Pin 5 to Pin 5)

IMPORT NOTE:
All external safety and auxiliary devices must be wired directly to the Master operator.

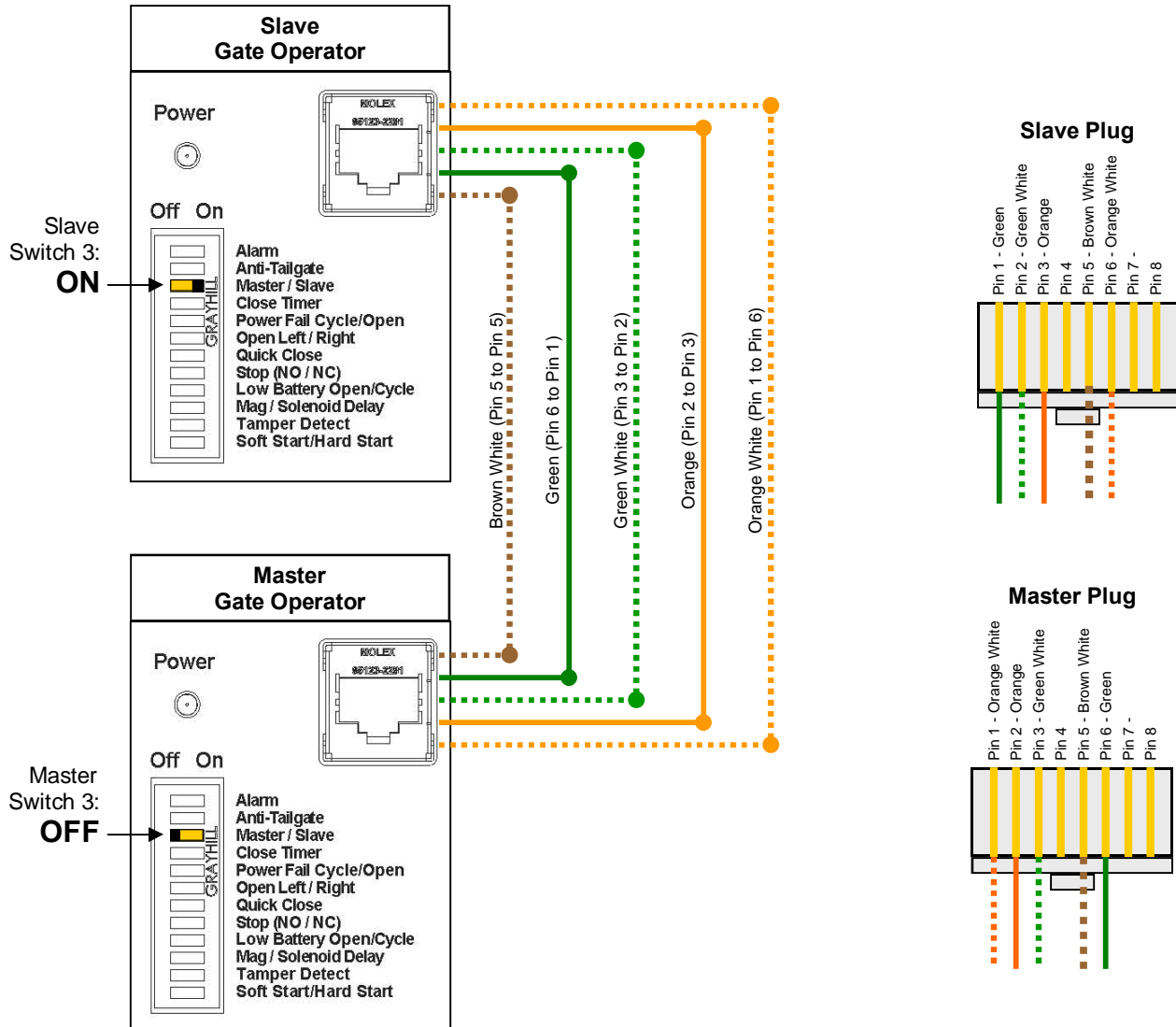

GATE OPERATOR ADJUSTMENTS

REVERSE SENSITIVITY ADJUSTMENT:

The gate operator is equipped with an inherent (Type A) entrapment sensing system. The sensor detects obstructions in both the open and close path of the gate. There is an OPEN SENSITIVITY Adjustment and a CLOSE SENSITIVITY Adjustment. To adjust the sensitivity:

1. Activate the gate to open.
2. While the gate is running open, slowly rotate the OPEN SENSITIVITY adjustment clockwise to INCREASE the sensitivity until the gate stops in mid-travel.
3. Gently rotate the OPEN SENSITIVITY adjustment counter-clockwise 1/8 turn to DECREASE the sensitivity.
4. Activate the gate to close.
5. While the gate is running closed, slowly rotate the CLOSE SENSITIVITY adjustment clockwise to INCREASE the sensitivity until the gate stops in mid-travel.
6. Gently rotate the CLOSE SENSITIVITY adjustment counter-clockwise 1/8 turn to DECREASE the sensitivity.
7. Operate the gate a few times to be sure it fully cycles without stopping.
8. Place an immobile object in the open path of the gate to stop the gate while in travel. The gate should stop and enter a Soft Shutdown upon striking the object.
9. Place an immobile object in the closed path of the gate to stop the gate while in travel. The gate should stop and enter a Soft Shutdown upon striking the object.
10. Repeat steps 2 - 6 until the correct sensitivity adjustment is found.

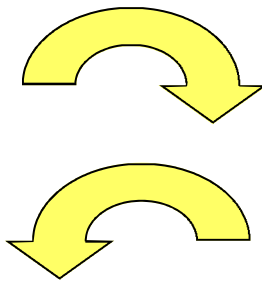

Clockwise Turn:
INCREASE Sensitivity
 (Reverse the gate more easily)

Counter-Clockwise Turn:
DECREASE Sensitivity
 (Reverse the gate less easily)

CAUTION:

Gently rotate each adjustment. Turning the adjustment POT too hard will break the adjustment.



For the Reverse Sensor to function correctly, the gate must be properly installed and work freely in both directions. Repair or replace worn hardware. DO NOT use sensitivity to compensate for a gate in need of service.

REVERSE SENSITIVITY SHUTDOWN:

Upon a first obstruction, the reverse sensor should:

1. Stop the gate and reverse it approximately two (2) inches.
2. Disable the Timer To Close Feature until the gate operator receives a new command = Soft Shutdown.
3. Any standard input can reactivate the gate and return it to normal operation.

Upon a second consecutive obstruction before the gate reaches either limit, the reverse sensor should:

1. Stop the gate.
2. Disable the gate operator = Hard Shut Down.
3. Sound the audio alarm for five (5) minutes or until the operator has been reset.
4. Only resetting the operator will reactivate the gate and return it to normal operation.
5. To reset the operator in a Hard Shut Down situation: Press the reset button on the left side of the controller or turn the power switch OFF and back ON.



WARNING: DO NOT INSTALL this product unless all safety standards are followed and all entrapment and pinch points have been eliminated.

GATE OPERATOR ADJUSTMENTS

CLOSE TIME DELAY ADJUSTMENT:

The gate operator is equipped with a built-in automatic timer to close feature. This feature should be set to the OFF position until proper safety and reverse devices have been installed. **CAUTION:** Turning on the Close Time Delay without proper safety and reverse devices can cause serious injury, death, and property damage. The Close Time Delay can be set to from 1 to 90 seconds. When active, the Close Time Delay will hold the gate open until the internal timer has timed out and then allows the gate to close. To turn OFF/ON and adjust the Close Time Delay:

1. To turn OFF the Close Time Delay, move DIP SWITCH 4 to the Left.
2. To turn ON the Close Time Delay, move DIP SWITCH 4 to the Right.
3. Turn power Off and back On to reset DIP Switch settings.
4. Rotate the TIME DELAY adjustment clockwise to INCREASE the delay.
5. Rotate the TIME DELAY adjustment counter-clockwise to DECREASE the delay.

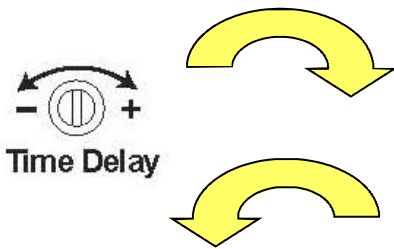

Clockwise Turn:
INCREASE Time Delay
 (Holds gate open longer time)

Counter-Clockwise Turn:
DECREASE Time Delay
 (Holds gate open shorter time)

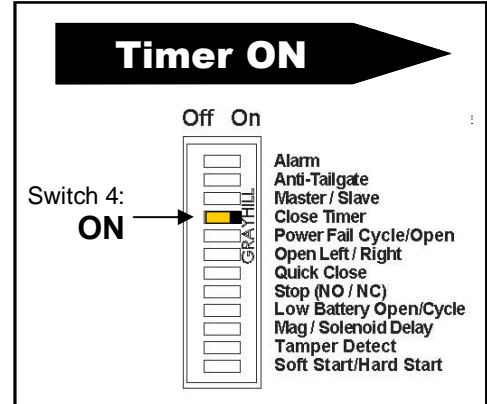

CAUTION:

Gently rotate each adjustment. Turning the adjustment POT too hard will break the adjustment.

DIP SWITCH SETTINGS

The DIP Switches located on the top right face of the controller are used to set several different functions. This list gives a brief description. The factory setting is in bold print. Please review each individual section in this manual for more detail.

Switch	Function	Description
1	Alarm	OFF: Sounds the built-in alarm in shutdown applications only. ON: Beeps while gate is moving. Sounds the alarm in shutdown applications.
2	Anti-Tailgate	OFF: Gate opens and closes normal. ON: Uses loops to control vehicles individually.
3	Master/Slave	OFF: Operator is set as a Master (Primary). ON: Operator is set as a Slave (Secondary).
4	Close Timer	OFF: Time Delay Close feature is inactive. Command to open, command to close. ON: Time Delay Close feature is active. Gate opens, times out, closes.
5	Power Fail Cycle / Open	OFF: During power failure, gate will cycle using BBU until batteries are too low to function. ON: During power failure, gate will open and remain open until AC power is restored.
6	Open Left/Right	OFF: Opens the gate Left. (Standing inside looking out at operator) ON: Opens the gate Right. (Standing inside looking out at operator)
7	Quick Close	OFF: Gate opens and closes normal. ON: Gate opens until loops are cleared. Then close gate even if gate did not reach full open position.
8	Stop (NC / NO)	OFF: Allows a NC Stop Switch to be used. This setting default is OFF until a Stop Switch is installed. ON: Allows a NO Stop Switch to be used. Stop Switch must be installed for this setting to be ON.
9	Battery Cycle	OFF: Cycles gate until batteries are too low and stops. Switch 5 must be OFF. ON: Cycles gate until batteries are too low and then opens gate. Switch 5 must be OFF.
10	Mag / Solenoid Delay	OFF: No delay - activates gate immediately ON: Delays 2 seconds before activating gate. Slave opens first followed by Master. Master closes first.
11	Tamper Detect	OFF: Gate opens and closes normal. ON: When closed, if gate is forced off limit, alarm sounds, motor stops open movement and closes gate.
12	Hard Start	OFF: Gate opens and closes normal. ON: Gate starts with 40% motor power for more starting torque. Normal start = 5% motor power.

ACCESSORY CONNECTIONS

ACCESSORY WIRE OVERVIEW:

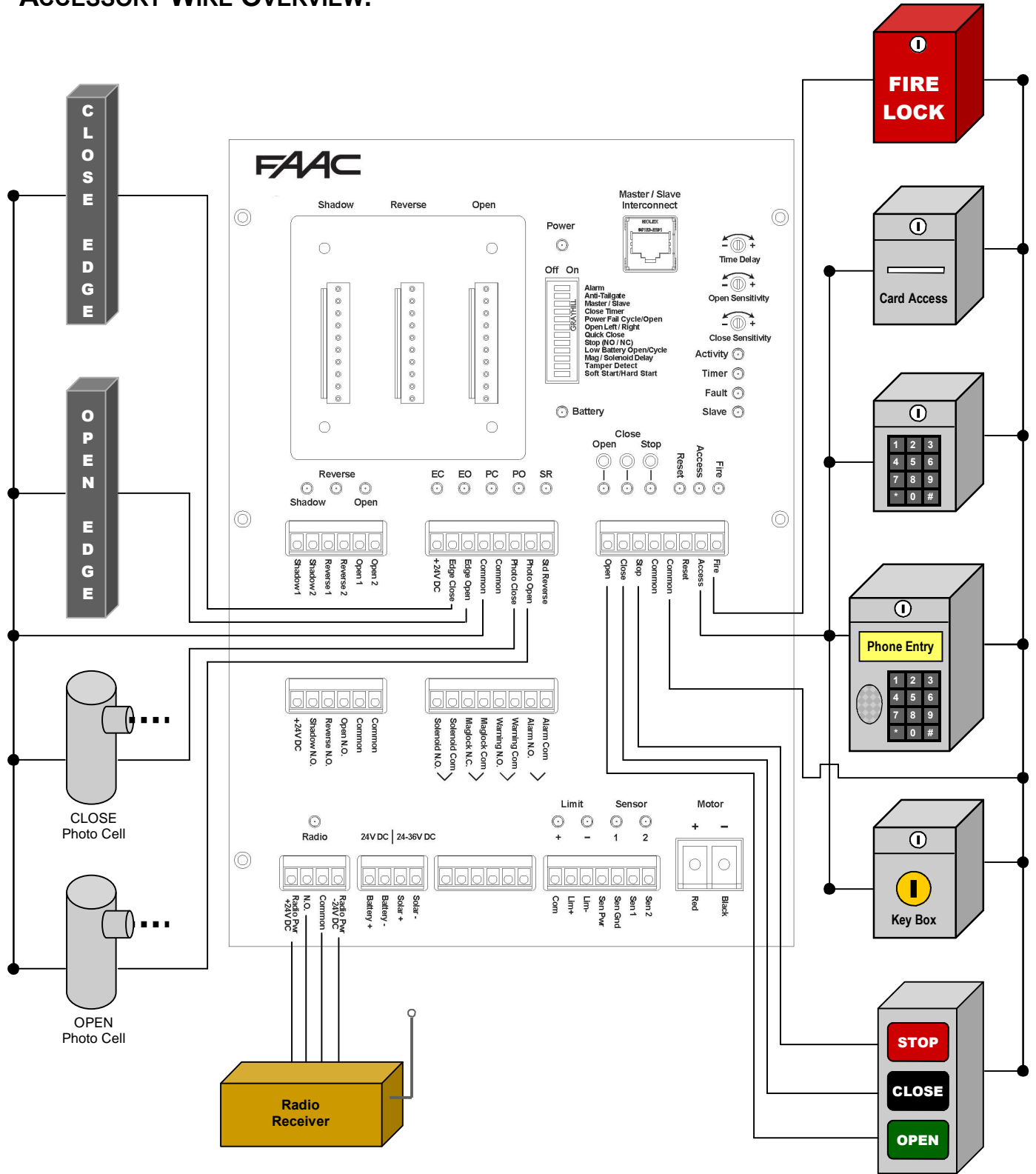

WARNING: DO NOT INSTALL this product unless all safety standards are followed and all entrapment and pinch points have been eliminated.

ACCESSORY CONNECTIONS

EDGE SENSOR CONNECTIONS:

The gate operator has a Close Edge Terminal and an Open Edge Terminal for added control of the Sensing Edge functions. The following chart describes the functions for a Close Edge Sensor and an Open Edge Sensor:

Close Edge Input:

1. Input is only active during close cycle.
2. An input during the close cycle will stop and reverse the gate to the full open position.
3. If an Open Edge Input is active before reaching the full open position, the gate will stop and enter a soft shutdown.
4. If the gate reaches the full open position and the Time Delay Close is ON, the gate will time out and close.
5. If the gate reaches the full open position and the time Delay Close is OFF, the gate will remain open until a close input is received.
6. If a second Close Edge Input is received while closing, the gate will stop and enter a soft shutdown.

Open Edge Input:

1. Input is only active during open cycle.
2. An input during open cycle will stop and reverse the gate to the full closed position and enter a soft shutdown.
3. NOTE: If the gate was initially activated by a time clock with a contact closure across the Access Input, this input will be ignored until another input (Open Loop, Reverse Loop, etc.) is received.
4. If a Close Edge input is active before reaching the full closed position, the gate will stop and enter a soft shutdown.

To connect a Sensing Edge:

1. Refer to the External Entrapment Prevention-section of this manual for guidelines and placement.
2. Connect Close Edge Sensors to EDGE CLOSE and COMMON.
3. Connect Open Edge Sensors to EDGE OPEN and COMMON.

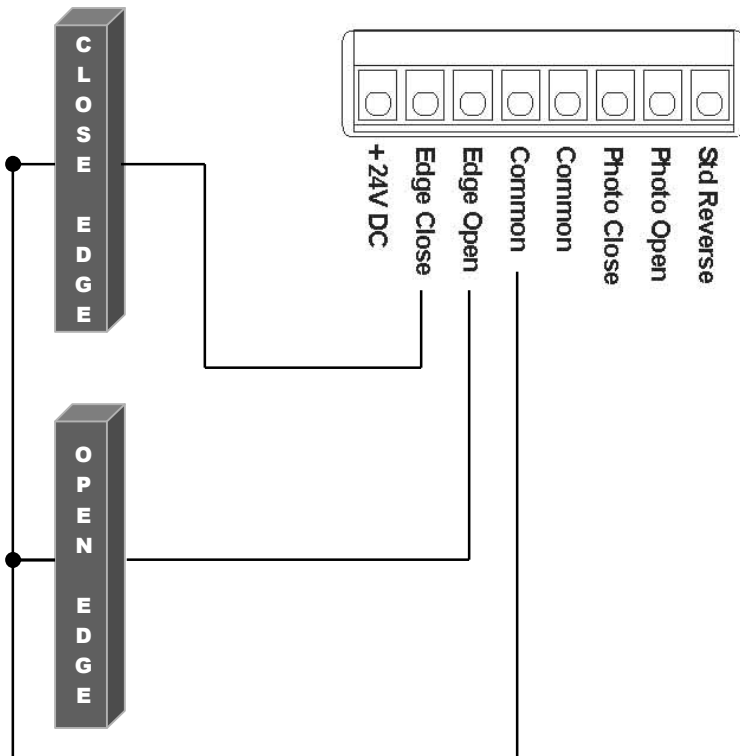

Edge Sensor Notes:

1. One or more contact sensors shall be located where the risk of entrapment or obstruction exists, such the leading edge, trailing edge, and posts mounted inside and outside of the vehicular slide gate and motor.
2. Hardwired contact sensors shall be located and its wiring arranged so the communication between the sensor and the gate operator is not subject to any mechanical damage.
3. Wireless contact sensors such as ones that transmit radio frequency (RF) signals to the gate operator for entrapment prevention functions shall be located where the transmission of the signals are not obstructed or impeded by building structures, landscaping or similar obstructions. All wireless contact sensors shall function under the intended end-use conditions.
4. Wireless contact sensors should be checked on a regular basis. Batteries should be replaced on a

⚠ WARNING: DO NOT INSTALL this product unless all safety standards are followed and all entrapment and pinch points have been eliminated.

ACCESSORY CONNECTIONS

PHOTO SENSOR CONNECTIONS:

The gate operator has a Photo Close Terminal and an Photo Open Terminal for added control of the Photo Sensor functions. The following chart describes the functions for a Photo Close Sensor and a Photo Open Sensor:

Photo Close Input:

1. Input is only active during close cycle.
2. An input during the close cycle will stop the gate.
3. The gate will remain stopped until the input is cleared.
4. When the Photo Close is cleared, the gate will continue to close.

Photo Open Input:

1. Input is only active during open cycle.
2. An input during open cycle will stop the gate.
3. The gate will remain stopped until the input is cleared.
4. When the Photo Open is cleared, the gate will continue to open.

To connect a Photo Sensor:

1. Refer to the External Entrapment Prevention section of this manual for guidelines and placement.
2. Connect the Photo Close Sensor to PHOTO CLOSE and COMMON.
3. Connect the Photo Open Sensor to PHOTO OPEN and COMMON.
4. For Photo Sensors that use 24VDC power, connect power to +24VDC and COMMON.

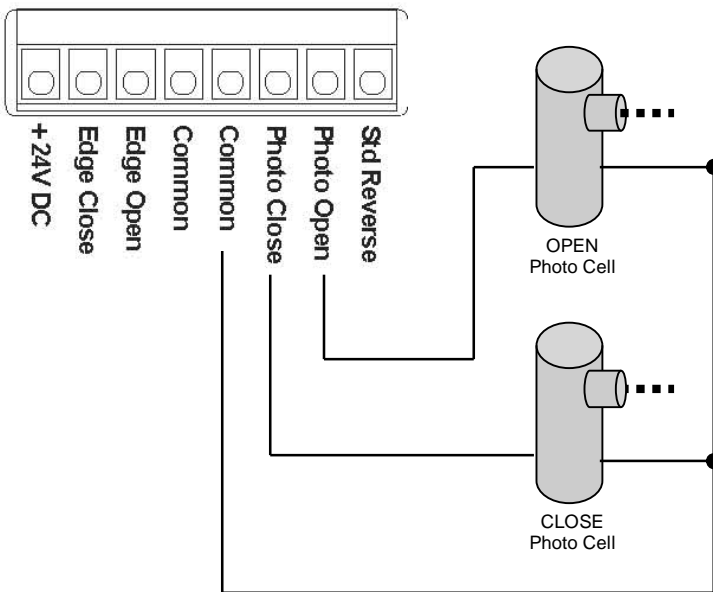

Photo Sensor Notes:

1. Use care to reduce the risk of nuisance tripping, such as when a vehicle trips the sensor while the gate is still moving.
2. One or more non-contact sensors shall be located where a risk of entrapment or obstruction exists, such as the perimeter reachable by a moving gate or barrier. Use caution when installing non-contact sensors since some devices only cover a select area. For example, a photo beam will not cover the full height of a gate/fence area. Refer to the diagram below.
3. Use only UL325 compliant devices and follow all installation guidelines set forth by the manufacturer.

! WARNING: DO NOT INSTALL this product unless all safety standards are followed and all entrapment and pinch points have been eliminated.

ACCESSORY CONNECTIONS

STANDARD REVERSE CONNECTIONS:

The Standard Reverse Terminal is for applications when an external device may be used as a standard reverse. For example: Photo Sensors connected to this terminal will operate the same as a Reverse Loop. This connection should not be used for Safety Reverse Devices. Use Edge and Photo inputs for proper Safety connections.

Standard Reverse Input:

1. Input is inactive when gate is closed or in the open cycle.
2. When gate is open and Time Delay Close is ON, an input will reset the Time Delay Close.
3. When gate is open and Time Delay Close is OFF, an input will prevent the gate from closing.
4. When gate is closing, an input will reverse the gate.

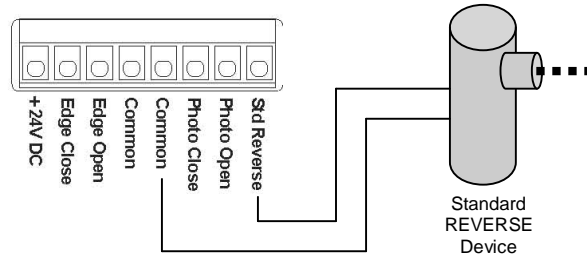

Connecting Standard Reverse Devices:

1. Connect to STD REVERSE and COMMON
2. For Devices that use 24VDC power, connect power to +24VDC and COMMON

OPEN, CLOSE, STOP CONNECTIONS:

The gate operator may use an external Open, Close, Stop (3-Button) to control the gate. The controller has built-in button controls above each terminal for setup and testing.

Open, Close, Stop Input:

1. OPEN: Allows external input to OPEN gate.
2. CLOSE: Allows external input to CLOSE gate.
3. STOP: Allows external input to STOP gate.

Connecting Standard Reverse Devices:

1. Connect Open Button to OPEN and COMMON.
2. Connect Close Button to CLOSE and COMMON.
3. Connect Stop Button to STOP and COMMON.

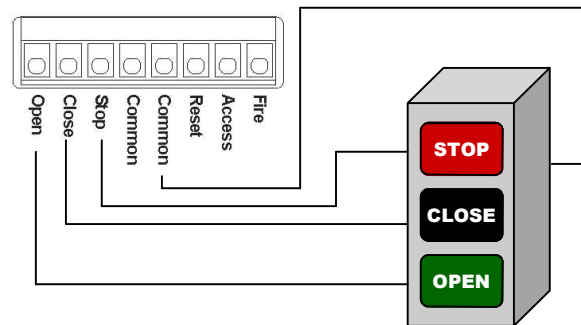

EXTERNAL RESET CONNECTION:

An external Reset Button may be connected to the Reset Terminal and used to reset the operator during Hard Shutdown situations. During a Hard Shutdown, the operator can only be reset through the reset input or reset button on the left side of the controller. The Reset Input can also be used during installation to reset the operator settings.

Reset Input:

1. Allows external input to reset gate operator during a Hard Shutdown.
2. Allows external input to reset operator settings during installation.

Connecting External Reset Devices:

1. Connect Reset Button to RESET and COMMON.

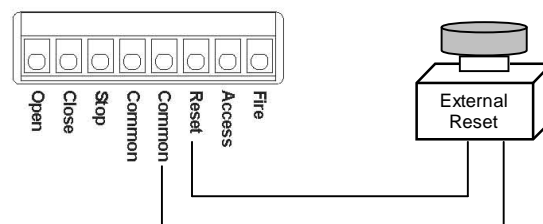

ACCESSORY CONNECTIONS

ACCESS CONTROL CONNECTION:

Access Control Devices such as Telephone Entry Systems, Digital Locks and Card Readers may be connected to the Access Input to control the gate operator. When an Access Device is active, the Access LED will light.

Access Input:

1. Allows external Access Control Devices to activate the gate.
2. If Close Time Delay is ON, gate will open and remain open until the access device relay is released. Then the gate will time out and close.
3. If Close Time Delay is OFF and the gate is in closed or open position, gate will travel in the opposite direction.
4. If Close Time Delay is OFF and the gate is in mid cycle, the gate will stop. The direction will not be changed until another valid input is made.

Connecting Access Devices:

1. Connect Access Control Device relays to ACCESS and COMMON. (Most devices use Normally Open & Common)
2. Only connect devices that are in line of sight to this input. If the access device is not in line of sight, connect it to the radio input.

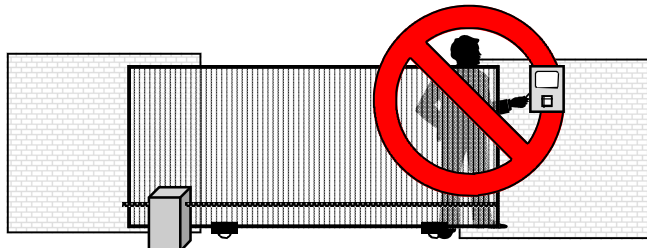

DO NOT mount operating devices accessible through the gate or in between the gate and wall.

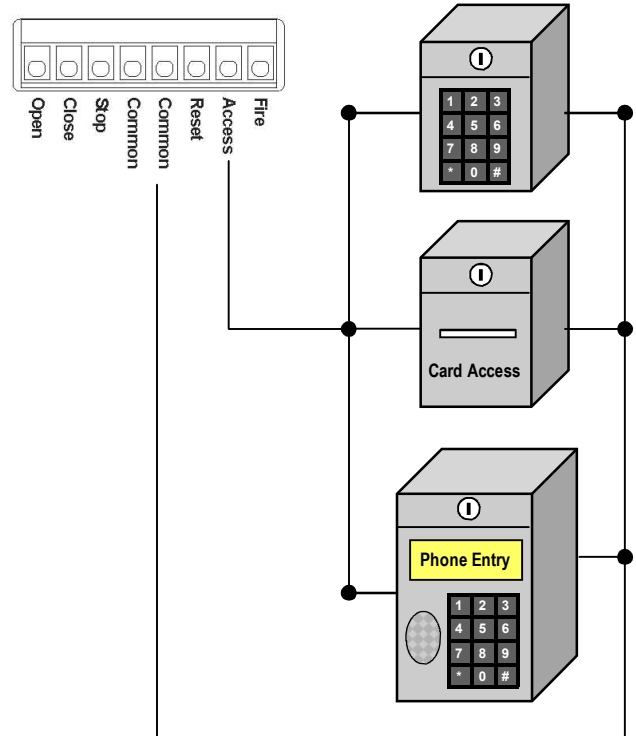

FIRE LOCK CONNECTION:

Fire Lock Controls such as Knox Locks and Fire Boxes may be connected to the Fire Input to control the gate operator. When a Fire Lock Control is active, the Fire LED will light.

Fire Input:

1. Allows Fire Lock Controls to activate the gate.
2. This input knows the position of the gate and will only open the gate when activated.
3. If Close Time Delay is ON, gate will open and remain open until the fire control relay is released. Then the gate will time out and close.
4. If Close Time Delay is OFF and the gate is in closed position, gate will open and remain open until an external input of any sort closes the gate.
5. If Close Time Delay is OFF and gate is in open position, gate will remain open until an external input is made. This prevents the Fire Input from closing the gate if in the open position.

Connecting Access Devices:

1. Connect Fire Lock Control relays to FIRE and COMMON. (Most devices use Normally Closed & Common)

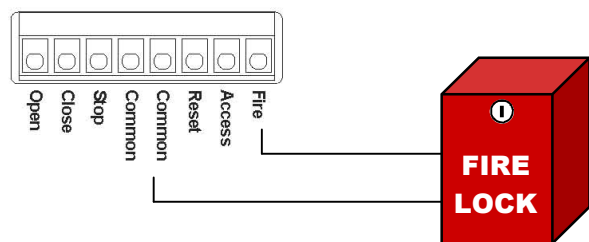

NOTE: Consult your local Fire Department for proper building codes and Fire Lock requirements.

ACCESSORY CONNECTIONS

RADIO RECEIVER CONNECTIONS:

Radio Controls may be connected to the Radio Inputs to control the gate operator. When a Radio Control is active, the Radio LED will light.

Radio Input:

1. Allows Radio Controls to activate the gate and provides 24VDC.
2. NOTE: Wireless Edge Sensor Receivers should be connected to the Edge Terminals. See page 19.
3. The Radio Input will not activate if the gate has been stopped due to an entrapment action.

Connecting Radio Receivers:

1. Connect Radio Relay to RADIO N.O. and RADIO COMMON.
2. If the Radio Receiver uses 24VDC, connect Radio Power to RADIO PWR +24VDC and RADIO PWR -24VDC.
3. Use the following chart for standard radio connections:

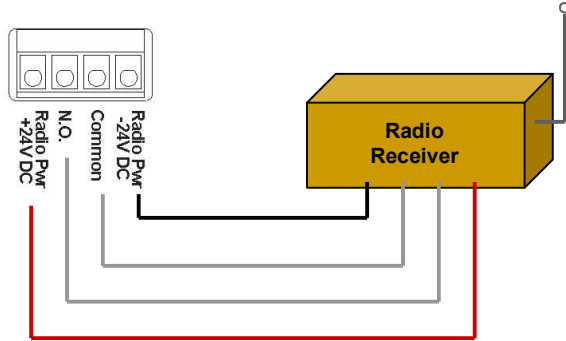

	FAAC	LiftMaster	Linear	Multi-Code
+24VDC				Red
N.O.				Gray
Common				Gray
-24VDC				Black

MAGLOCK & SOLENOID LOCK CONNECTIONS:

Magnetic and Solenoid Locks may be connected to the controller and utilize a 2 second delay on open to help dissipate magnetic current or solenoid power for smoother openings.

MagLock & Solenoid Inputs:

1. Allows Maglocks and Solenoid Locks to be connected to the gate operator with a 2 second delay to open.
2. Maglocks use a NC relay contact. Solenoid Locks use a NO contact.
3. Function: Operators delay 2 seconds to open, Slave opens first followed by Master. Master closes first followed by Slave.

Connecting Solenoid & Maglocks:

1. Set DIP Switch 10 to ON for a 2 second delay on open.
2. Connect Solenoids to SOLENOID NO and SOLENOID COM.
3. Connect Maglocks to MAGLOCK NC and MAGLOCK COM.

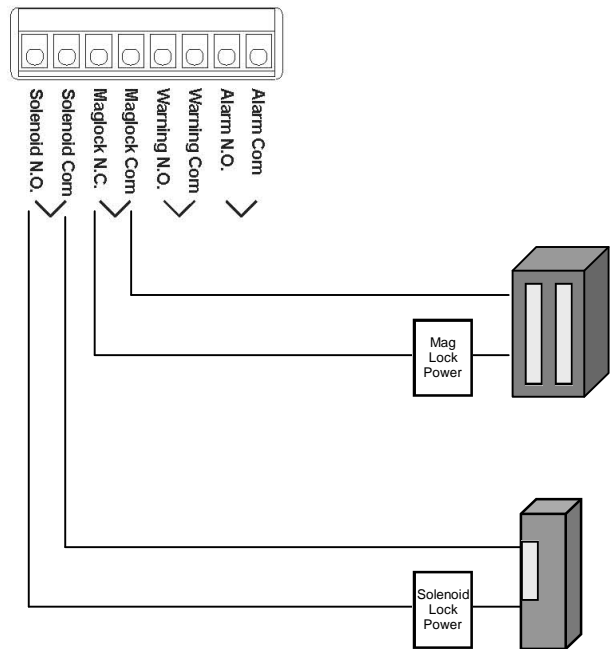
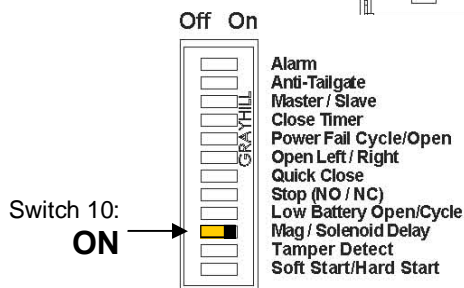

ACCESSORY CONNECTIONS

ALARM & WARNING LIGHT CONNECTIONS:

An external Alarm and/or external Warning Light may be connected to the gate operator. Devices connected to these terminals will be active during shutdown applications and while the gate is in motion both open and closed if desired.

Alarm & Warning Inputs:

1. Allows an external Alarm to be active during shutdown applications and also during gate motion if desired.
2. Allows external Warning Light to be active during gate motion.

Connecting External Alarm & Warning Light:

1. Connect Warning Light to WARNING NO and WARNING COM.
2. Connect Alarm to ALARM NO and ALARM COM.
3. Set DIP Switch 1 to OFF for the Alarm to only sound in shutdown applications.
4. Set DIP Switch 1 to ON for the Alarm to beep while gate is moving and sound the alarm in shutdown applications.

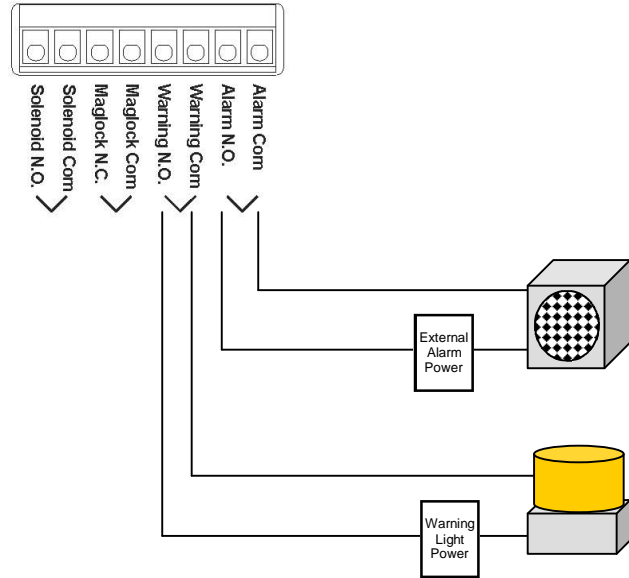

SOLAR PANEL CONNECTIONS:

For applications where AC Power drops out on a regular basis, an optional Solar Panel may be installed to help keep the batteries charged. (Please note: Solar and battery backup power are for limited operations and not intended for high traffic applications. Fully charged batteries can operate a gate from 5 - 100 times depending on the application. Heavy gates, on hills, with poor hardware are going to operate fewer times than light gates, level, with good hardware.)

Solar Panel Inputs:

1. Allows an optional Solar Panel to be connected to the system for added charging.
2. Output is limited to sunlight, gate application, battery size, and Solar Panel output. To increase capacity, increase the size of each Solar Panel.

Connecting Solar Panels:

1. Use one 20 Watt, 24VDC Solar Panel **OR** two 20 Watt, 12VDC Solar Panels together in series.
2. Connect the Solar Panel positive to SOLAR +
3. Connect the Solar Panel negative to SOLAR -

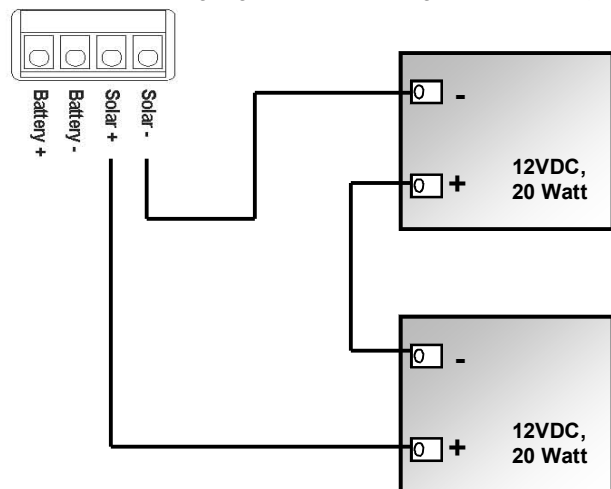

⚠ Batteries should be tested regularly for proper battery backup operation. Batteries should be replaced each year or as needed.

LOOPS & LOOP DETECTORS

BASIC LOOP LAYOUT:

The following diagram shows a typical slide gate application for two-way traffic or exit traffic. For one-way entry traffic, the exit loop is not needed. (This diagram is a basic loop layout and does not show safety devices, pedestrian gate, fencing, etc. Refer to **IMPORTANT SAFETY INFORMATION** for gate details.)

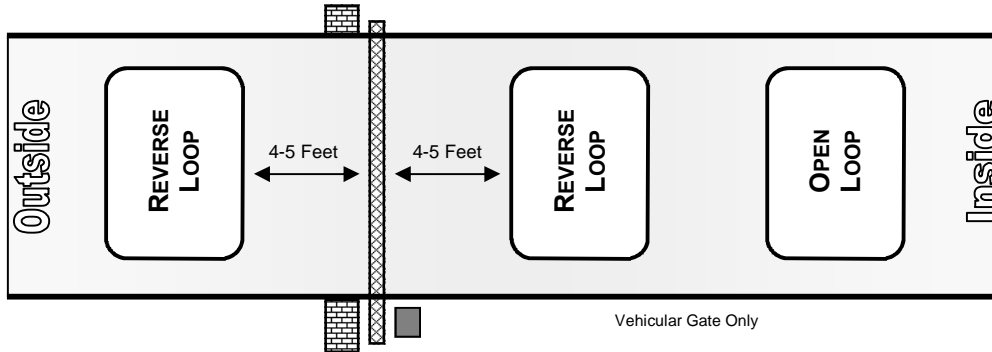

LOOP INSTALLATION GUIDELINES:

Proper loop installation is a critical aspect of any gate application. An improperly installed loop may operate intermittently causing false triggers, holding the gate open, or allowing the gate to close on traffic. The following guidelines should be followed when installing loops:

1. Determine proper location and size of each loop. Chalk out loops on the driveway:
 - Loops should be 4 - 5 feet back from the gate path. Loops any closer may cause false activation when the gate passes by.
 - Determine the size of the loop. Make the loop large enough so a vehicle must pass over the loop. The average loop is 4x8. Consider the detection height.
 - Determine the detection height. The typical sensing height is 2/3 of the shortest leg. (Example: a 4x8 loop typically has a detection height of 2 1/2 feet.) To increase the detection height, increase the loop size.
2. Cut loop slots in the driveway:
 - Loop slot should be 1 1/2+ to 2+ deep.
 - Loop slot should be 1/4+ wide.
3. Install loop wire:
 - Recommended Wire: 14 AGW to 18 AGW Stranded XLPE.
 - Starting at the gate operator, install the loop wire into the lead and loop slots. Use one continuous run of wire for the loop.
 - Install the appropriate number of turns as determined by total loop square footage. (Use attached chart)
 - Twist lead wires at least 6 turns per foot from the loop to the loop input. (Hint: Pull the lead wires tight from the corner of the loop and twist using a power drill.)
 - Route the lead wires to the edge of the driveway and into rigid conduit under ground. Seal this joint to protect the wires.
 - Press the loop wire to the bottom of the loop slot. Use Backer Rod (foam rubber) to protect and keep the loop wires from rising when the sealant is poured.
 - Seal the loop slots with a sealant. Make sure the sealant is able to sink to the bottom of the loop slot and completely encase the loop wire. The wire should not move when the sealant has set.

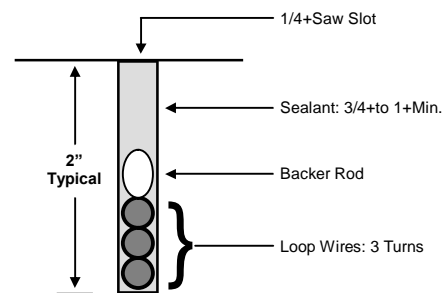
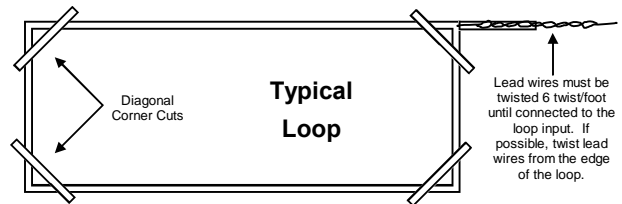

Loop Size (Sq. Feet)	Number Of Turns
6qto 12q	6
13qto 20q	5
21qto 60q	4
61qto 240q	3
241q& Up	2

LOOPS & LOOP DETECTORS

PLUG-IN LOOP DETECTOR CONNECTIONS:

The gate operator may utilize PLD1500 Plug-in Loop Detectors to simplify installation, save space and eliminate extra wiring. There are three plug-in terminals (Shadow, Reverse, Open) located on the gate controller. Detectors plugged into a specific socket will perform that function. To connect a PLD1500:

Plug-In Loop Detector Inputs:

1. Shadow Loop: Not used on DSL2000.
2. Reverse Loop: Plug detector into center socket. Make sure detector is secure and snapped in.
3. Open Loop: Plug detector into left socket. Make sure detector is secure and snapped in.
4. Set different frequencies for each loop detector.
5. Follow the directions provided with the PLD1500 for more detailed settings.

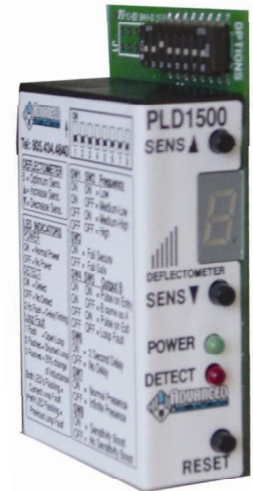
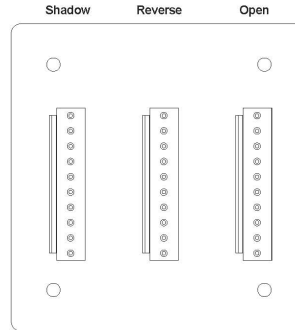

Ground Loop Wire Connections:

1. Connect Reverse Loop wires to REVERSE 1 and REVERSE 2.
2. Connect Open Loop wires to OPEN 1 and OPEN 2.

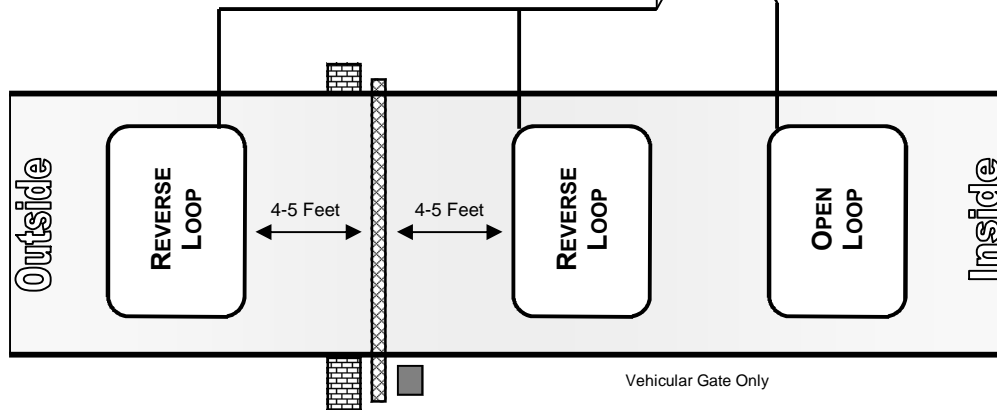
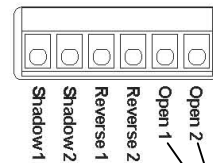

EXTERNAL LOOP DETECTOR CONNECTIONS:

The gate operator may utilize external Loop Detectors. Refer to the manufacturer's instructions for detailed wiring.

External Loop Detector Inputs:

1. 24VDC is available to power external loop detectors. Connect 24VDC detector power to +24VDC and COMMON.
2. Shadow Loop: Not used on DSL2000.
3. Reverse Loop: Connect relay wires to REVERSE N.O. and COMMON.
4. Open Loop: Connect relay wires to OPEN N.O. and COMMON.
5. Set different frequencies for each loop detector.
6. Follow the directions provided by the external loop detector manufacturer for more detailed settings.

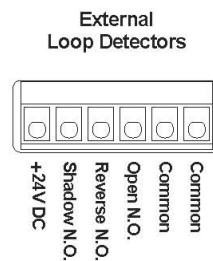

TROUBLESHOOTING TIPS

FAULT LIGHT COUNT:

The gate operator control board has a Fault Light to help determine fault shutdowns. If the operator is not functioning properly, remove the cover and check the Fault Light for the operator Fault Status. Use the following chart to determine the Fault:

Number of Blinks	Fault Description	Cause & Action
1	Sensitivity/Current Overload: First Time	Operator detected an unexpected current overload while moving. Usually caused by the gate hitting an obstruction or tripping the sensitivity. This will put the operator in a Soft Shutdown. <ol style="list-style-type: none"> 1. Make sure the sensitivity settings are set correctly. Too light of a setting will cause the gate to stop and fault. 2. Make sure there are no external obstructions that are causing the gate to stop and shutdown.
2	Sensitivity/Current Overload: Second Time	Operator detected an unexpected current overload while moving a second time. Usually caused by the gate hitting an obstruction or tripping the sensitivity. This will put the operator in a Hard Shutdown. <ol style="list-style-type: none"> 1. Make sure the sensitivity settings are set correctly. Too light of a setting will cause the gate to stop and fault. 2. Make sure there are no external obstructions that are causing the gate to stop and shutdown.
3	Run Time Fault	Operator has run longer than normal. Usually caused by a bad limit or limits being miswired. <ol style="list-style-type: none"> 1. Check the limit for normal operation. 2. Make sure the limit wires are tight and wired correctly.
4	Sensor Fault/Failure	Motor Sensors have failed. Usually caused by a bad sensor or loose sensor wire. <ol style="list-style-type: none"> 1. Make sure the sensor wires are tight and well connected to the blue connector. While the operator is stopped, wiggle the Limit/Sensor connector. If the limit or sensor wires blink on and off, there is a loose connection. 2. Start the operator, watch Sensor 1 and Sensor 2 at startup. They should both blink before turning solid. If only one blinks, then the non-blinking sensor is not being seen. 3. Remove the motor from the gearbox. Both sensor lights should be on. Pass a flat screw driver between Sensor 1 and Sensor 2 on the motor plate. The Sensor LED on the control board should turn off and on as the screw driver passed through it. 4. Make sure the sensor cup on the gearbox shaft is tight. There are set screws in the collar. A loose sensor cup will slip and cause the sensors to miss counts.
5	PCB Overheat Fault	Operator PCB has become too hot and caused a fault. <ol style="list-style-type: none"> 1. Make sure the control board heat sink is secured to the side of the controller box to help dissipate excess heat. 2. Determine if the operator has run excessively to cause an overheating problem. 3. Possibly a defective heat sensor on the control board. Have board repaired.
6	Master Slave Fault	Master Slave communication has failed. Usually caused by a loose Master Slave wire or connector. A very strong lightning strike can sometimes cause damage to the master slave circuit on the control board. <ol style="list-style-type: none"> 1. Make sure the master slave wires are connected correctly and tight. 2. Route the master slave wire up over the control box to help pull the connector tighter against the top of the plug pins. Tightly routing under the controller can cause the connector to pull away from the plug pins and cause intermittent faults. 3. Unplug the master slave wire and set both operators as Masters. Test each operator independently to make sure there are no other problems or faults. After determining each operator runs by itself, reset the master slave settings and connect the master slave wire. If the problem continues, recheck wire and wire connections. 4. Run a new CAT5 wire on top of the driveway to test the master slave communication. This will determine if the underground wire is good or bad. 5. Possible damage to the control board master slave components. Have boards repaired.

LIMITED WARRANTY

You MUST read, understand and agree with ALL items in this limited warranty!

FAAC warrants this product to be free of defects in workmanship and materials for a period of (1) one year from the date of purchase. FAAC reserves the right of final determination to the cause of any defect or failure. FAAC shall, at its option, either repair or replace this product if returned freight prepaid to FAAC during the warranty period. This warranty does not include freight, taxes, duties, or installation and service expenses. This warranty will not apply to circumstances which are considered beyond our control including: incorrect installation or application, vandalism, misuse, acts of God (lightning, insects and rodents, floods, etc), power surges, or improper system installation.

The warranty set forth above is exclusive and no other warranty, whether written or oral, is expressed or implied. FAAC specifically disclaims any implied warranties or merchantability and fitness for a particular purpose. The remedies provided herein are the buyer's sole and exclusive remedies. In no event shall FAAC be liable for direct, indirect, special, incidental or consequential damages (including loss of profits or property), whether based on contract, tort or any other legal theory. FAAC can not be held responsible for damage or injury caused by improper, erroneous or unreasonable use or installation. The installer and end user agree to assume all responsibility for ALL liability in use of this product releasing FAAC of all liability.

IMPORTANT: It is the joint responsibility of the installer and end user to verify the system is properly configured for its intended use including proper safety devices. Failure to comply with these guidelines may create a dangerous situation and will void any and all warranties. All users must follow and understand:

1. A moving gate can cause serious injury or death. Read and follow all installation manuals, reference manuals, and warning label instructions.
2. Vehicular gates are for vehicles only. Pedestrians must use a separate entrance. Keep all pedestrian traffic away from any vehicular gate. No one should cross the path of a moving gate.
3. Never allow children to operate or play with gate controls. Never allow children to play in the area of a gate system.
4. Access control devices must be placed far enough from moving gates to prevent the user from coming in contact with the gate while operating the controls.
5. All activating devices must be installed in a clear line-of-sight with the gate and its travel.
6. Activating devices must be installed a minimum of 10 feet away from the gate.
7. Outdoor or easily accessible controls shall have a security feature to prevent unauthorized use.
8. Be sure to mount all operating devices clearly out of reach of through gates.
9. Any required contact edges and/or photo beams must be installed before placing this system into operation.
10. Make sure all residents and users are familiar with the proper use of this equipment and its potential hazards.
11. Protect against all pinch and entrapment points. **If entrapment points can not be protected, DO NOT install this equipment.**
12. Read and follow all U.L. and Safety Standards before installing any access device.
13. Installation, service and maintenance must be carried out by qualified personnel.

In order to install and use this system, the installer and end user must understand and be in FULL unconditional agreement with all stipulations outlined above. If you are not in FULL agreement, do not put the system into operation. If the system is put into operation, this will confirm that you are in FULL unconditional agreement with all of the above stipulations.

Customer's Signature Date

Installer's Signature Date



Read and follow all U.L. and Safety Standards before installing any access device. Please refer to this manual and qualified personnel for assistance. DO NOT install this device unless all entrapment and pinch points are eliminated.

The Customer and Installer should retain a copy of this signed warranty.