

# VELA INDUSTRIAL

ELECTRO-HYDRAULIC BARRIER GATE FOR INDUSTRIAL USE AND LONG BEAM



Compliant to UL 325

VELA INDUSTRIAL is an hydraulic barrier for industrial use.

- Maximum beam length: 24,6 feet.
- By-pass valve for torque regulation.
- Opening time: from 8 to 12 seconds.
- Hydraulic slow down.
- Metal fork for a higher lasting performance.
- Metal case.
- Control board: GATE 1.
- Duty Cycles\*: 75% rate of use.

\* Duty Cycles depend on installation

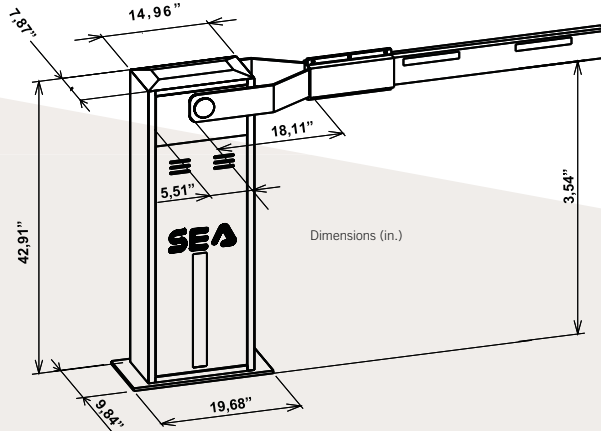

### ACCESSORIES

Code	Description	Price \$
11905010	Rigid beam 19,7 ft.	
11905015	Rigid beam 23 ft.	
11905020	Rigid beam 24,6 ft.	
16200105	Fork support for Vela beam	
16200085	Foundation plate for Vela	

### ACCESSORIES

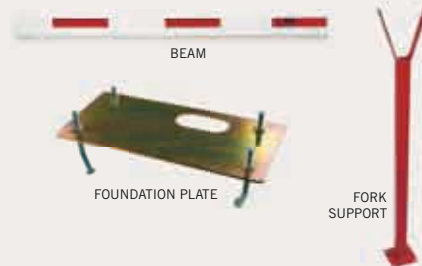

### SPECIFICATIONS

Code	Description	Power	Max beam length	Cycles	Operator weight	Opening time	Price \$
117AC4L06M	Vela Industrial left BRAKE	1/3 HP	24,6 feet	Intensive	160 pounds	12 sec	
117AC4R06M	Vela Industrial right BRAKE	1/3 HP	24,6 feet	Intensive	160 pounds	12 sec	
117AC4L0	Vela Industrial left BRAKE	1/3 HP	23 feet	Intensive	160 pounds	10 sec	
117AC4R0	Vela Industrial right BRAKE	1/3 HP	23 feet	Intensive	160 pounds	10 sec	
117AC4L01	Vela Industrial left BRAKE	1/3 HP	19,7 feet	Intensive	160 pounds	8 sec	
117AC4R01	Vela Industrial right BRAKE	1/3 HP	19,7 feet	Intensive	160 pounds	8 sec	