



# Verg - L 24V

24V ELECTROMECHANICAL BARRIER FOR BEAMS UP TO 5 M /16,4 FEET FOR LIGHT/MEDIUM DUTY CYCLES



- Fast low voltage automatic barrier.
- Slow down speed adjustable in opening and closing
- **Electric motor with low consumption**
- Reverse on obstacles with adjustable sensitivity
- Battery back-up to guarantee the operating also in case of power failure
- Optional solar panel KIT SUNNY
- Control board USER 1 - 24V DG.
- Adjustable mechanical stops
- Cataphoresis treated and polyester painted steel box for longer life  
INOX stainless steel box available (on request)
- Oval beam with protection rubber and optional STRIP LED light
- The electronic control board (USER 1 - 24V DG) is positioned on the top and in a horizontal position to allow an easier use during installation or maintenance
- Universal right / left hand side.



Electronic control unit positioned on the top of the carter



Electric motor with low absorption



Easy release system with key in case of power failure

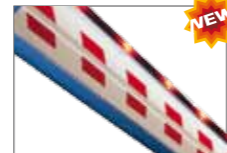

Strip red light Led - IP 67



Case opening

CODE	NAME	OPENING TIME	MAX BEAM LENGTH	FREQUENCY OF USE (%)	PCS FOR PALLET
1132S0-5MT-CSA	VERG L 24V DC	adjustable	16,4 feet	60%	8

Foundation plate included

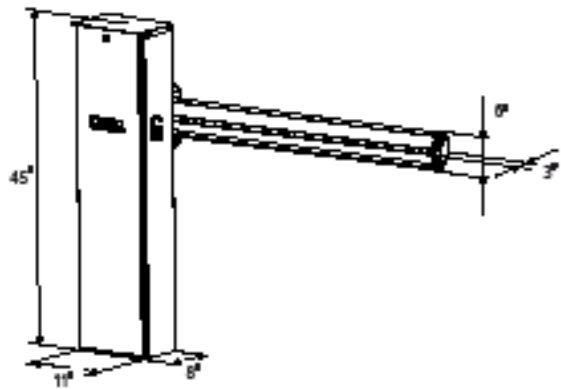

Dimensions (inches)

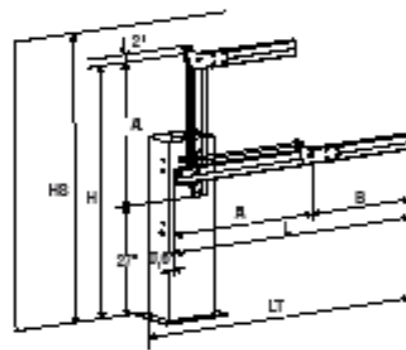

Articulated beam

### PACKAGE VERG

- N.1 Operator VERG L 24V
- N.1 Control board USER 1 - 24V DG
- N.1 Installation accessories kit
- N.1 Installation instruction and general notice
- N.1 Foundation plate
- N.1 Warning board

### ASSEMBLED BEAMS



11903050

**KIT LIGHT3 TH - 10 feet**  
Beam + balancing spring + blunt-free rubber + profile LED (Sticker not included)

11903055

**KIT LIGHT4 TH-13 feet**  
Beam + balancing spring + blunt-free rubber + profile LED (Sticker not included)

11903060

**KIT LIGHT 5 TH- 16,5 feet**  
Beam + balancing spring + blunt-free rubber + profile LED (Sticker not included)

### ACCESSORIES



23105441

**STRIP LED**  
Red light IP 67 16,5 feet with power supply 1Ah

11902035 (\*\*\*)

**LIGHT-ART 3**  
Articulated oval beam up to max 10 feet (beam and spring)

12715220 (\*\*)

**STICKER**  
Red Sticker for beam (pack of 164 feet-50 m)

16200045

**CSUPLIGHT**  
Counter plate for fork support

12710795

**RAPID RELEASE 3**  
Beam break-away system with round beam of 10 feet 70 mm diameter

12710796

**RAPID RELEASE 4**  
Beam break-away system with round beam of 13 feet 70 mm diameter



23101104

**ESUN Q**  
Battery charger 800 mA with solar panel admin

23106430 \*

**Kit SUPER SUNNY 85W**  
85W solar panel + charger +battery 33Ah

10920805-I

**SF**  
Fork support

NB: ESUN Q 23101104 to combine with BAT7 23106305  
(\*) Plastic box not included

\*\* Same length of the beam needed  
\*\*\* The STRIP LED can be used only for the first part of the beam just up to the articulation  
Note: For 13/16,5 feet beams it is recommended to install 10920805-I  
NB: LIGHT-ART on request cut up to 10 feet following the drawing  
NOTE: Respect the opening times in relation to the length of the beam (see instruction manual)