

# INSTALLATION AND OWNER'S MANUAL

## MODEL "EMG" Explosion Proof Operator

# PowerMaster

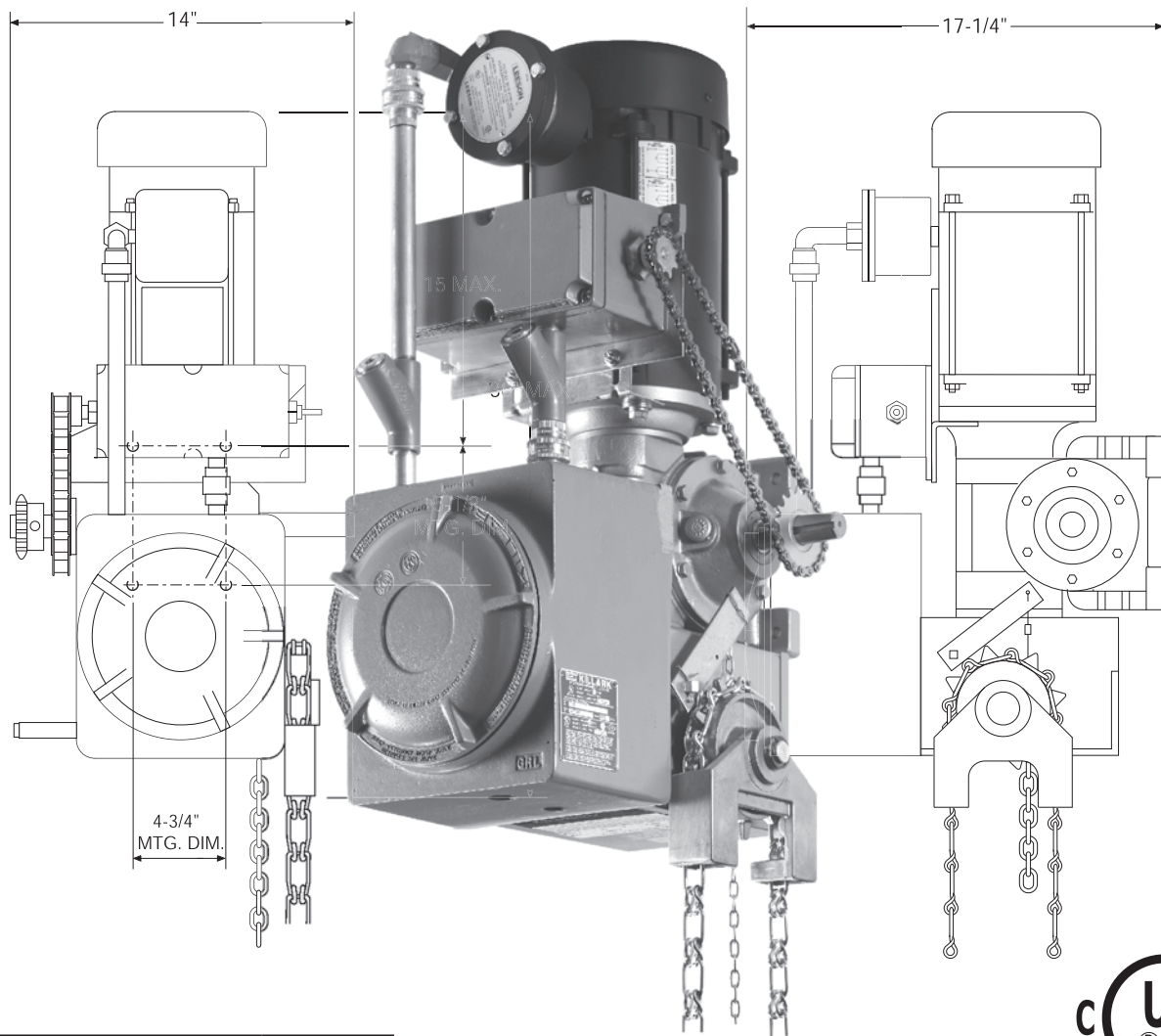

<b>Serial #:</b>
<b>Date Installed:</b>
<b>Your Dealer:</b>

READ THIS MANUAL CAREFULLY  
BEFORE INSTALLATION OR USE.  
SAVE THESE INSTRUCTIONS



**LISTED**

As of date of manufacture,  
meets all ANSI/UL 325  
Safety Requirements for  
Vehicular door operators.

EMG Operator Applications .....	3
Preparation .....	4
Figure 1 - Component Identification Pictorial .....	4
Important Installation Warnings (Things To Do Before & During Installation) .....	5
Table 1 - Component Identification Listing .....	5
Door Types and Mounting Positions .....	6
Installation Instructions .....	7
Figures 5-9, Installation Pictorials.....	8
Setting The Limits.....	10
Electrical Wiring Instructions .....	11
Figure 16 - Pneumatic Door Edge Installation .....	12
Figure 17 - Field Wiring .....	12
Wiring Diagram - Single Phase (EX31).....	13
Wiring Diagram - Single Phase (EX31-IS/FS) .....	14
Wiring Diagram - Three Phase (EX33).....	15
Wiring Diagram - Three Phase (EX33-IS/FS) .....	16
Operation and Adjustment Instructions .....	17-19
Important Safety Instructions for Owner .....	17
Wiring Terms .....	17
Testing .....	18
Maintenance .....	19
Troubleshooting.....	20
EMG Exploded View .....	21-26
Warranty .....	27
Technical Hotline .....	28

## READ THESE STATEMENTS CAREFULLY AND FOLLOW THE INSTRUCTIONS CLOSELY!

The Warning and Caution boxes throughout this manual are there to protect you and your equipment. Pay close attention to these boxes as you follow the manual.

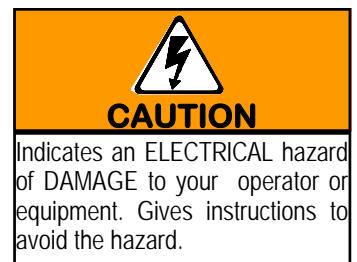
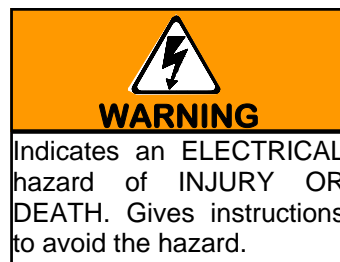
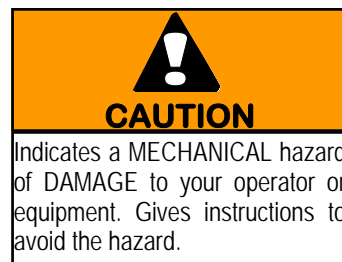

The purpose of this booklet is to provide assembly, installation and operation information concerning PowerMaster EMG Commercial Vehicular Garage Door Operators and related Accessory Products.

**NOTE:** IT IS IMPORTANT THAT THIS INSTRUCTION MANUAL BE READ AND UNDERSTOOD COMPLETELY BEFORE INSTALLATION OR OPERATION IS ATTEMPTED. IT IS INTENDED THAT THE INSTALLATION OF THIS UNIT WILL BE DONE ONLY BY PERSONS TRAINED AND QUALIFIED IN THE INSTALLATION, ADJUSTMENT AND SERVICE OF COMMERCIAL OVERHEAD DOORS AND DOOR OPERATORS AND BY QUALIFIED ELECTRICIANS.

**NOTE:** THE IMPORTANT SAFEGUARDS AND INSTRUCTIONS IN THIS MANUAL CANNOT COVER ALL POSSIBLE CONDITIONS AND SITUATIONS WHICH MAY OCCUR DURING ITS USE. IT MUST BE UNDERSTOOD THAT COMMON SENSE AND CAUTION MUST BE EXERCISED BY THE PERSON(S) INSTALLING, MAINTAINING AND OPERATING THE EQUIPMENT DESCRIBED HEREIN. DO NOT USE THIS EQUIPMENT FOR ANY OTHER APPLICATION THAN ITS INTENDED PURPOSE - OPERATING OVERHEAD COMMERCIAL VEHICULAR GARAGE DOORS.

## **STANDARD FEATURES:**

**Limit Switches:** Rotary limit switches, easily adjusted over a wide range. The motor may be removed without affecting the limit switch adjustments.

**Manual Release:** Permits manual operation of the door in the event of a power failure. The Model MG is equipped with a chain hoist to aid in manual operation and its use will not affect limit settings.

**Control Circuit:** 24 Volts AC. Standard three button open, close and stop supplied. Will accept all standard control devices.

**Connections For Auxiliary Entrapment Protection Devices:** Use with foam or pneumatic reversing door edge components or a photoelectric beam (across the opening) device.

**Momentary Contact To Close:** Feature can be activated by simply moving a wire on the terminal strip.

**Constant Contact To Close:** Standard operation.

## **MODEL EMG OPERATOR APPLICATIONS:**

EMG operators are intended for commercial and industrial use to raise or lower rolling steel or sectional overhead doors by chain coupling to the door shaft. WMG operators are suitable where all or part of the door remains in a vertical position when fully open such as doors with at least 18 inches of lift clearance or full vertical lift doors. EMG operators may also be used with roll up service doors and grills when specified on order from factory.

An EMG operator **DOES NOT LOCK THE DOOR IN ITS CLOSED POSITION.** However, because the cross-header shaft is prevented by the operator from turning, the torsion springs provide no assistance in lifting the door should an attempt be made to raise it manually.

EMG operators are used in the following applications:

- Continuous Duty, Medium and Heavy Duty Cycle Commercial installations.
- Indoor Use Only
- Doors with a maximum area of 840 square feet (3 HP) - maximum area slightly higher for lighter doors - consult factory
- 5 HP available on Special Order
- Use with foam/pneumatic reversing door edge or photoelectric device - REQUIRED where the 3-button station is out of sight of the door, or any other automatic, remote or manual control is used to activate the door.

## **OPTIONAL FEATURES:**

**Digital Radio Controls:** Open, Close and Stop operation. Radio units are available to control up to 27 doors from one transmitter

**Digital Timer to Close:** Adjustable from 0 to 17 minutes in one second intervals.

**Keyless Entry System:** Connection terminals provided for hard wired keyless entry system. Optional radio receiver will allow operation of a wireless keyless system.



## WARNING

**ELECTRIC DOOR OPENERS ARE DESIGNED FOR DOORS IN GOOD WORKING CONDITION, PROPERLY COUNTERBALANCED AND PROPERLY ADJUSTED IN ACCORDANCE WITH THE DOOR MANUFACTURER'S INSTALLATION INSTRUCTIONS.**

Before starting the installation of the operator, the door must be in good working condition and properly counterbalanced. Inspect the door and door guides for loose or missing hardware. Test the door manually for balance and ease of operation. Lubricate door hinges and rollers. If necessary, employ a qualified technician to adjust the springs for proper counterbalance of the door.

Stops should be installed at the top end of each track to prevent the possibility of the door rollers moving beyond the ends of the track.

If the cross header shaft is made from hollow tubing rather than solid rod, it is recommended that it be plugged with a short length of solid bar for a more secure installation of the shaft sprocket or flange coupler.

Before removing the operator powerhead from the shipping carton,

inspect the nameplate on the cover of the operator control box to verify that it is the correct model for the intended application and that the voltage and phase are in accordance with electrical power provided at the job site.

Warning: Rope off the area to keep personnel and vehicles clear of the door and floor space in the vicinity of the operator during the installation.



## WARNING

**SPRINGS ARE SUBJECT TO VERY HIGH FORCES AT ALL TIMES AND ADJUSTMENTS MUST BE MADE ONLY BY A QUALIFIED PROFESSIONAL DOOR INSTALLER.**



## WARNING

**REMOVE OR DISABLE ANY LOCKING DEVICES FROM DOOR AND REMOVE ALL ROPES.**

## FIGURE 1 - COMPONENT IDENTIFICATION

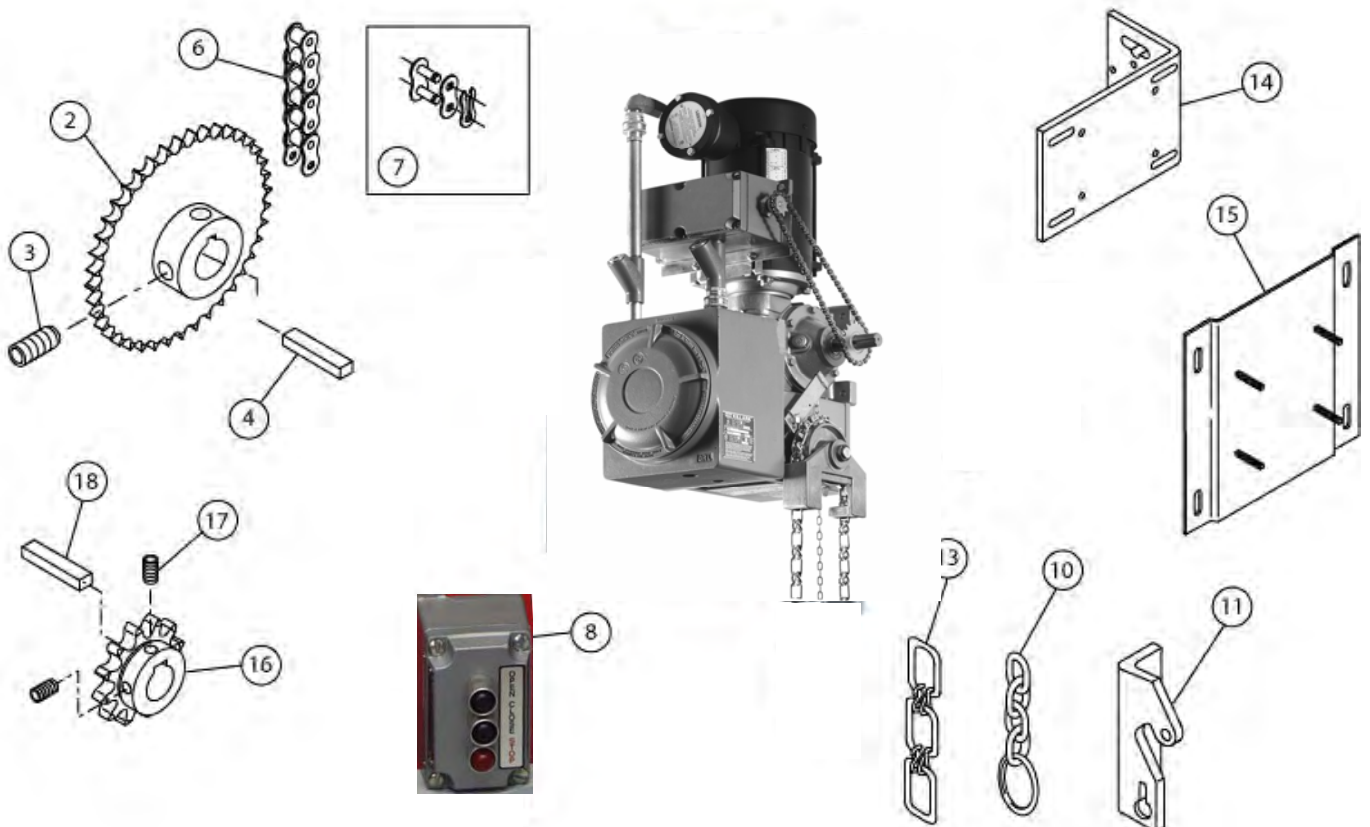



**WARNING**

**TO REDUCE THE RISK OF SEVERE INJURY OR DEATH: READ AND FOLLOW ALL INSTALLATION INSTRUCTIONS!**

- Install only on a properly balanced garage door. An improperly balanced door could cause severe injury. Have a qualified service person make repairs to cables, spring assemblies and other hardware before installing the opener.
- Remove all ropes and remove or make inoperative all locks (unless mechanically and/or electrically interlocked to the power unit) that are connected to the garage door before installing the opener.
- Lightweight doors (fiberglass, aluminum etc.) must be reinforced to avoid door damage. Check the door manufacturer's instruction manual for a bracing procedure or the availability of a Reinforcement Kit.
- The MG Series Operator is a Commercial Vehicular Door Operator and as such is **NOT** recommended for pedestrian traffic. In installations where it is known that pedestrians will be nearby ensure a pedestrian door is available for entrance and exit to the building. In addition **YOU MUST install an auxiliary entrapment protection device (reversing door edge or photoelectric beam device) as part of the complete operator system.**
- Connect an auxiliary entrapment protection device (reversing edge or photoelectric device across the door opening). **A device of this type is STRONGLY ADVISED FOR ALL commercial operator installations.**
- An auxiliary entrapment protection device is **REQUIRED** when the three button control station is out of sight of the door or any other automatic or manual control is used.
- Install the opener at least 8 feet or more above the floor.
- Do not connect the opener to the source of power until instructed to do so.
- Locate the control station:
  - a) within sight of the door and;
  - b) at a minimum height of five feet above the floor and;
  - c) away from all moving parts of the door.
- Do not overtighten the clutch adjustment (when provided) to compensate for a poorly working door.
- Securely attach any WARNING signs or placards to either the door or above the control station as directed (see page 15).
- After installing the opener, all control features must be tested for proper operation (see page 18).

**TABLE 1 - COMPONENT IDENTIFICATION LISTING**

Item #	Description	Qty.	Item #	Description	Qty.
1	Operator Power Head	1	10	Sash Chain, Precut	1
2	Driven Sprocket on Door Shaft	1	11	Chain lock Bracket	1
3	Set Screw, 5/16-18 x 1, Square Head	2	13	Hand Chain, Precut	1
4	Steel Square Key	1	14	Mounting Bracket	Optional
6	Drive Chain	1	15	Wall Mounting Plate w/Studs	Optional
7	Master Link	1	16	Drive Sprocket	1
8	3 Button Station	1	17	Set Screw, 5/16-18 x 5/16 socket head set screw	2
			18	Key, 1/4 x 1/4 x 1	1

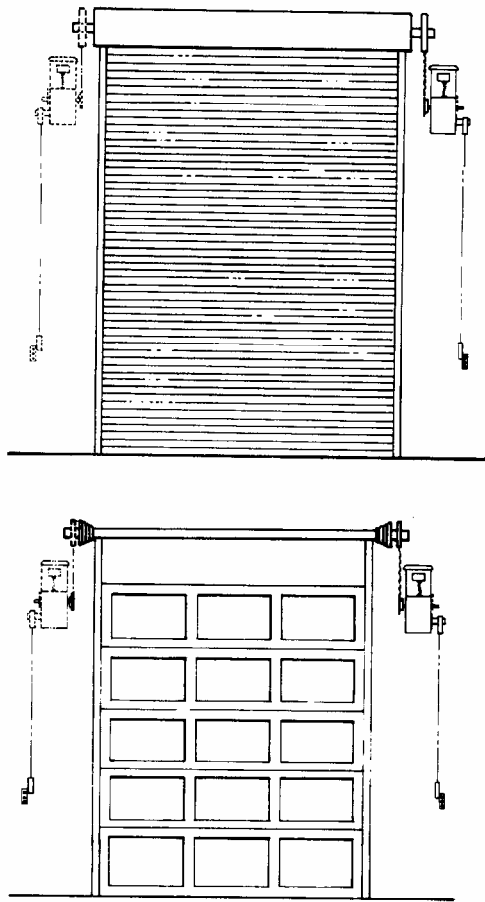

Figure 2

- #1 Vertical Front of Coil, Right Hand
- #2 Horizontal Top Of Coil, Right Hand
- #3 Vertical Wall Mount, Right Hand
- #4 Horizontal Side of Coil, Right Hand
- #5 Horizontal Front of Coil, Right Hand
- #6 Vertical Front of Coil, Left Hand
- #7 Horizontal Top Of Coil, Left Hand
- #8 Vertical Wall Mount, Left Hand
- #9 Horizontal Side of Coil, Left Hand
- #10 Horizontal Front of Coil, Left Hand

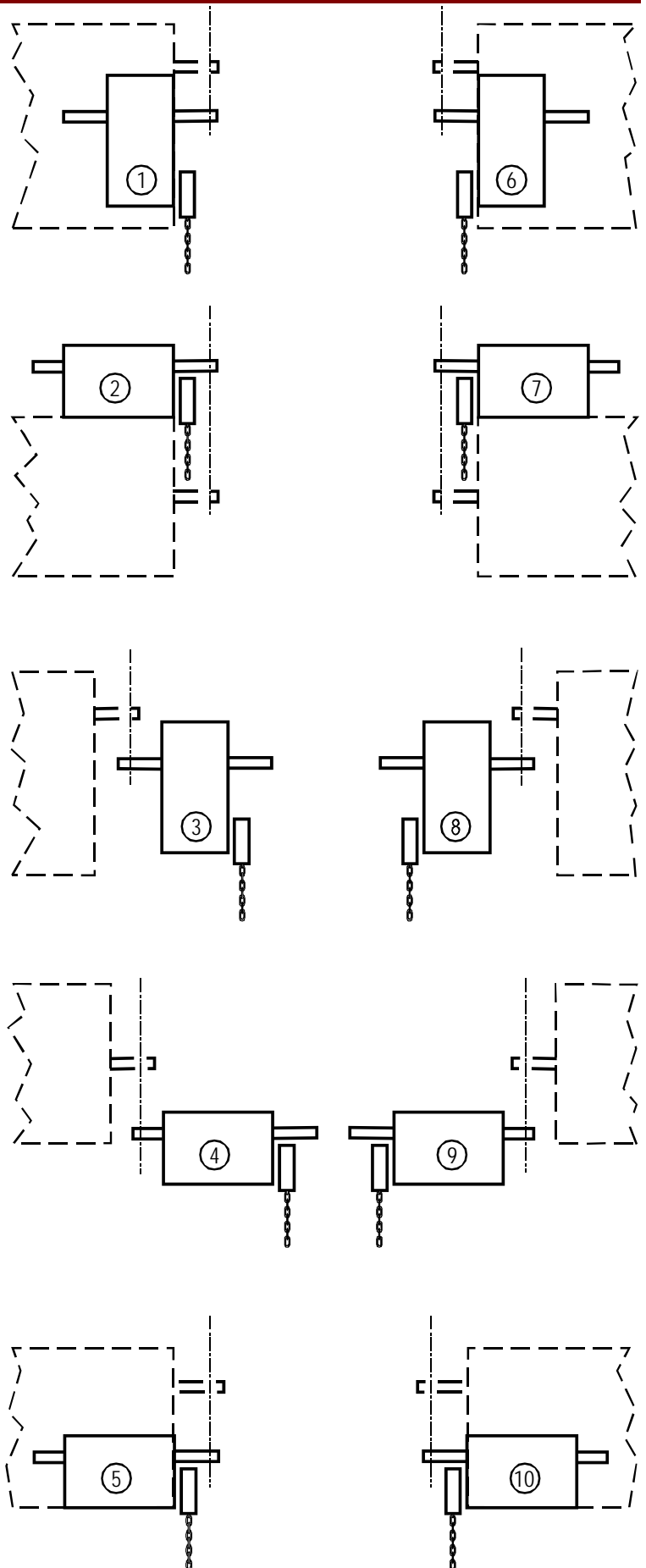

Figure 3





**SPRINGS, PULLEYS, CABLES AND MOUNTING HARDWARE USED TO BALANCE YOUR GARAGE DOOR ARE UNDER EXTREME TENSION AT ALL TIMES AND CAN CAUSE SEVERE INJURY OR DEATH IF DISTURBED. DO NOT ATTEMPT ADJUSTMENT.**

**MOUNTING THE OPERATOR:** WHEN PREPARING THE MOUNTING SURFACE ENSURE THE OPERATOR WILL BE RIGID AND SECURE WHEN INSTALLED, THE MOUNTING SURFACE WILL PROVIDE A LEVEL BASE, AND THE OPERATOR'S DRIVE SHAFT WILL BE PARALLEL WITH THE DOOR SHAFT. FAILURE TO MEET THESE CONDITIONS WILL RESULT IN AN OVERALL UNSAFE DOOR OPERATION AND PREMATURE FAILURE OF THE DOOR AND DOOR OPERATOR.

1. Figures 2 and 3, page 6 illustrates several positions suitable for mounting the operator; right hand or left hand wall mount or horizontal (shelf) mount to the torsion shaft. For sectional doors, the MG operator must be wall mounted. For rolling steel doors the operator may be wall mounted or hood mounted by using an optional hood mounting bracket, [14]. A wall mounting plate [15] is also available from the factory (see Figure 1). The mounting plate/bracket provides for chain tension adjustment as well as aiding installation.

**NOTE: THE OPERATOR DRIVE SPROCKET MAY BE INSTALLED ON EITHER SIDE OF THE GEAR REDUCER. SELECTION DEPENDS ON WHICH SIDE OF THE DOOR THE OPERATOR IS MOUNTED ON.**

2. Determine which side of the door the operator will be located on. Fasten the sprockets [2] and [16] and the keys [4,18] on the chosen side of the torsion shaft of the door and on the corresponding end of the output shaft of the operator. Tighten the set screws enough to prevent the sprockets from sliding off the shaft. If the door shaft lacks a keyway you will need to drill and pin the sprocket in accordance with Step 6 (tightening the set screws is sufficient for this step). The sprockets should be kept as close as possible to the bearings. Fasten the wall mounting plate or the mounting bracket (as applicable and if available) to the operator gear box flange. Temporarily suspend the operator in its mounting position so that the distance between the door shaft and the operator's output shaft is between 12" and 15". See Figure 5 for wall mount and Figure 6 for bracket plate mount illustration. The distance between the shafts may be greater if the mounting conditions prohibit installation as suggested.
3. Connect the two drive sprockets [2 and 16] with the drive chain [6] and connecting link [7], shortening the chain to the proper length if necessary. To shorten the chain use a chain break tool or drive out the appropriate rivets with a

punch.

4. With the chain tight and straight and the operator's output shaft parallel with the door's torsion shaft, trace the mounting slots (holes) on the mounting surface then lower the operator to the floor. The MG operator gear box mounting hole pattern is shown in Figure 4.
5. The operator should be installed using 3/8" bolts through the wall. If the building's construction will not allow the usage of through bolts then use lag bolts and shields (or the equivalent type fasteners). Mount the operator, slipping the drive chain on before bolting the operator to the mounting surface but do not completely tighten the bolts at this time.
6. Re-align the door shaft and operator drive shaft sprockets and connecting drive chain. Secure the sprockets in place with their set screws. If no keyway exists in the door shaft, drill a 3/8" diameter hole through the door sprocket and door shaft with the sprocket in its aligned position. Insert a 3/8" diameter bolt (not provided) through the sprocket hub and shaft. Secure with a lock washer and hex nut. See Figure 7.
7. Adjust the drive chain tension such that there is no more than 1/4" slack when the chain is depressed between the sprockets. See Figure 8. The preferred mounting is with the motor end up and the operator below the door shaft. This results in better clearance for the hand chain and disconnect chain.

**Figure 4**

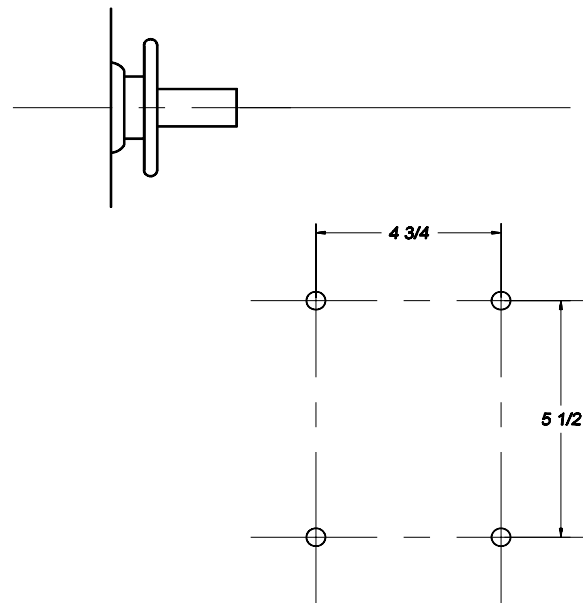

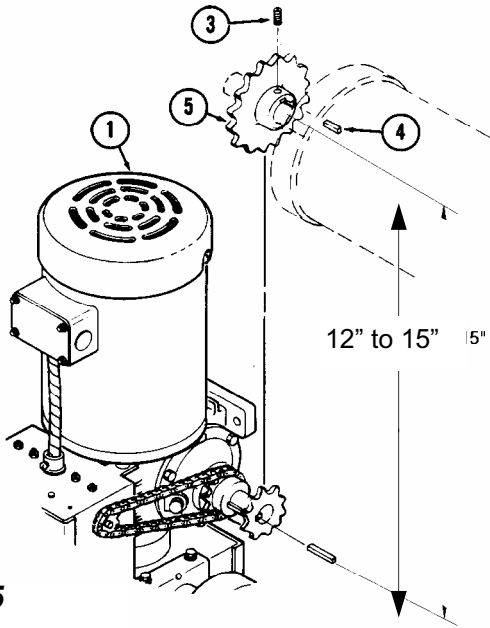

Figure 5

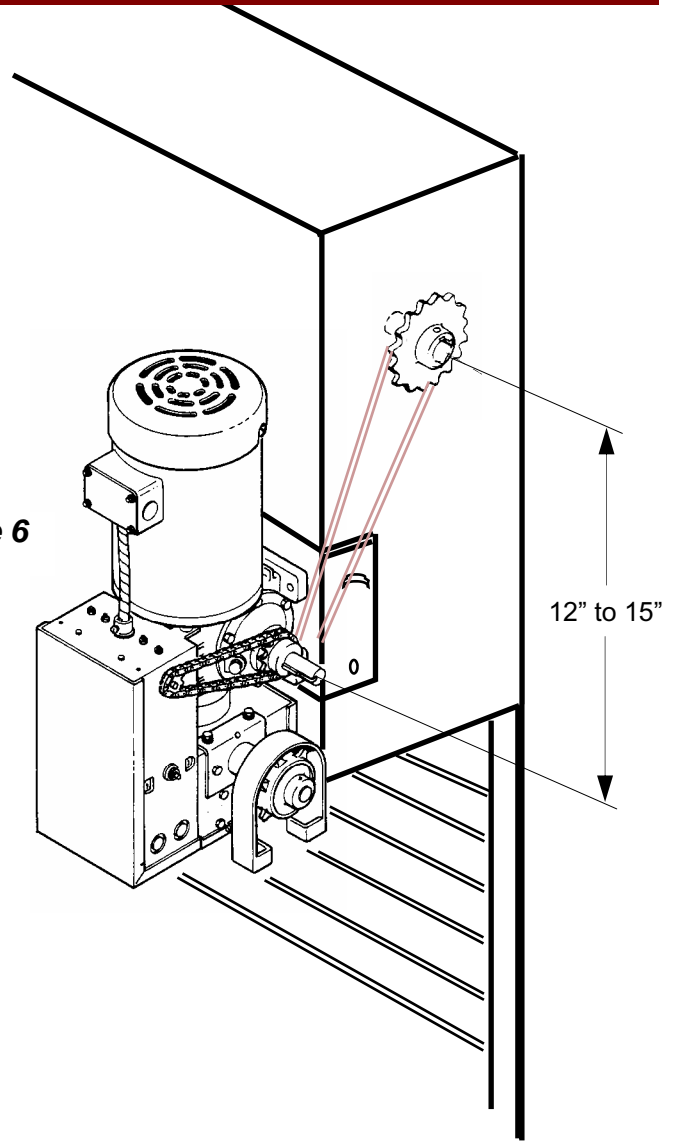

Figure 6

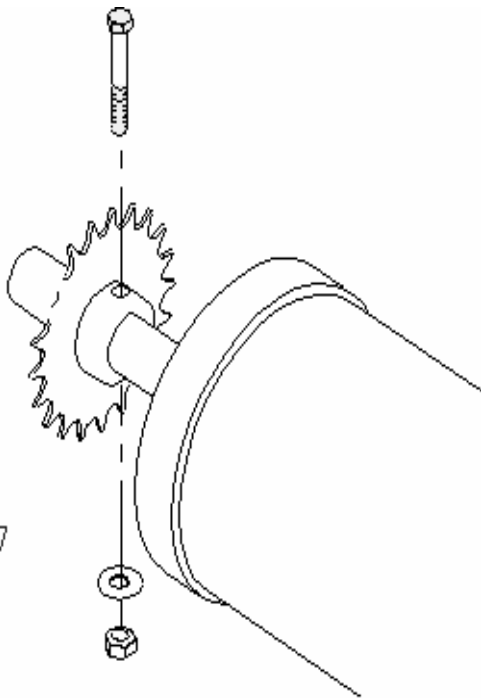

Figure 7

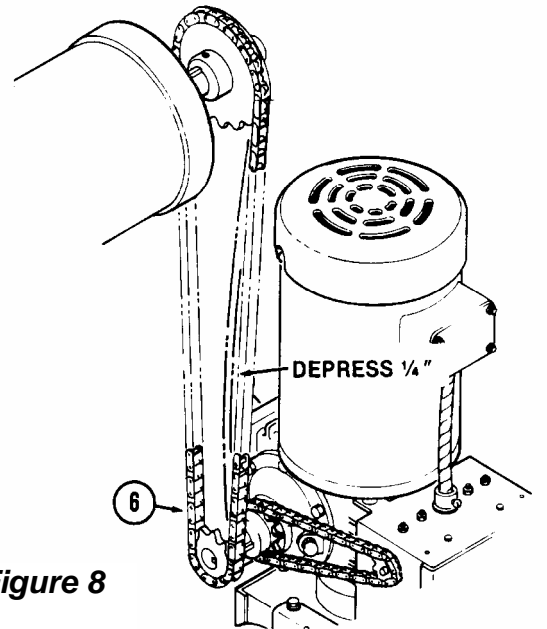

Figure 8



## CHAIN HOIST INSTALLATION

1. Refer to **Figure 10** to install the chain hoist. Pass the hand chain, item 13 over the chain pocket wheel and through the guide holes in the chain guard. Fasten the ends of the chain together (to make one continuous loop) by opening and re-closing one link using two pairs of pliers. If the chain is too long, shorten it to the desired length by removing links.
2. Remove the sash chain from the shipping bag and let hang from the disconnect lever. Pull the sash chain to engage the hand chain. This will actuate the interlock switch and disengage the solenoid brake.
3. Use lag screws to attach the chain lock bracket, item 11, to the wall, vertically in line with the sash chain about four feet off the floor. See **Figure 11**.

**BEFORE PROCEEDING WITH THE OPERATOR INSTALLATION AND SETTINGS, MAKE A FINAL CHECK FOR TIGHTNESS OF ALL MOUNTING HARDWARE AND SET SCREWS.**

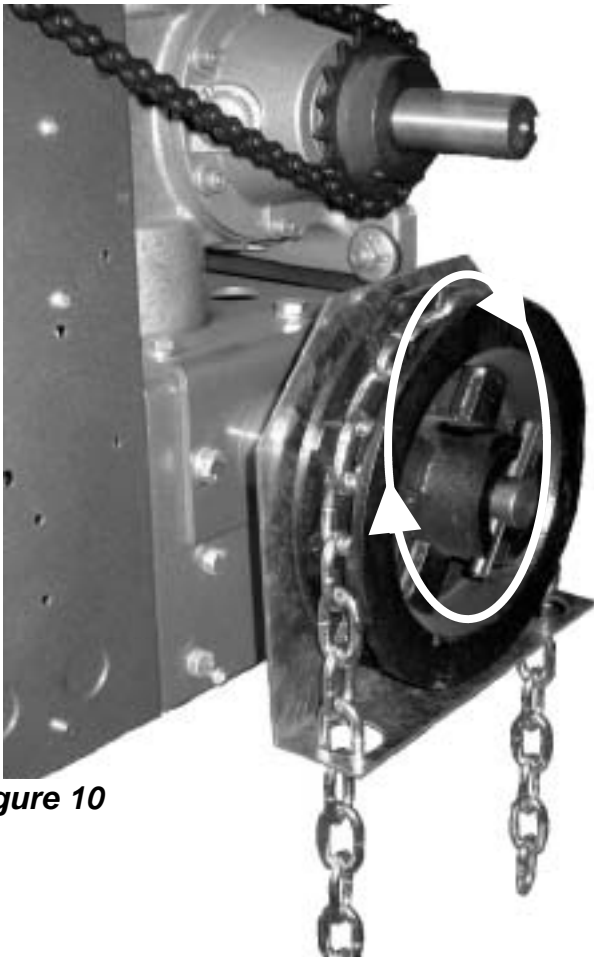

**Figure 10**

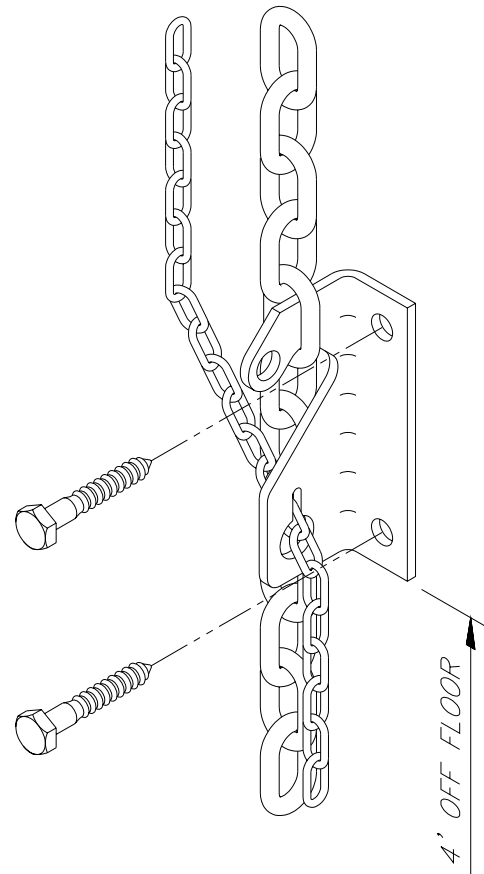

**Figure 11**



## WARNING

TO AVOID RISK OF ENTRAPMENT AND POSSIBLE DAMAGE TO THE DOOR AND OPERATOR THE LIMITS MUST BE ADJUSTED BEFORE APPLYING POWER TO THE OPERATOR.

### SETTING THE LIMIT SWITCHES

1. Open the cover on the electrical enclosure. There are two limit nuts on the threaded shaft that move laterally along the shaft as the operator opens and closes the door. When a limit nut nears the end of the shaft it activates a (set of) switch(es). The OPEN limit switch is on the LEFT and the CLOSE limit switch is on the RIGHT. Auxiliary switches may also be present, they are used to control other functions. These are mounted to a separate bracket and should not be confused with the the OPEN and CLOSE Limit Switches which are mounted to the back of the electrical enclosure box and are somewhat hidden from view.
2. Manually raise the door to a nearly open position.
3. Depress the limit nut retaining bracket away from the slots in the limit nuts. Turn the OPEN limit nut on the shaft until it engages the Open Limit Switch, the switch will sound an audible "click" when engaged. If the Open Limit is a DPDT switch (a total of 6 (six) connecting terminals protruding from the switch body, a SPDT switch has only three (3) terminals), you will need to listen for two audible clicks. Release the retaining bracket and be sure that it engages in slots of both limit nuts.
4. Manually lower the door to a nearly closed position and repeat Step #3 with the Close limit nut and switch.
5. If auxiliary switches are present, the limit nut will actuate them just prior to activating the open or close limit switch. (This is preset at the factory.)
6. Manually move the door to a half open position to avoid door damage due to incorrect power supply phasing. On three phase units the door may initially run in the wrong direction when power is first applied. With the door in a mid position there will be time to stop the door before damage can happen if incorrect phasing occurs.
7. A final limit adjustment will be necessary after the connection of the power supply in order to ensure the door stops at the proper Open and Close positions.

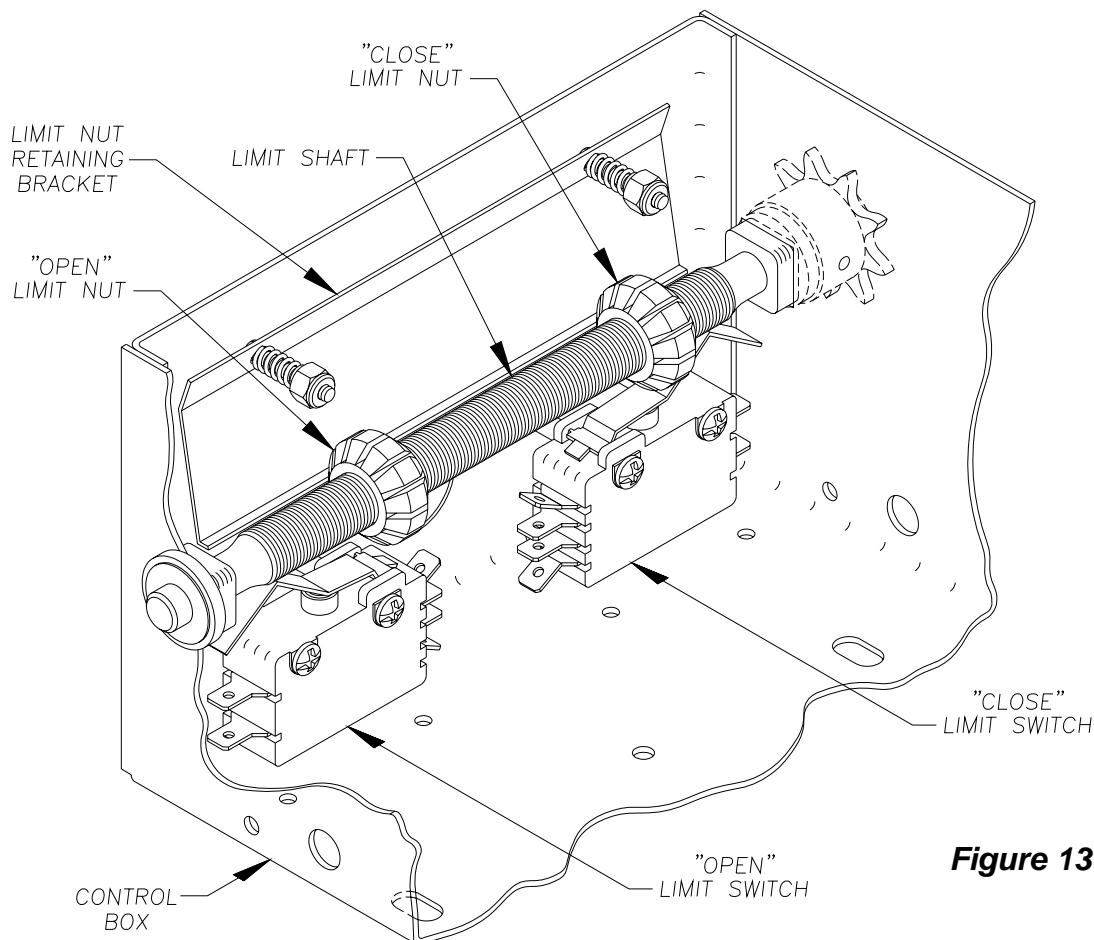

**Figure 13**



## WARNING

TO PREVENT THE RISK OF PERSONAL INJURY OR DEATH :

- DISCONNECT POWER AT THE FUSE BOX BEFORE PROCEEDING.
- ELECTRICAL CONNECTIONS MUST BE MADE BY A QUALIFIED INDIVIDUAL.
- OBSERVE LOCAL ELECTRICAL CODES WHEN WIRING THE OPERATOR.

**NOTE:** PowerMaster EMG operators have been designed and constructed for use with voltages from 115 Volts AC to 480 Volts AC, in single or three phase. Check the operator nameplate label on the control box cover for the proper voltage and phase. The application of an improper input voltage or phase will result in catastrophic failure to the internal electrical components. Observe local electrical codes when wiring the operator.

When hard wiring, observe state and local electrical codes. A wiring diagram is attached to the inside of the control box cover. Connect the appropriate voltage and phase power leads to the appropriate terminals as per the wiring diagram and connect a ground wire to the grounding screw. On three phase units, incorrect phasing of the power supply will cause the motor to rotate in the wrong direction (open when CLOSE button is pushed and vice versa). To correct this, interchange any two of the incoming three phase conductors.

The wiring diagram attached inside the cover of the control box details all of the field wiring terminal connections for the operator. Always connect the wires to the push-button controls and auxiliary devices exactly as shown.

**Warning:** Control voltage of the operator is 24 volts AC, Class 2. Do not run the power leads and control circuit wiring in the same electrical conduit.



## WARNING

TO PREVENT THE RISK OF PERSONAL INJURY AND/OR DAMAGE TO DOOR OR PROPERTY, ONLY OPERATE DOOR CONTROL WHEN DOOR IS IN CLEAR VIEW. IF CONTROL STATION CANNOT BE LOCATED WHERE THE DOOR IS VISIBLE OR IF ANY OTHER DEVICE IS USED TO CONTROL THE DOOR AN AUXILIARY ENTRAPMENT DEVICE (DOOR EDGE OR PHOTOELECTRIC) *MUST BE CONNECTED.*



## WARNING

RISK OF ENTRAPMENT THAT MAY RESULT IN SERIOUS PERSONAL INJURY OR DEATH. DISCONNECT POWER TO THE OPENER BEFORE AND DURING INSTALLATION OF AN ACCESSORY REVERSING DOOR EDGE OR PHOTOELECTRIC DEVICE. DO NOT RECONNECT POWER TO OPENER UNTIL INSTRUCTED TO DO SO. ENSURE DOORWAY IS CLEAR BEFORE STARTING TESTING OF UNIT.

**Note:** EMG operators are pre-wired to accept reversing edge components. To comply with UL requirements, one of these systems must be installed and wired to the operator. Refer to Figures 16 and 17 for Edge component wiring and installation.

For operator models not installed with reversing edge components or photoelectric device, ONLY ONE THREE BUTTON STATION OR A CONTROL WIRED FOR CONSTANT PRESSURE TO CLOSE MAY BE USED TO CONTROL THE OPERATOR. THIS IS TO COMPLY WITH UL SAFETY REQUIREMENTS. IN THIS CASE THE CONTROL STATION MUST BE LOCATED WITHIN CLEAR SIGHT OF THE DOOR ADJACENT TO A PLACARD (SUPPLIED WITH THE OPERATOR) WITH THIS WORDING:

**WARNING TO PREVENT ENTRAPMENT  
DO NOT START DOOR DOWNWARD  
UNLESS DOOR WAY IS CLEAR**

Operators which are equipped with a reversing edge circuit may have one or more additional means of control which should be wired in accordance with the diagram supplied in the operator. Refer to Figure 17.

Number 18 gauge wire or heavier must be used for wiring the control stations and auxiliary control devices to the operator. Smaller gauge wire will cause operational problems, especially when multiple push-button stations are used or during summer months.



## CAUTION

TO AVOID DAMAGE TO DOOR AND OPERATOR ENSURE ALL DOOR LOCKS ARE DISABLED. USE AN INTERLOCK SWITCH IF A LOCK IS REQUIRED TO RETAIN FUNCTIONALTY.

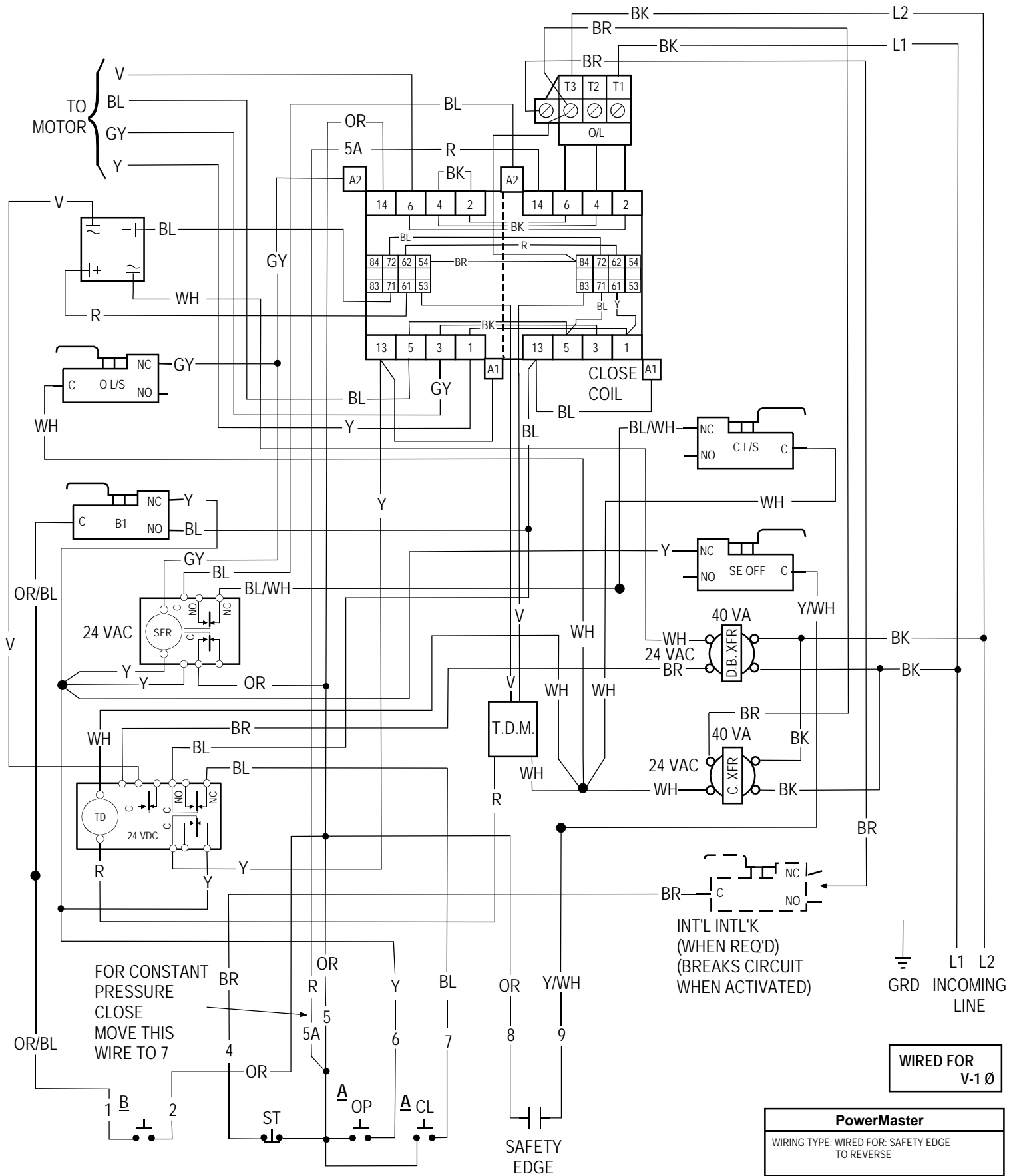

**A** TREADLES, PULL SWITCHES, KEY SWITCHES, WANDS, PHOTOELECTRIC DEVICES, ETC. MAY BE CONNECTED WHERE INDICATED.

**B** PULL SWITCHES AND SINGLE CONTACT CONTROL STATIONS MAY BE CONNECTED TO TERMINALS INDICATED.

<b>PowerMaster</b>	
WIRING TYPE: WIRED FOR SAFETY EDGE TO REVERSE	
DATE: 1-6-99	REV. 13
BY: F.S.	
SPECIAL: DYNAMIC BRAKING	
WIRING DIAGRAM NO. EX-31	
© Copyright PowerMaster 1997 No portion of this diagram may be reproduced without the expressed written permission of the manufacturer.	

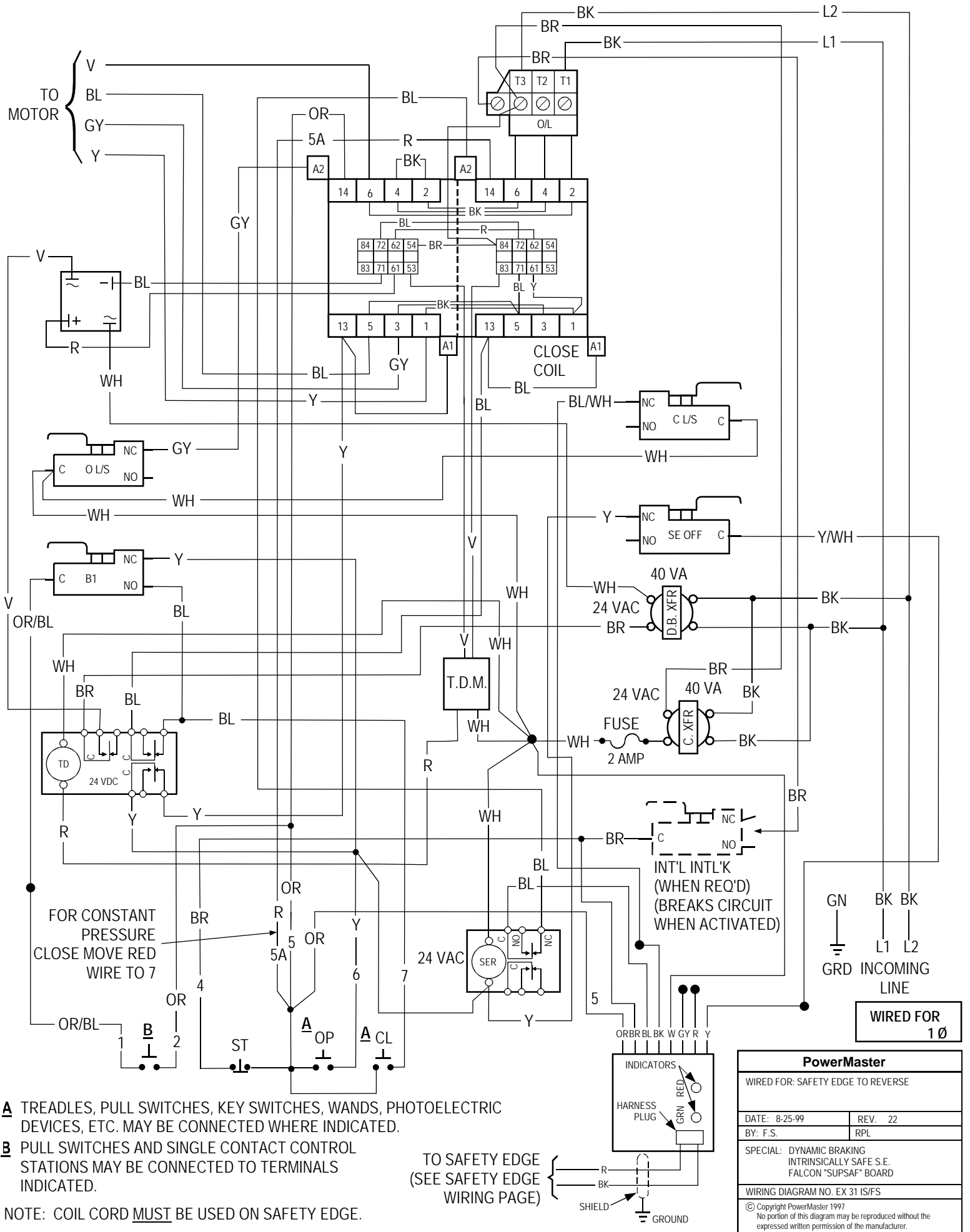

**A** TREADLES, PULL SWITCHES, KEY SWITCHES, WANDS, PHOTOELECTRIC DEVICES, ETC. MAY BE CONNECTED WHERE INDICATED.

**B** PULL SWITCHES AND SINGLE CONTACT CONTROL STATIONS MAY BE CONNECTED TO TERMINALS INDICATED.

NOTE: COIL CORD MUST BE USED ON SAFETY EDGE.

<b>PowerMaster</b>	
WIRED FOR: SAFETY EDGE TO REVERSE	
DATE: 8-25-99	REV. 22
BY: F.S.	RPL
SPECIAL: DYNAMIC BRAKING INTRINSICALLY SAFE S.E. FALCON "SUPSAF" BOARD	
WIRING DIAGRAM NO. EX 31 IS/FS	
© Copyright PowerMaster 1997 No portion of this diagram may be reproduced without the expressed written permission of the manufacturer.	

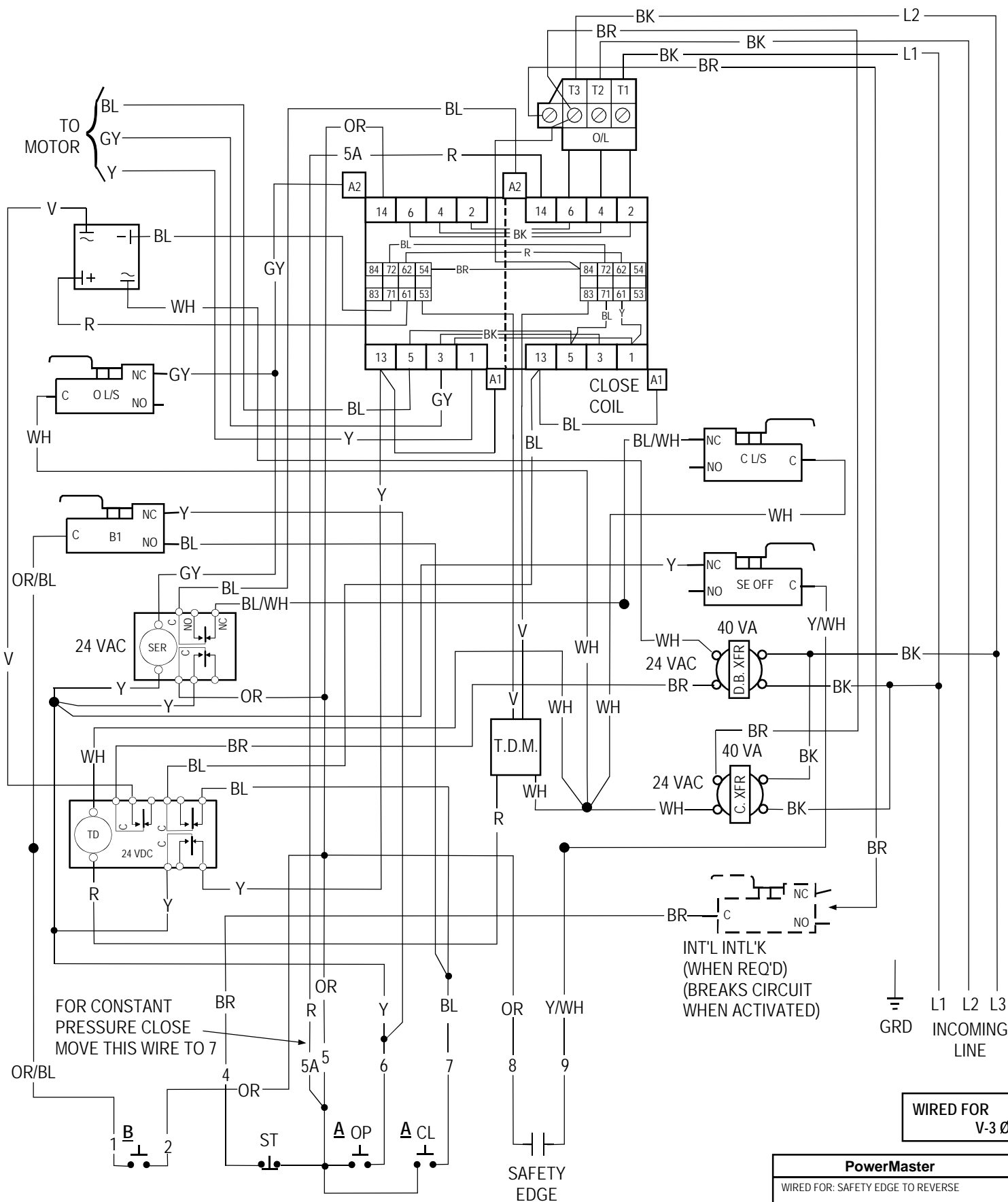

**WIRED FOR**  
V-3Ø

**A** TREADLES, PULL SWITCHES, KEY SWITCHES, WANDS, PHOTOELECTRIC DEVICES, ETC. MAY BE CONNECTED WHERE INDICATED.

**B** PULL SWITCHES AND SINGLE CONTACT CONTROL STATIONS MAY BE CONNECTED TO TERMINALS INDICATED.

PowerMaster	
WIRED FOR: SAFETY EDGE TO REVERSE	
DATE: 1-6-99	REV: 13
BY: F.S.	
SPECIAL: DYNAMIC BRAKING	
WIRING DIAGRAM NO.: EX-33	
© Copyright PowerMaster 1997 No portion of this diagram may be reproduced without the expressed written permission of the manufacturer.	



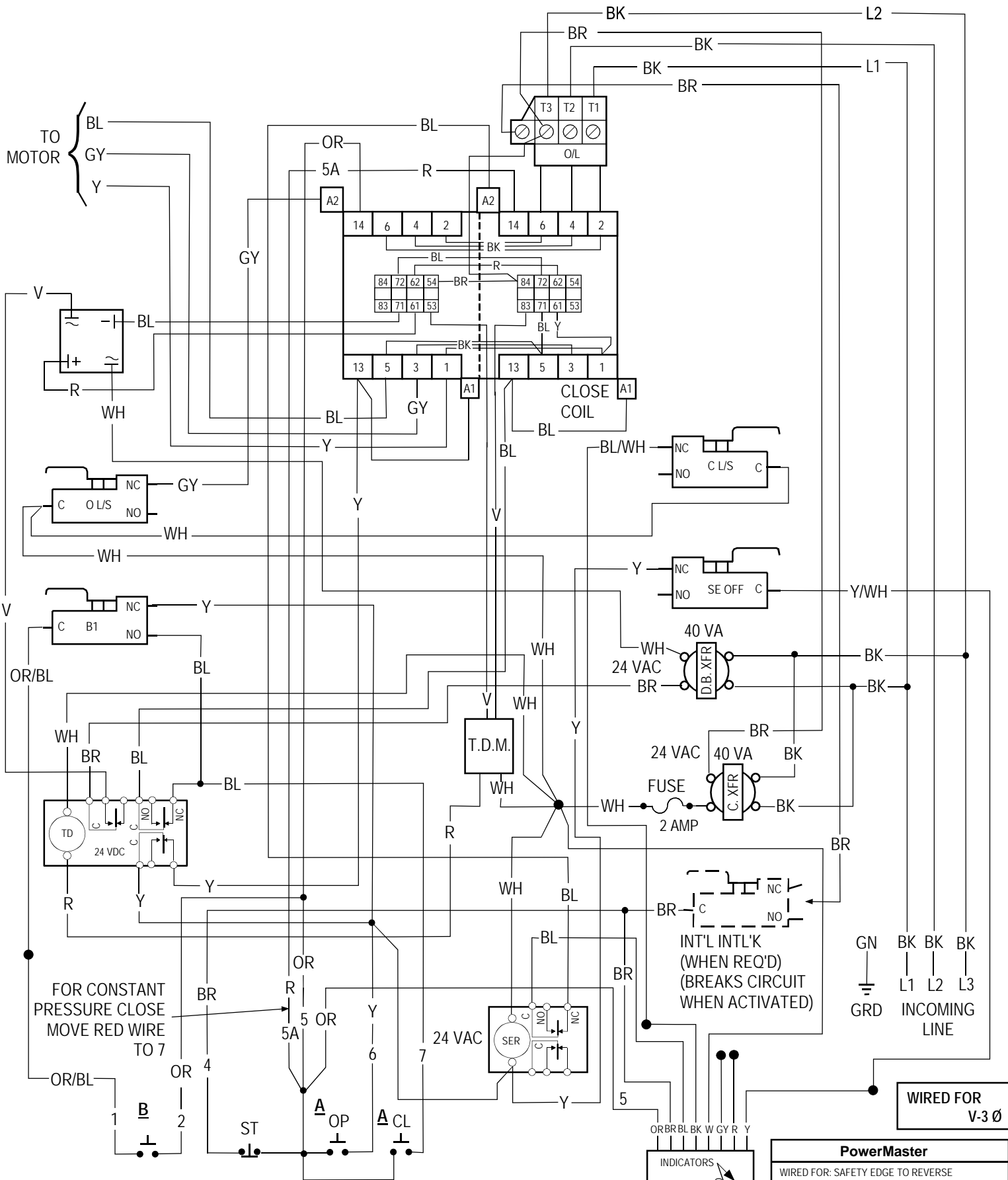

**A** TREADLES, PULL SWITCHES, KEY SWITCHES, WANDS, PHOTOELECTRIC DEVICES, ETC. MAY BE CONNECTED WHERE INDICATED.

**B** PULL SWITCHES AND SINGLE CONTACT CONTROL STATIONS MAY BE CONNECTED TO TERMINALS INDICATED.

NOTE: COIL CORD MUST BE USED ON SAFETY EDGE.

TO SAFETY EDGE  
(SEE SAFETY EDGE  
WIRING PAGE)

PowerMaster	
WIRED FOR: SAFETY EDGE TO REVERSE	
DATE: 8-25-99	REV: 22
BY: F.S.	RPL
SPECIAL: DYNAMIC BRAKING INTRINSICALLY SAFE S.E. FALCON "SUPSAF" BOARD	
WIRING DIAGRAM NO. EX 33 IS/F/S	
© Copyright PowerMaster 1997 No portion of this diagram may be reproduced without the expressed written permission of the manufacturer.	

## IMPORTANT SAFETY INSTRUCTIONS FOR OWNER



### WARNING

**TO REDUCE THE RISK OF SEVERE INJURY OR DEATH: READ AND FOLLOW ALL INSTRUCTIONS!**

- **NEVER** let children operate or play with door controls. Keep the Remote Control away from children.
- **ALWAYS** keep a moving door in sight and keep people and objects away from the door area until the door is completely closed. **NO ONE SHOULD CROSS THE PATH OF A MOVING DOOR.**
- **TEST THE DOOR OPENER'S REVERSING FEATURE** (where applicable) **MONTHLY**. The door **MUST** reverse upon contact with a 4" high object on the floor.
- After adjusting the force setting, if equipped with a clutch, or the limit of travel, **ALWAYS RETEST** the Opener. **Failure to ADJUST THE OPENER PROPERLY may result in SERIOUS INJURY OR DEATH.**
- **DO NOT** over adjust the force setting (clutch, where applicable) to compensate for a poorly working door. See page 19 for procedure to check the door operation and insert sheet for proper clutch adjustment.
- **KEEP THE GARAGE DOOR PROPERLY BALANCED.** (See the door owner's manual.)
- **AN IMPROPERLY BALANCED DOOR MAY CAUSE SEVERE INJURY OR DEATH.**
- Have a **QUALIFIED SERVICE PERSON MAKE REPAIRS TO CABLES, SPRING ASSEMBLIES AND OTHER HARDWARE.**
- **SAVE THIS INSTRUCTION MANUAL AND GIVE TO THE END USER.**

**NOTE:** It is now necessary to turn on the power in order to run the Opener to check for proper operation and limit settings. Before doing so, ensure that all mounting hardware are installed and properly tightened, that all electrical connections are per local code requirements, and that proper wiring practices have been followed. **Also, double-check that all ropes have been removed from the door and that the doorway is clear.**

## WIRING TERMS



### WARNING

**FAILURE TO TEST REVERSING SYSTEM COULD RESULT IN DEATH OR SERIOUS INJURY. TEST THIS SYSTEM ONCE A MONTH.**

**MOMENTARY CONTACT:** Button can be pushed and then released and door will keep moving or stop without maintaining pressure on the button.

**CONSTANT PRESSURE:** Constant pressure is required on the button in order for continued door movement. When the button is released the door will stop and possibly reverse to full open depending on wiring type.



### WARNING

**AVOID ELECTROCUTION:  
DO NOT ROUTE LOW VOLTAGE WIRES IN SAME CONDUIT AS HIGH VOLTAGE WIRES.  
FOLLOW ALL LOCAL ELECTRICAL CODES or  
THE NATIONAL ELECTRICAL CODE (NEC).**

**DOOR EDGE/PHOTOELECTRIC INPUT:** The operator wiring provides for input from an optional pneumatic or electric door bottom edge or photoelectric device that will cause a closing door to stop and may reverse it to open depending on the wiring type.

## TESTING

**WARNING**

**ALWAYS DISCONNECT POWER TO THE OPERATOR BEFORE SERVICING, CONNECTING ACCESSORY DEVICES OR MAKING ADJUSTMENTS.**

Following installation, the operator **MUST** be tested and respond correctly to all controls as specified on the wiring diagram. **KEEP** personnel and equipment clear of the area beneath the door when performing the tests. When testing the 3-button wall station, first observe that each button operates the door in the direction indicated and that the **STOP** button performs that function. With the door stopped at its full open position, the **OPEN** button should be inoperative. This should be verified and, likewise, the **CLOSE** button should be inoperative with the door fully closed.

Certain operator control circuits use only a single button or a two button control station and may be designed to function differently than the more common three-button circuit described above. Test the controls in accordance with the proper response for your installation.

Observe the door when traveling in each direction for smoothness of operation. Test the setting of the clutch (if equipped) by restraining the door by hand. The clutch should slip. Re-check the limit settings. The door should close tightly at the floor without excessive impact. Likewise, it should fully clear the door opening without the carrier striking the stops on the rail.

MG operators are equipped with a reversing edge circuit for use with pneumatic edge or foam edge door components.

**WARNING**

**DO NOT STAND UNDER DOOR TO TEST REVERSING EDGE. USE A CORRUGATED BOX OR SIMILAR OBJECT.**

To test it for proper reversal, place an object beneath the leading edge of the door. The door should instantly reverse when it comes into contact with the object provided the height of the object exceeds the cut out point built into the close limit switch (approximately four inches).

If the operator is equipped with other means of control, such as additional 3 button stations or radio controls, each of these should be tested separately for proper operation.

To test the manual disconnect first move the door to the fully closed position. Then disconnect the power to the operator. Manual door operation mode should engage when the release chain is pulled. The door can then be manually opened or closed by physically moving the door or using the hoist chain. If it is difficult to engage and/or the jackshaft to doorshaft chain appears to be under compression, reset the **CLOSE** limit slightly to reduce the door travel in the close direction.

Normally, very little maintenance is required. A monthly visual inspection must be made for loose or missing hardware and for excessive slack in the jackshaft chain. The brake is adjusted at the factory and will need periodic adjustment for wear.

Test the reversing edge circuit or components (where applicable) at least once a month by permitting the door to contact an obstruction while closing.

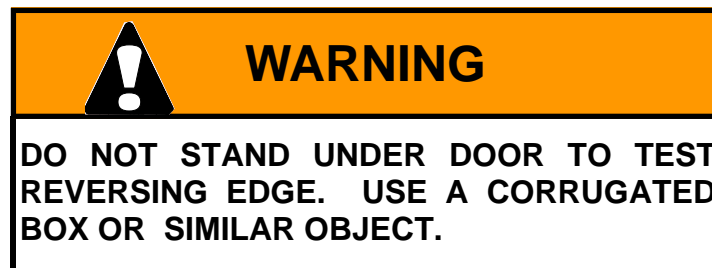

Periodic inspection of gear box oil level should be made by removing oil level plug. If oil level is below this plug, add Mobil 1 Gear Oil or equivalent to bring to proper level.

Lubrication of the operator is not required. It is important, for trouble free service from the operator, that the door be kept free from binding, properly counter balanced and periodically lubricated. **An annual inspection of the door by a qualified overhead door professional is recommended.**

\* Door must be in good operating condition. An electrical door operator cannot move a garage door that is in poor condition. The door must operate freely in the track, with no binding or obstructions, and must be well balanced. Check the spring balance of your door by bringing the door to a half-open position and leaving it there. If the door stays in that position, it is well balanced. If it moves more than a few inches the springs possibly need adjustment. Call a qualified door service company.

**Warning: Repairs and adjustments to the door and operator should be performed only by someone qualified to service commercial overhead doors and operators.**

<u>SYMPTOM</u>	<u>POSSIBLE CAUSE</u>	<u>SOLUTION</u>
Motor runs but door does not move	Door jammed or obstructed.	Check manual operation of door.
	Sprocket key missing or	Check drive chain for operation.
Limit switches do not hold setting	Drive chain too loose; permits chain to jump teeth	Adjust chain to proper tension. See Figure 7.
	Limit nuts binding on screw, causing them to jump	Check for free rotation on limit screw. Lubricate screw or replace nuts if threads are defective.
	Limit nut retaining bracket not engaging notches in nuts.	Set nuts and be sure bracket is in notch on each nut. (See Figure 13.
Door drifts when operator shuts off.	Inoperative or improperly adjusted brake.	
	Door tension incorrect.	Disconnect operator and check operation of door.
Motor hums — does not run.	Dead phase (on 3 phase).	Check power supply.
	Brake does not release.	Check wires to brake solenoid, check adjustment.
	*Door locked or jammed.	Check door. Try manual operation.
Motor does not run when open or close wall button is pressed.	Building fuse blown or circuit breaker tripped.	Check power supply fuses, circuit breakers, disconnect switch, check for cause.
	Overload protector tripped.	Reset and check for cause.
	NOTE: To isolate cause, operate contactor solenoid plunger manually. If motor runs, cause is in push button circuit.	Check pushbutton circuits for voltage against voltage indicated on wiring diagram. Check push button wiring. Check interlock switch wiring.
	Interlock switch broken or inoperative.	Check that brake release pin is making contact with interlock switch located inside chassis box. Check wiring to switch and switch function. Normally closed for operation electrically and normally open for hand chain operation.
Operator closes door when "open" button is pressed, and limit switches do not function properly.	On three phase operators power supply is connected out of phase.	Interchange connections of any two power supply leads. (See wiring diagram)
	Operator not installed correctly.	Remount operator so that motor is "up" or toward door wall or contact factory as to wiring changes required.
Operator fails to shut off at fully open closed position.	On three phase operators power supply is connected out of phase.	Check phase as above.
	Limit nuts not adjusted	See limit adjustments page 10.
	Defective limit switch.	Operator limit switch manually while door is moving to determine if switch is operative.
	Single phase operator (without instant reverse motor). Stuck push button or short in control wiring.	If door overrides up limit, check down button and circuit. If door overrides down limit, check open button and circuit.
	Limit drive chain broken or inoperative.	Replace chain, check limit screw for rotating.

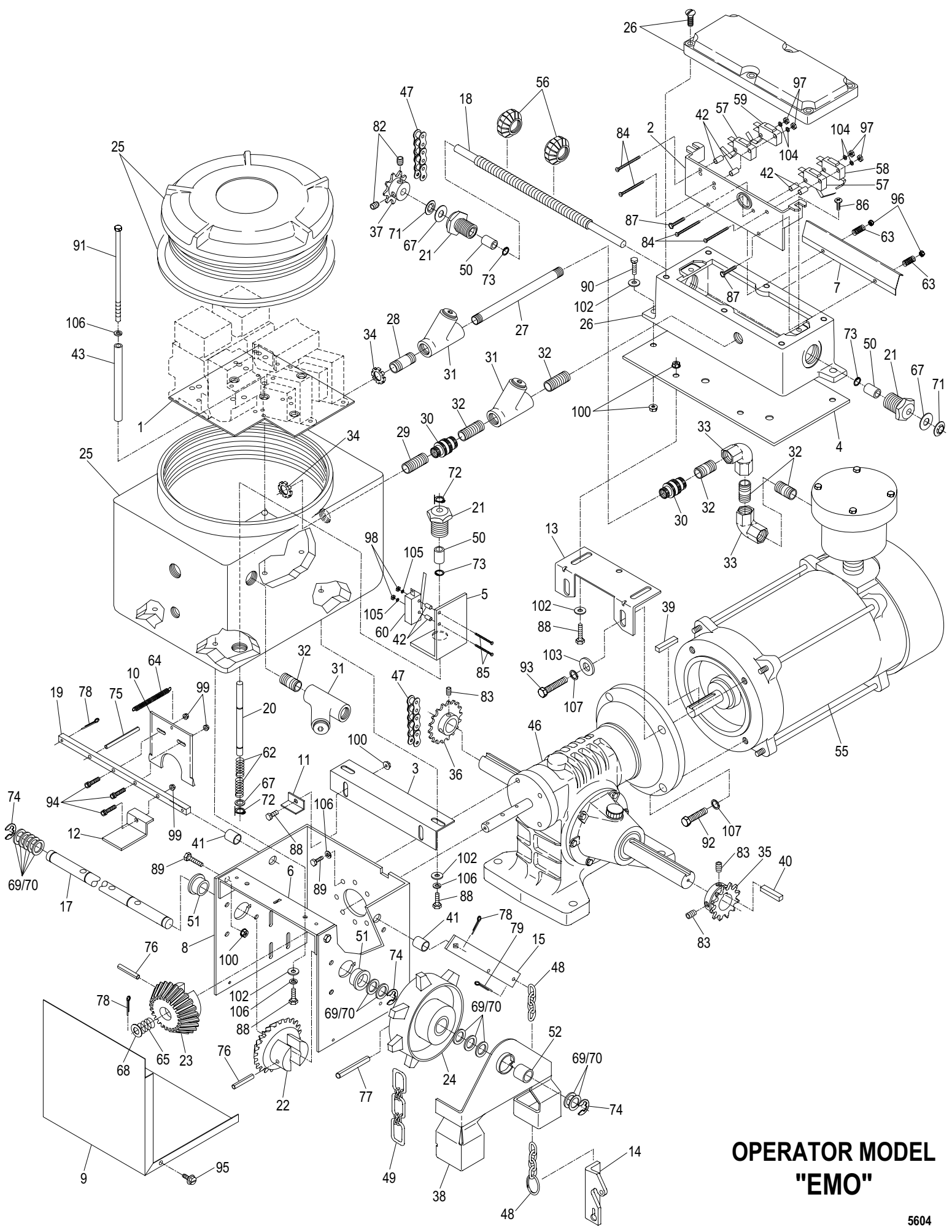

**OPERATOR MODEL  
"EMO"**



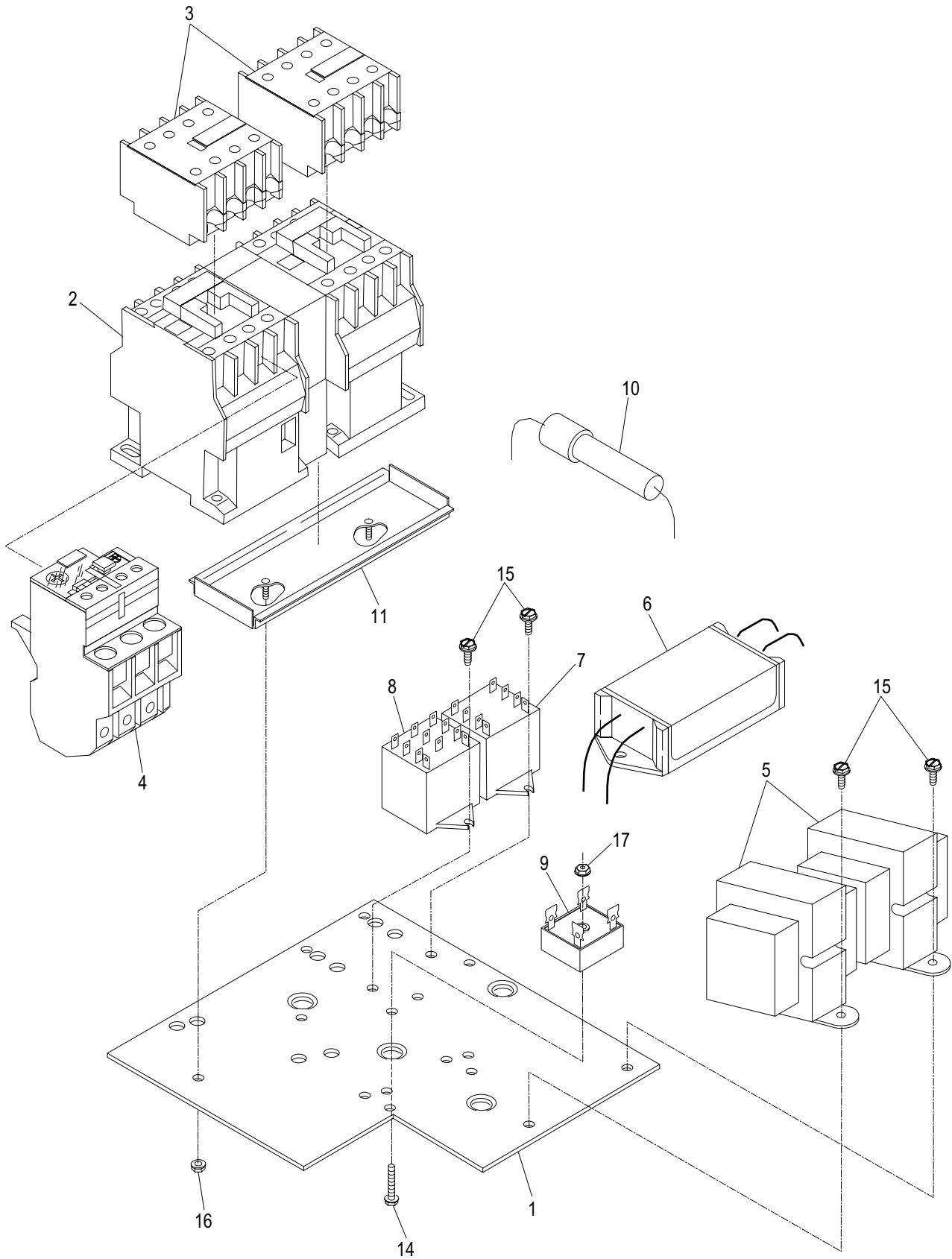

## EXPLOSION PROOF ELECTRIC PLATE ASSEMBLY

ITEM	QTY.	DESCRIPTION	PARTS #	LIST PRICE
1	One	Electrical chassis	6705	
2	One	Limit switch chassis	6706	
3	One	Electric box mounting angle	6703	
4	One	Limit box mounting plate	6704	
5	One	Interlock switch bracket	6707	
6	One	Spreader bracket	EP-003	
7	One	Limit nut retainer plate	6209	
8	One	Emergency machinery box (chassis box)	M-1002	
9	One	Emergency machinery box cover (chassis box cover)	M-1004	
10	One	Gear engagement plate (horseshoe)	M-1009	
11	One	Interlock stop bracket	6709	
12	One	Interlock switch paddle	6708	
13	One	Universal mounting bracket	2337	
14	One	Chain lock bracket	6409	
15	One	Disconnect lever	M-1000	
16				
17	One	Secondary shaft	MO-1016	
18	One	EX limit shaft	1014-1125	
19	One	Disconnect (square) shaft	WM-1015	
20	One	EX switch rod	EMO-103	
21	Three	EX fitting	EMO-101	
22	One	Miter gear without bushing	M-1011	
23	One	Miter gear with bearing	M-1013	
24	One	Chain wheel	M-104	
25	One	EMO electric box (GRL) with cover	6108	
26	One	EXP. limit switch box with cover	EP-007	
27	One	Extension pipe	EMO-AS REQ'D.	
28	One	Linear adjustment pipe	EP-3625	
29	One	EXP. nipple	6702	
30	Two	Union	GUT-1	
31	Three	Sealing fitting	EY-1	
32	Six	1/2" Close pipe nipple	78-0401	
33	Two	90° Elbow	FF-90-1	
34	Two	1/2" Conduit lock nut	151	
35	One	Drive sprocket	7311	
36	One	Limit drive sprocket	7339	
37	One	Limit driven sprocket	1036	
38	One	Chain guard	6215	
39	One	3/16" Square key	SK316X1375	
40	One	1/4" square key	SK14X1250	
41	Two	Disconnect shaft spacer	60998	
42	Six	Limit switch spacer	60223	
43	Two	Electrical chassis standoff	EP-4625	
44				
45				

ITEM	QTY.	DESCRIPTION	PARTS #	LIST PRICE
46	One	Gear reducer (up to 1 H.P.)	VE-55	
		or Gear reducer (1-1/2-2 H.P.)	VE-70	
47	One	Limit roller chain (for 55 reducer)	RC65X49	
		or Limit roller chain (for 70 reducer)	RC65X51	
48	One	Disconnect chain	8A-12	
49	One	Emergency hand chain	LL-40	
50	Three	Oilite bearing	AA-6307	
51	Two	3/4" flange bearing	FB-750	
52	One	3/4" Plain bearing	PB-750	
53				
54				
55	One	Motor	AS REQ'D.	
56	Two	Limit nut	L-100	
57	Two	Limit switch	D44-8	
58	One	Limit switch	D44-17	
59	One	Limit switch	D44-19	
60	One	Interlock switch	IS-MG	
61				
62	Two	Interlock plunger compression spring	LE37C1MW	
63	Two	Limit nut guide pressure spring	LC45D3MW	
64	One	Horse shoe return spring	LE049C09MW	
65	One	Miter gear return spring	LC067K4MW	
66				
67	Three	3/8" Shim	375X050	
68	One	5/8" Shim	625X050	
69	As Req.	3/4" Shim (thin)	750X016	
70	As Req.	3/4" Shim (thick)	750X050	
71	Two	3/8" Push-on retaining ring	PS375012	
72	Two	3/8" Retaining ring	1400-37	
73	Three	5/8" Retaining ring	N-1300-62	
74	Three	3/4" E-ring	SE-74-STPA	
75	One	Roll pin	R187X2.5	
76	Two	Roll pin	R312X1.625	
77	One	Roll pin	R312X2.5	
78	Three	Cotter pin	C125X1	
79	One	Cotter pin	C125X1.5	
80				
81				
82	Two	Socket set screw	1404SSC	
83	Three	Socket set screw	3105SSC	
84	Four	Pan head machine screw	0428MSP	
85	Two	Pan head machine screw	0624MSP	
86	Two	Round phillips head screw	1106MPR	
87	Two	Hex head machine screw	0616MH	
88	Eight	Hex head tap bolt	1408BHT	





# PowerMaster

## Limited 2 Year Warranty

PowerMaster warrants all door operators to be free of defects in materials and workmanship for a period of two (2) years from date of purchase. If any part is found to be defective during this period, new parts will be furnished free of charge. Failure of this product due to misuse, improper installation, alterations, vandalism, or lack of maintenance is not covered under this warranty, and voids any other implied warranties herein.

PowerMaster is not responsible for any labor charges incurred in connection with the installation of warranted parts.

**In order to activate this warranty, the registration form on opposite page MUST be completed and returned within THIRTY CALENDER DAYS FROM DATE OF PURCHASE VIA CERTIFIED MAIL, fax (631-951-3934) or via email [PMTECH@optonline.net](mailto:PMTECH@optonline.net) If registration is not activated, a one year warranty will apply.**

**Model** \_\_\_\_\_

Date Installed \_\_\_\_\_

Serial # \_\_\_\_\_

### Installer's Information

Company Name \_\_\_\_\_

Company Address \_\_\_\_\_

Company Address \_\_\_\_\_

Company Address \_\_\_\_\_

Company Telephone # \_\_\_\_\_

Company Contact \_\_\_\_\_



R&S Automation  
7200 E. 92nd Avenue  
Unit A  
Portland, OR 97266  
877-388-4001  
503-771-4685  
Fax 503-774-6708

John Greene Corp.  
2807 Center Circle Drive  
Downers Grove, IL 60515  
800-374-7890  
Fax 630-627-7995

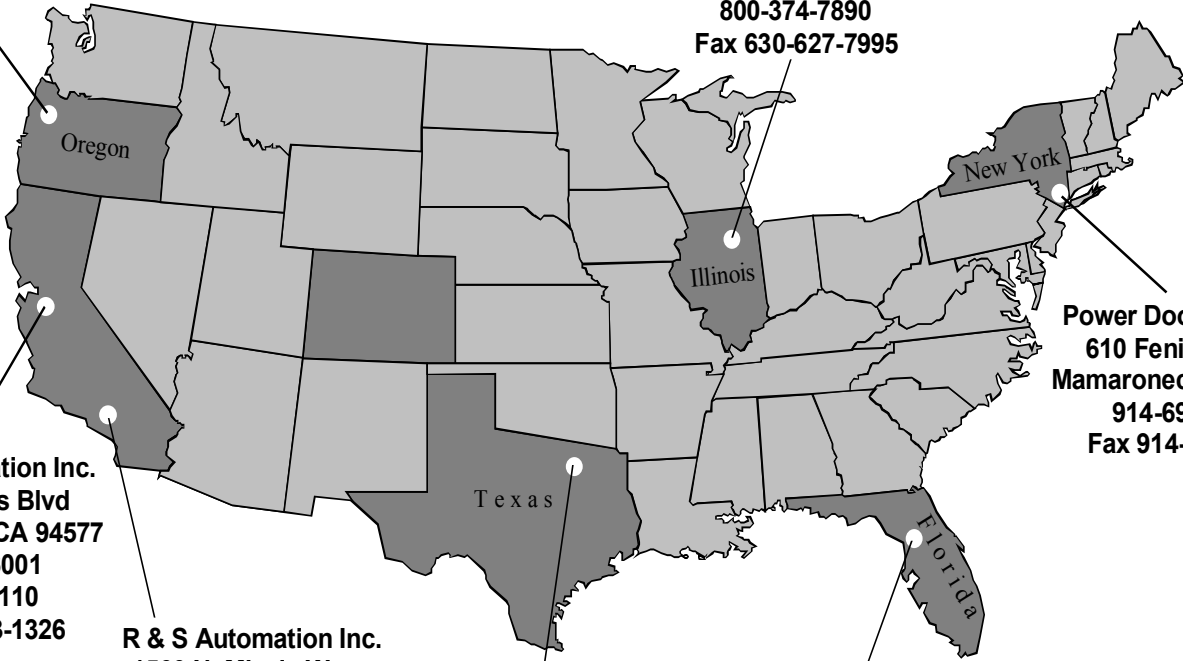

R & S Automation Inc.  
15075 Wicks Blvd  
San Leandro, CA 94577  
800-543-6001  
510-357-4110  
Fax 510-483-1326

R & S Automation Inc.  
1560 N. Missile Way  
Anaheim, CA 92801  
800-963-3111  
714-449-1645  
Fax 714-449-1679

John Greene Corp.  
3024 Avenue E. East  
Arlington, Tx 76011  
800-925-7890  
Fax 817-633-5735

John Greene Corp.  
3516 E. Norvell Bryant Hwy.  
Hernando, FL 34442  
800-323-3674  
Fax 352-726-8999

Power Door Products  
610 Fenimore Rd.  
Mamaroneck, NY 10543  
914-698-5083  
Fax 914-698-6866

Toll Free technical support @ 1-800-243-4476  
Email to [techsupport@power-master.net](mailto:techsupport@power-master.net)



**Call 1- 800 - 323 - 3674  
to order or to find a distributor near you**

**Standard Two Year Warranty**  
**Warehouses across the country w/  
factory trained managers**  
**Prompt delivery from stock**  
**Special operators normally ship  
within 7 days**

06-0922 EMG