

# powermaster

## INSTALLATION AND OWNER'S MANUAL

### MODEL ASW

### Actuator Swing Gate Operator

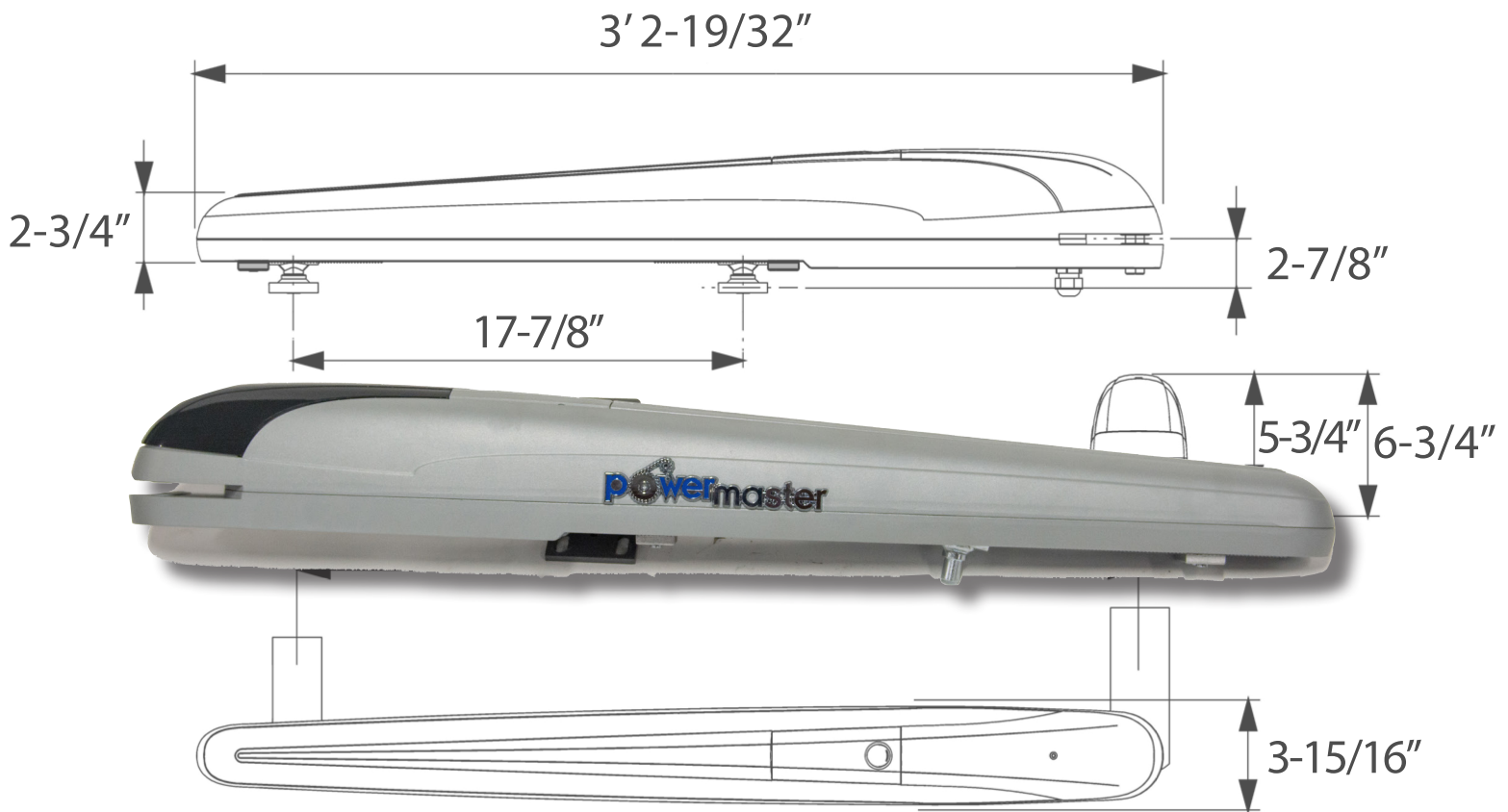

Serial #:
Date Installed:
Your Dealer:

READ THIS MANUAL CAREFULLY  
BEFORE INSTALLATION OR USE.  
SAVE THESE INSTRUCTIONS.







## IMPORTANT NOTICE FOR GATE OPERATORS MANUFACTURED AFTER JANUARY 11, 2016

All gate operators manufactured after January 11<sup>th</sup>, 2016 must have a monitored input for each direction. In order to satisfy this requirement all Powermaster Swing & Slide Gate Operators will have one monitored input for each direction: The close obstruction (C-OBS) terminal for the close direction and the open obstruction (O-OBS) terminal for the open direction. These terminals will look for, or “monitor” the presence of a 10k in-line resistor. If either terminal does not detect the presence of the monitored device the unit will function in constant contact for this direction.

E.G. The operator detects there is a monitored device on the C-OBS terminal but not the O-OBS terminal. The operator will function in momentary contact to close and constant pressure to open.

The UL 2016 devices for these units are as follows:

<b>Device</b>	<b>Manufacturer</b>	<b>Description</b>
Prime-Guard	Miller Edge	Monitored Photoeye
Reflecti-Guard	Miller Edge	Retroreflective Monitored Photoeye
IRB-MON	EMX	Monitored Photoeye
IRB-RET	EMX	Retroreflective Monitored Photoeye
The Solution	Miller Edge	Multiple Safety Devices

Any actions taken to circumvent this monitoring are in violation of the UL325, building code, and local laws.



## **WARNING** **READ CAREFULLY**



### **Important Safety Warning**

- Get professional advice.
- Gate can operate at any time with no prior warning.
- Moving gate can cause serious injury or death.
- Keep clear. Stay away from gate or operator range.
- Don't let children operate or stay close to a gate area.
- Gate operator systems are for vehicle access only.
- Provide a separate access for pedestrians.
- Never cross the gate way.
- Do not interfere with the pathway of the gate.
- Keep controls and command devices away from children's reach and from unauthorized people, and 10ft away from the gate.
- Have at least 2 visible warning signs, on both sides of the gate.
- Use the system only if completely visible and with no risk to people or objects.
- Safety is a priority! It is crucial to take any possible step for including proper safety devices in every and each installation.
- Our operators are compatible with several different safety devices ( photocells, safety edges, loop detectors, etc.).
- Permanent travel stops at maximum open & close positions must be provided, along with proper fall-over protection.
- Prevent and avoid any possible pinch-point or crushing point.
- Provide a compliant main power switch.
- Be careful with hazard related to electricity.
- Get familiar with proper functioning of manual release, and use it only after complete power-off.
- Use the system if it represents no danger to people or objects.
- Arrange proper disposal of packing materials in order to avoid potential risk for children and help environment.
- Use qualified installers only to install or fix the gate, the operator and every possible safety device and accessory.
- Proper safety wear is advisable for maintenance operation.
- Make sure to have the whole system tested under any circumstance, periodically and punctually to avoid any risk.
- Improper system operation increase risk of injury and death.
- It is recommended to keep gate systems properly maintained at least monthly.
- Automatic gate systems are intended to make gate access easy, comfortable and fluent, therefore they do not solve problems due to defects, incorrect installation or maintenance.
- Take steps to get the system compliant in accordance to local code, laws and regulations.
- Advising content is not binding and may not reflect local legislation or rules.
- UL standards are considered to be a minimum amount of safety protection.
- The manufacturers of the system and its components, as well as any other business partners like importers, distributors, dealers, etc. Including branches and subsidiaries worldwide and their personnel and employees are not to be held responsible for any damage, injury or death as consequence of gate operation, function or failure.
- For safety reasons, keep this notification along with any other important literature or information about the system.
- Safety warning and general instruction must be provided to the users, entirely explained by the installer in deep detail.
- Any doubt or concern about this important warning message must be clarified prior to the installation and operation of the system.

## Introduction

- Before installing the system, read the instructions completely.
- Do not use the PowerMaster ASW for any application not listed in this manual.
- Supply the end user with instructions for using this system.

## General Information

To ensure a good operation of these automatic devices, the gate should meet the following requirements:

- Good strength and stiffness.
- Hinges should have a minimum backlash and allow for smooth and regular manual operations.
- When closed, the gate leaves should correctly overlap for their entire height.

## How to Install the Automatic System

Calculate the height of the system from the ground (It is advisable to define a position as centered as possible with respect to the main gate and in correspondence with a strong cross girder). Weld the plate **P** following measures in **Figure 1**.

With the gate closed, weld bracket **S** to a cross beam of the main gate or other element with equal strength, according to measures shown in **Figure 1**. Keep in mind that when carrying out this operation, the actuator should not be totally in a stroke end position.

Remove cover **C** by loosening screw **F**. Then fix the actuator to plate **P** by means of screw **T** and nut **D** (**Figure 2**). Lock the actuator to plate **S** by means of screw **V** and washer **R**.

The holes in the actuator (**Figures 1a & 1b**) help to keep to the optimum installation measures.

## How to Adjust the Mechanical Stoppers

The actuator is provided with adjustable mechanical stops in the opening and closing positions. The system is adjusted by suitably positioning the *Open* and *Close* mechanical locks, as shown in **Figure 3**:

1. Unlock the automatic system by using the special release lever, as shown in the instructions for the user.
2. Close the gate leaf.
3. Loosen screws **V1** and move the Close lock until it reaches pivot **P**, then tighten screws **V2**.
4. Reset the automatic operating mode. The PowerMaster ASW has two limit micro-switches fixed to the mechanical stops.
5. The micro-switches trigger slightly in advance with respect to the mechanical stop.

## Connections

1. The special plate **P** (**Figure 4**) allows for using a link for sheath or cable gland. Once the type of cable gland is applied to the plate, fix the latter to the adaptor cover by means of screws **V**.
2. Carry out the wiring by referring to the wire diagram shown in **Figure 5**.
3. It is mandatory to provide for ground by using the GND Terminal.

TECHNICAL DATA FOR POWERMASTER ASW	
Power Supply	24VDC
Absorbed Rating	120W
Absorbed Current	6.7A
Thrust	494.5 LBF
Jogging	Intensive
Protection Degree	IP44
Operating Temperature	-4°F/122°F
Door Leaf Max. Weight	1000 lbs
Useful Stroke	17-7/8"
Translation Speed	31-1/2"/MIN
Noise Level	<70 dB
Lubrication	Permanent Grease
Weight	26 lbs

**ACTUATOR MOUNTING: STANDARD SWING IN TO OPEN**

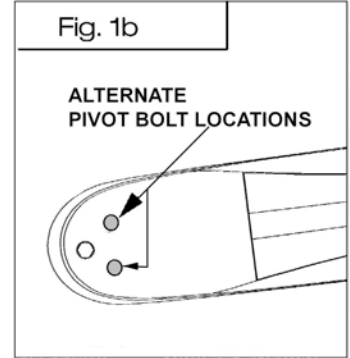
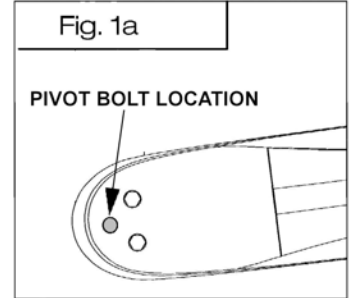
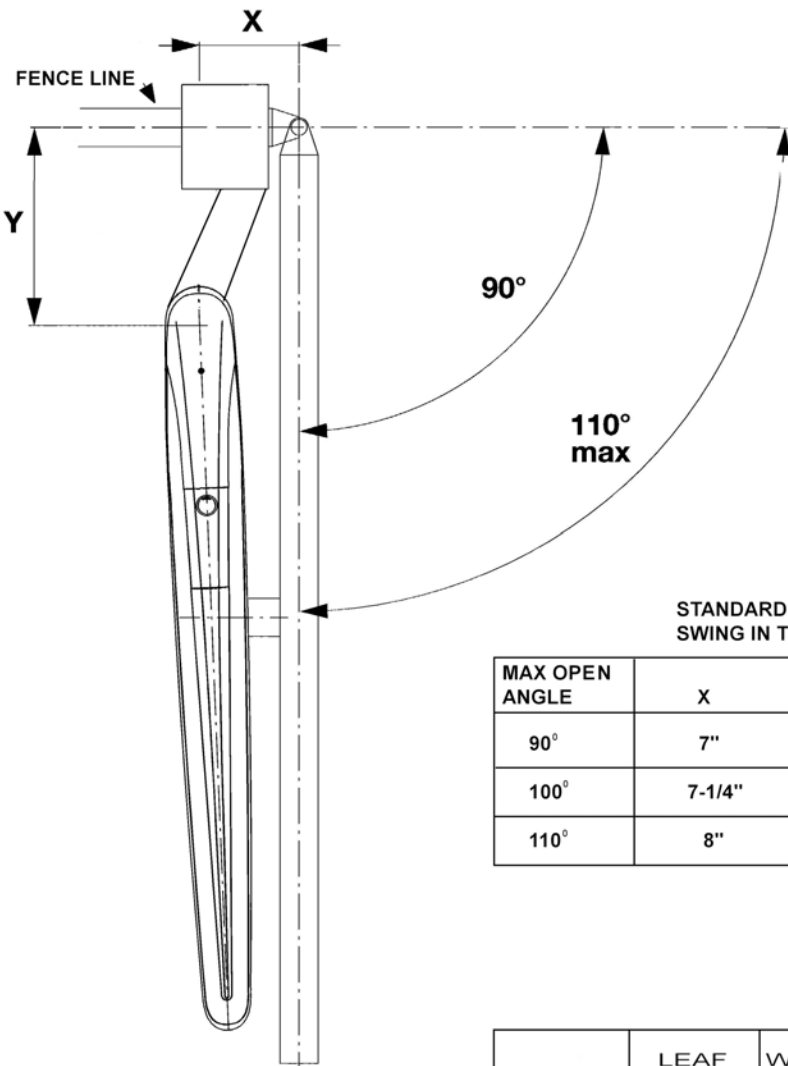
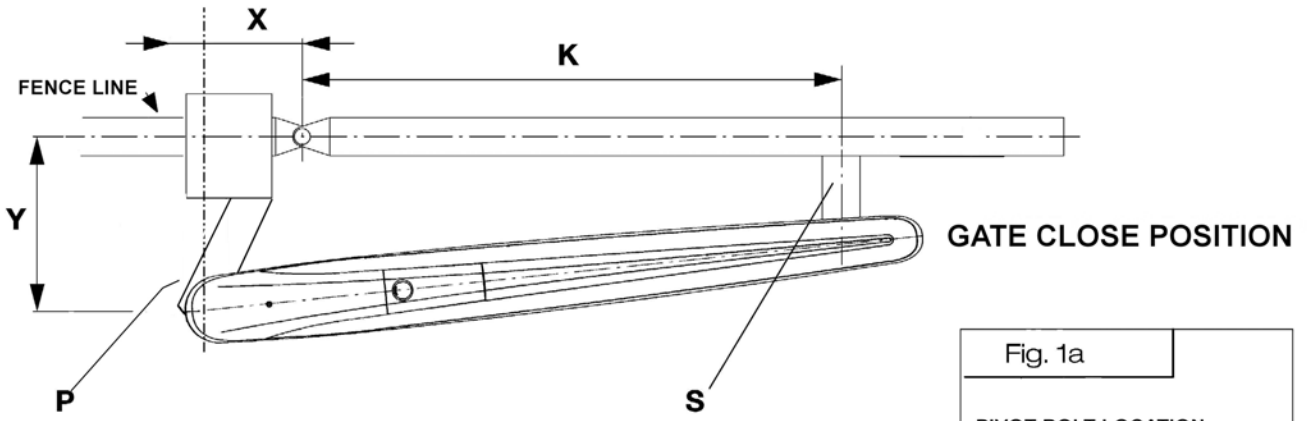

STANDARD MOUNTING  
SWING IN TO OPEN

MAX OPEN ANGLE	X	Y	K
90°	7"	7"	25-1/2"
100°	7-1/4"	7-1/4"	24-3/4"
110°	8"	8"	24"

NOTE: DIMENSIONS X, Y, & K ARE FROM CENTERLINE OF HINGE TO CENTERLINE OF PIVOT BOLTS V & T.

	LEAF	WEIGHT
MAX GATE SIZE AND WEIGHT	8'	800lbs
	10'	700lbs
	12'	600lbs
	14'	500lbs

**CAUTION:**  
FOR GATE OPERATING ANGLE GREATER THAN 90°, CAREFULLY CHECK HINGES FOR REQUIRED CLEARANCE, BEFORE MOUNTING ACTUATOR. ALLOWING GATE HINGES TO BIND WILL CAUSE DAMAGE TO THE EQUIPMENT.

**ACTUATOR MOUNTING: SWING OUT TO OPEN**

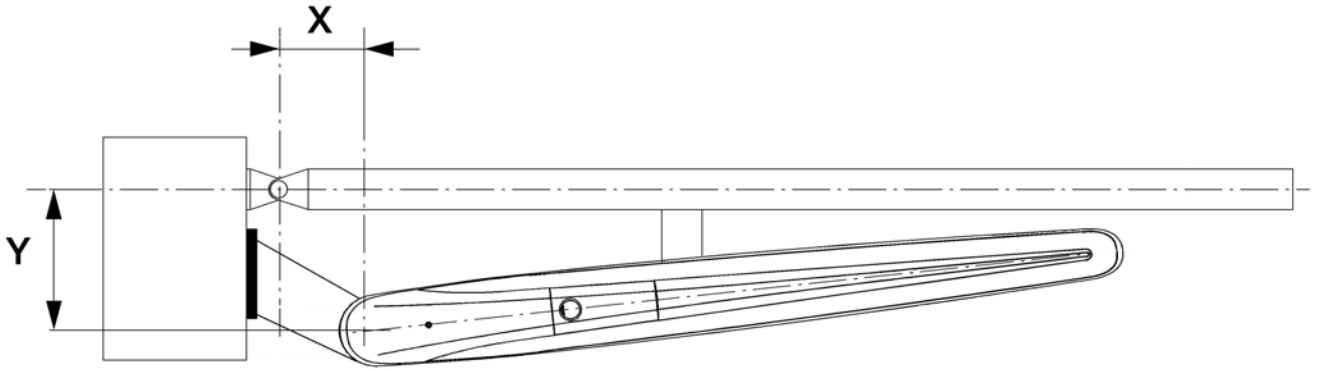

**NOTE: DEPENDING ON GATE POST, A SPECIAL BRACKET MAY NEED TO BE FABRICATED TO LOCATE THE PIVOT BOLT PROPERLY.**

**ALTERNATE MOUNTING  
SWING OUT TO OPEN  
(SEE WIRING SECTION)**

MAX OPEN ANGLE	X	Y	K
100	7"	7"	24"

MAX LEAF(FT)	MAX WEIGHT(lbs)
8'	800
10'	700
12'	600
14'	500

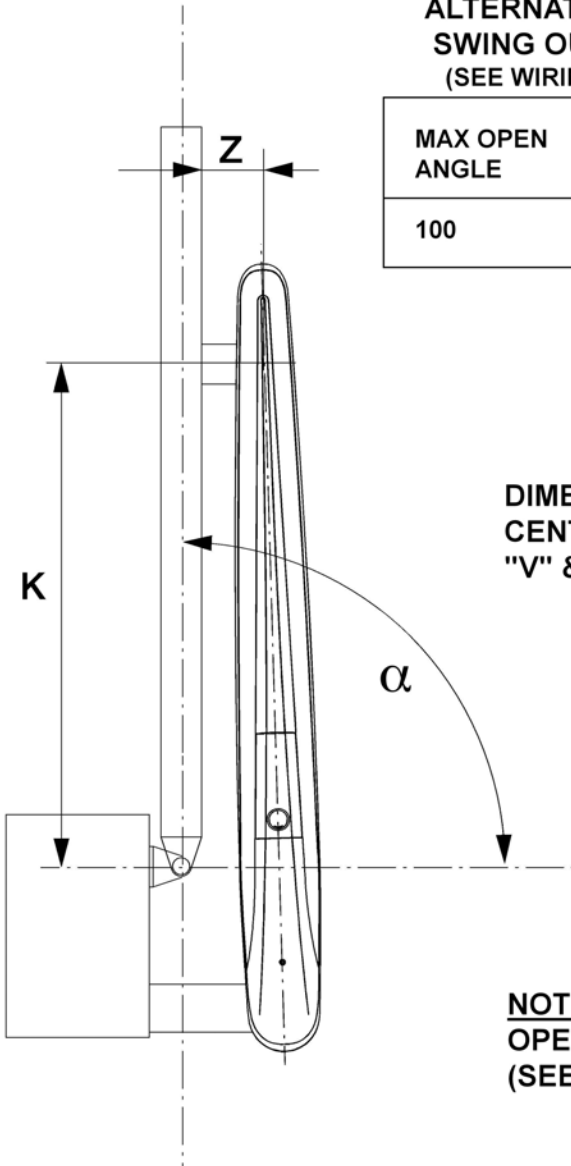

**DIMENSIONS X, Y, & K ARE FROM HINGE CENTERLINE TO CENTERLINE OF PIVOT BOLTS "V" & "T"**

**NOTE:FOR SWING OUT TO OPEN SET OPERATOR TO LEFT HAND OPERATION (Lh)  
(SEE PROGRAMMING MANUAL)**

2

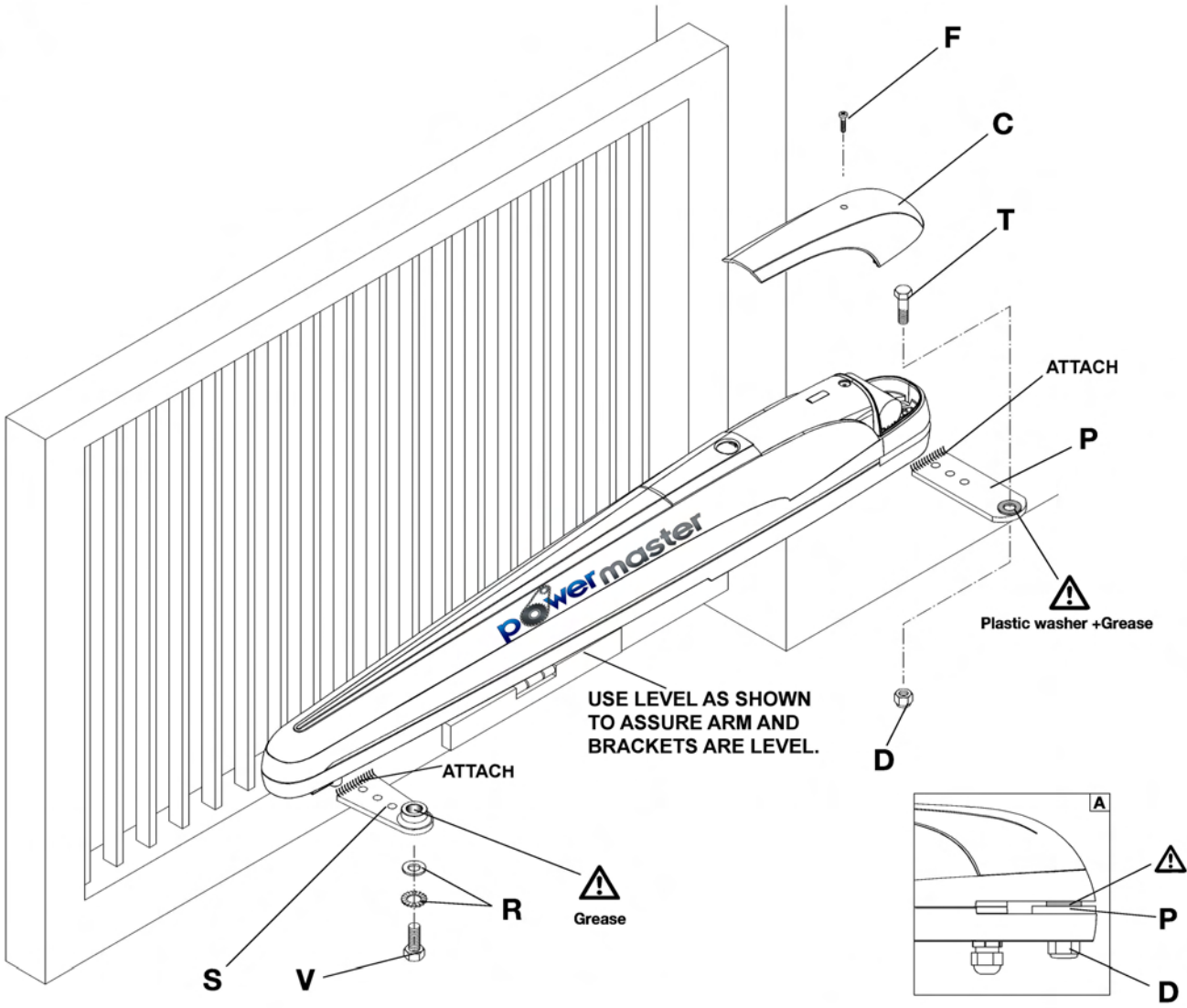

3

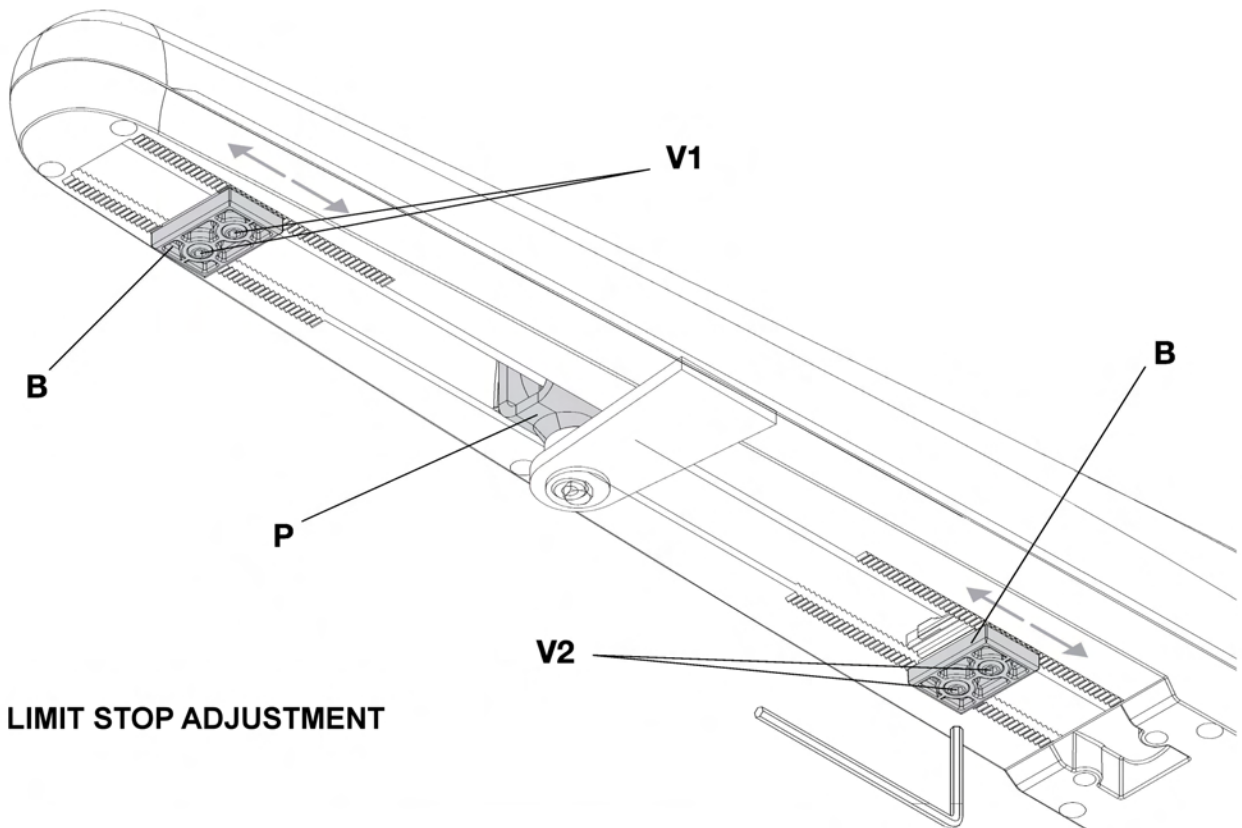

LIMIT STOP ADJUSTMENT



4

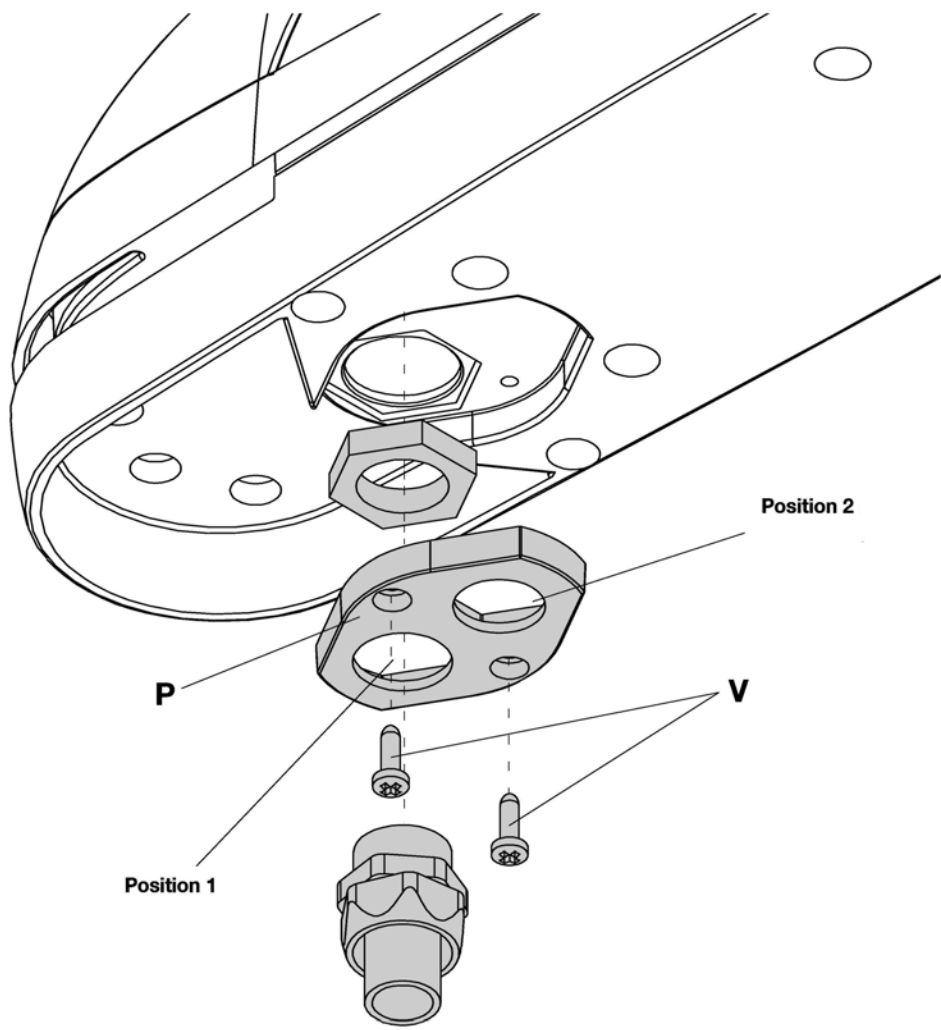

5

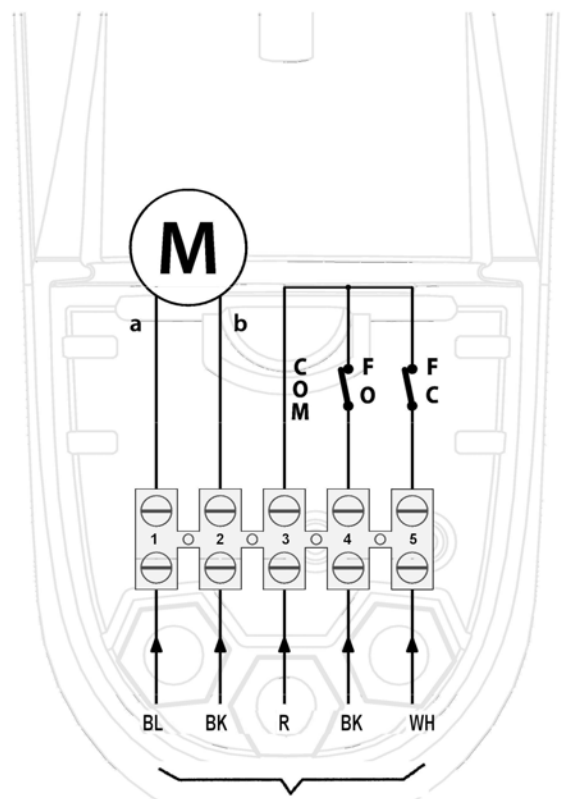

TO CONTROL BOX

\*INSIDE ACTUATOR

1	M-A	BLACK
2	M-B	RED
3	COM	GREEN
4	FO	WHITE
5	FC	BLUE

COM	COM Limit switch
FC	CLOSE Limit switch
FO	OPEN Limit switch

# WIRING LAYOUT

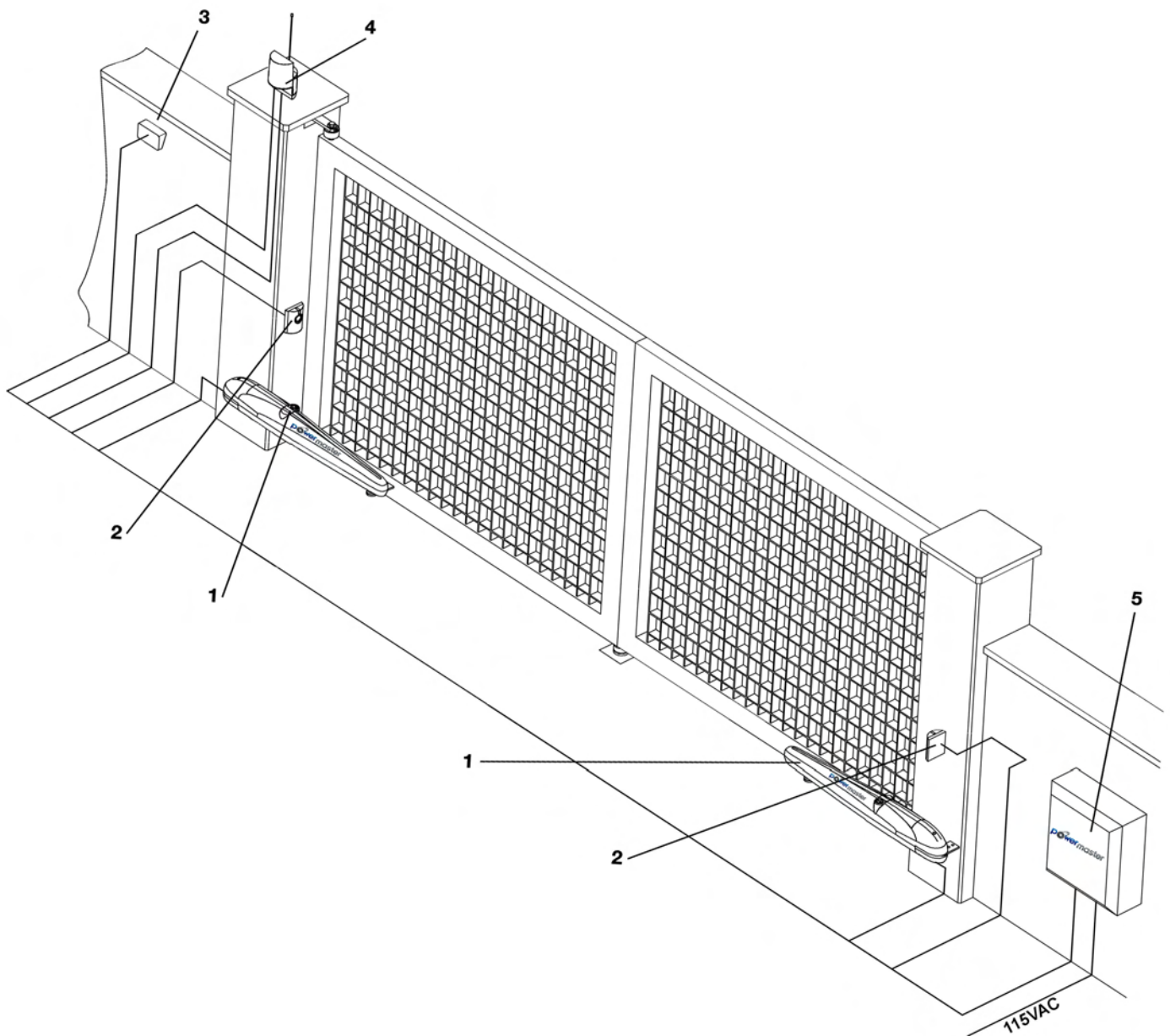

1. ASW, ACTUATOR ARM ASSEMBLY
2. PHOTO-ELECTRIC EYES
3. EXTERNAL KEYPAD
4. OPTIONAL WARNING DEVICE
5. CONTROLLER HOUSING WITH **powermaster** CONTROLLER

The power cables must be kept separated from the auxiliary cables.

# Overall dimensions

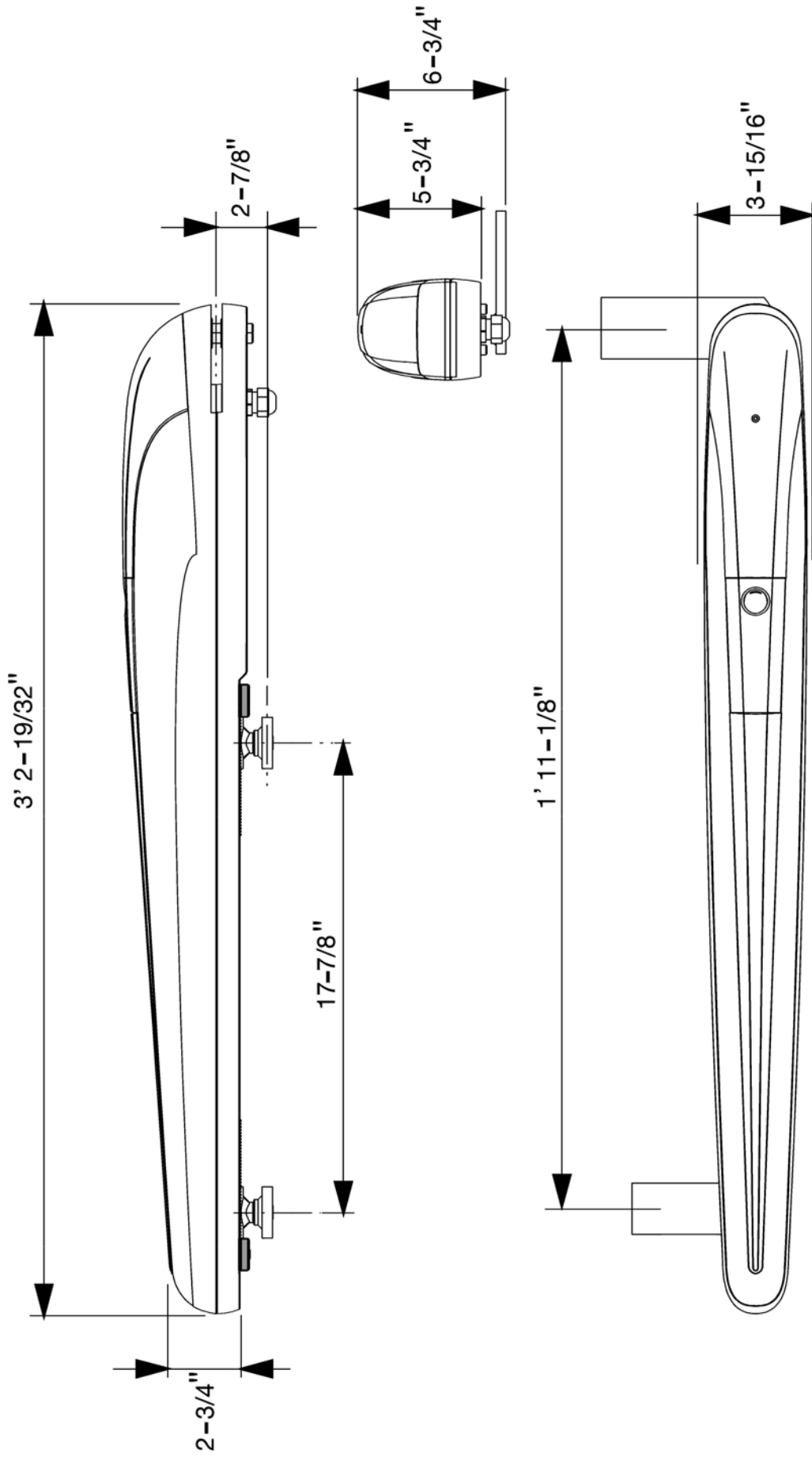

## ASW END USER GUIDE

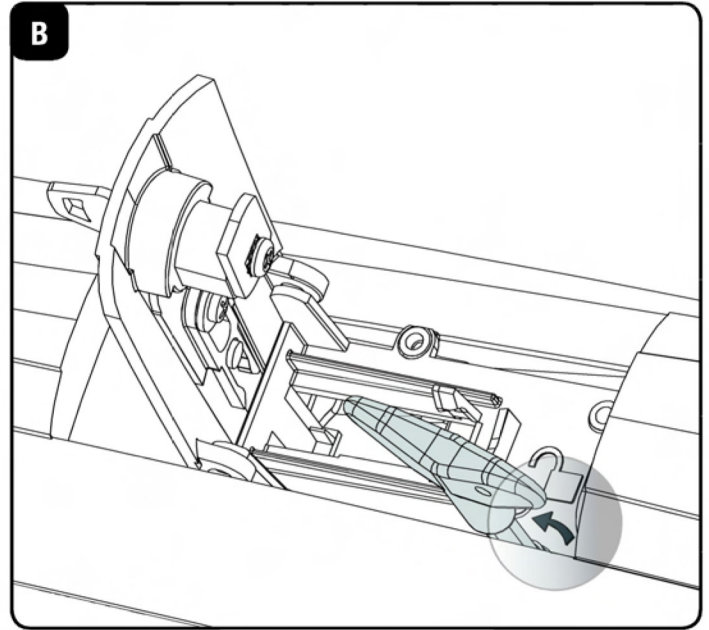
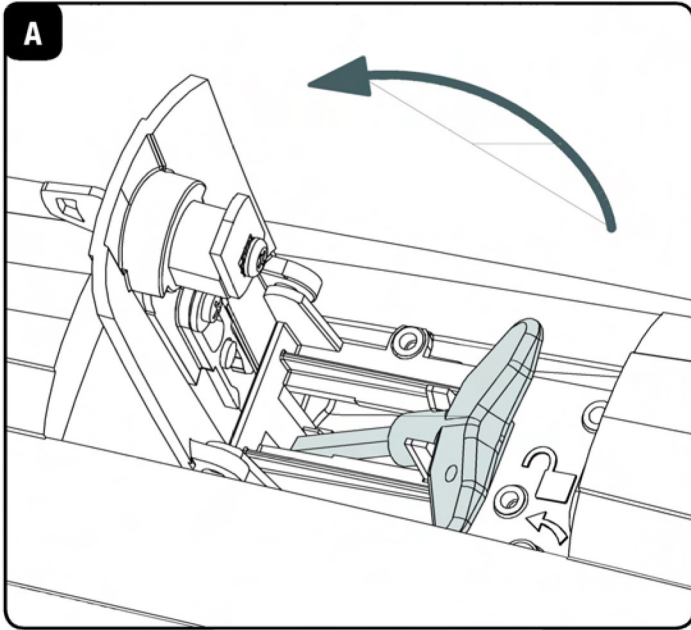

### Safety Rules

- Do not stand in the movement area of the door.
- Do not let children play with controls and near the door.
- Should operating faults occur, do not attempt to repair the fault, but call a qualified technician.

### Manual and Emergency Operation

In the event of power failure or fault, manually open and close the door/gate with the following procedure:

1. Open the protection door of the release device (Figure A).
2. Introduce the special release key supplied and turn it by 90 degrees, as shown by the arrow on the removable cover highlighted in Figure B.
3. Now the door can be opened/closed by hand.
4. To reset the automatic operation, move the release key to the initial position.
5. Remove the release lever and close the protection door.

### Maintenance

- Every month, check the good operation of the emergency manual release.
- It is mandatory not to carry out extraordinary maintenance or repairs as accidents may be caused. These operations must be carried out by qualified personnel only.
- The operator is maintenance free, but it is necessary to check periodically if the safety devices and the other components of automation system work properly. Wear and tear of some components could cause dangers.

### Waste Disposal

As indicated by the symbol shown, it is forbidden to dispose this product as normal urban waste as some parts might be harmful for environment and human health, if they are disposed of incorrectly. Therefore, the device should be disposed in special collection platforms or given back to the reseller if a new and similar device is purchased. An incorrect disposal of the device will result in fines applied to the user, as provided for by regulations in force.



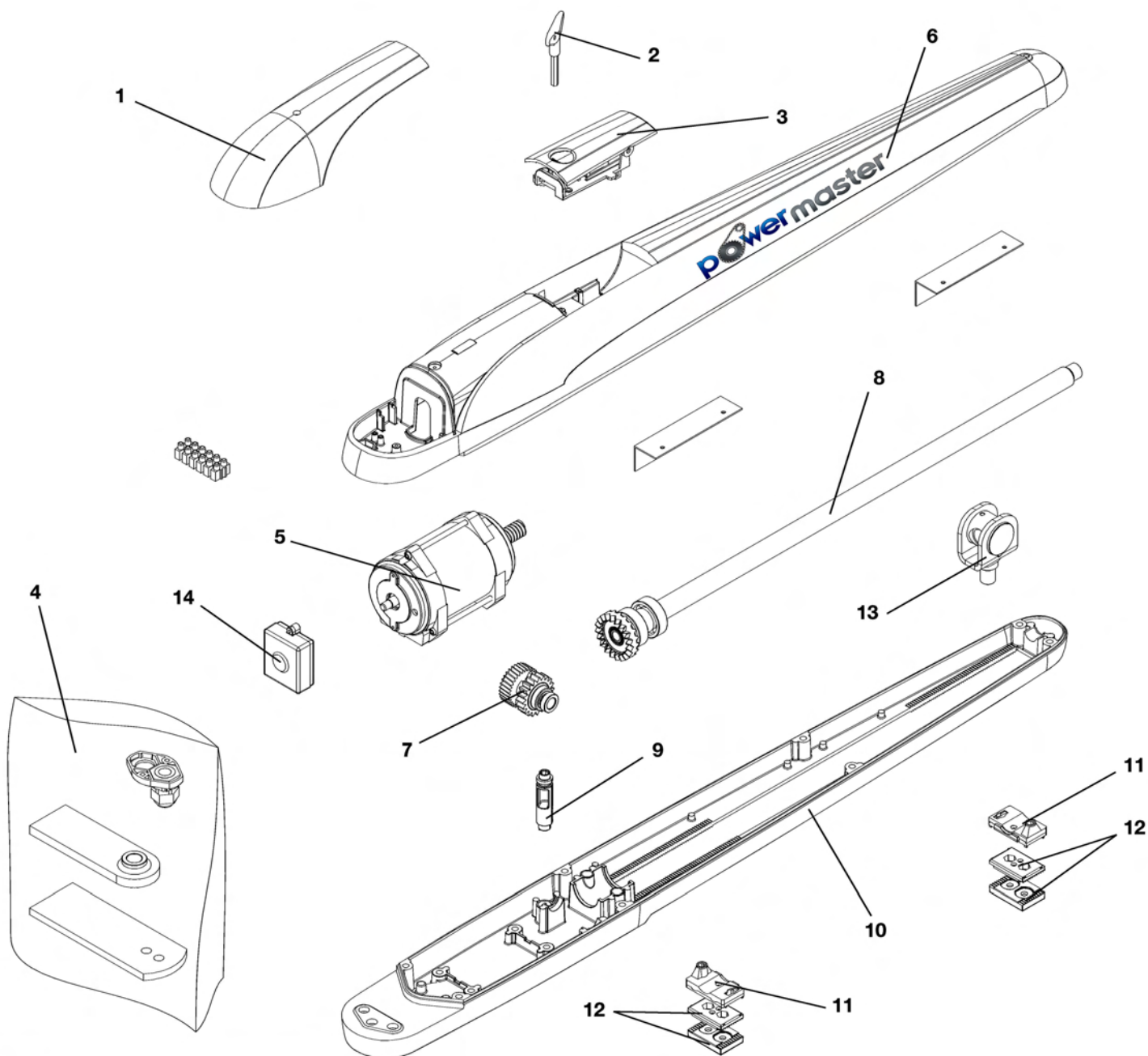

		<b>Cod.</b>
1	<b>Plastic cover</b>	9686630
2	<b>Release lever</b>	9686631
3	<b>Unblock. group</b>	9686632
4	<b>Parts bag</b>	9686633
5	<b>Motor</b>	9686643
6	<b>Upper cover</b>	9686635
7	<b>Gear</b>	9686636
8	<b>Worm screw</b>	9686637
9	<b>Lock with pin</b>	9686638
10	<b>Lower cover</b>	9686639
11	<b>Limit stop</b>	9686640
12	<b>Locks</b>	9686641
13	<b>Wormscrew supp.</b>	9686642



**TOOLS NEEDED BUT NOT INCLUDED:**

- 17mm SOCKET OR WRENCH**
- 10mm SOCKET OR WRENCH**
- 5mm ALLEN WRENCH**

# PowerMaster

## Limited 5-Year Warranty

PowerMaster warrants all gate operators to be free of defects in materials and workmanship for a period of five (5) years from date of manufacture. If any part is found to be defective during this period, new parts will be furnished free of charge. Failure of this product due to misuse, improper installation, alterations, vandalism, or lack of maintenance is not covered under this warranty, and voids any other implied warranties herein.

PowerMaster is not responsible for any labor charges incurred in connection with the installation of warranted parts.

In order to activate this warranty, the registration form below **MUST BE COMPLETED AND RETURNED WITHIN THIRTY CALENDAR DAYS FROM DATE OF PURCHASE**. Log onto our website at [www.vepower.net](http://www.vepower.net) and click on the *Register your Product* link. You can also send via fax (631-231-4274) or via email to [pmtech@optonline.net](mailto:pmtech@optonline.net). If registration is not activated, a one-year warranty will apply.

### REGISTRATION INFORMATION

#### Operator Information

Model **ASW**

Serial # \_\_\_\_\_

Date Installed \_\_\_\_\_

#### Location Installed

Address \_\_\_\_\_

Address \_\_\_\_\_

Address \_\_\_\_\_

#### Installer's Information

Company Name \_\_\_\_\_

Address \_\_\_\_\_

Address 2 \_\_\_\_\_

City, State, Zip \_\_\_\_\_

Telephone # \_\_\_\_\_

Contact Name \_\_\_\_\_

# PowerMaster

## Limited 5-Year Warranty

PowerMaster warrants all GATE OPERATORS (Swing, Slide, Barrier categories) to be free of defects in materials and workmanship for a period of five (5) years from date of manufacture, provided that product has been registered. A one year warranty applies if product has not been registered.

**ELECTRICAL PARTS** (including boards, switches, relays, etc):

PowerMaster warrants electrical parts for a two (2) year period, provided that product has been registered. A one year warranty applies if product has not been registered.

If any part is found to be defective during this period, new parts will be furnished free of charge. Failure of this product due to misuse, improper installation, alterations, vandalism, acts of God, or lack of maintenance is **not** covered under this warranty, and voids any other implied warranties herein.

PowerMaster is **not responsible** for any labor charges incurred in connection with the installation of warranted parts.

In order to activate this warranty, the registration form found with your operator **MUST BE COMPLETED AND RETURNED WITHIN THIRTY CALENDAR DAYS FROM DATE OF PURCHASE**. Visit our website at [www.PowerMasterNY.com](http://www.PowerMasterNY.com) and click on the **Register your Product** link.

If registration is not activated, a **ONE YEAR** warranty from date of manufacture will apply for all claims.

### REGISTRATION INFORMATION

#### **Operator Information**

Model ASW

Serial # \_\_\_\_\_

Date Installed \_\_\_\_\_

#### **Location Installed**

Address \_\_\_\_\_

Address \_\_\_\_\_

Address \_\_\_\_\_

#### **Installer's Information**

Company Name \_\_\_\_\_

Address \_\_\_\_\_

Address 2 \_\_\_\_\_

City, State, Zip \_\_\_\_\_

Telephone # \_\_\_\_\_

Contact Name \_\_\_\_\_

*The end user should retain this information for their records and to obtain warranty service.*

## Need Technical Support?

Visit: [www.PowerMasterNY.com/faqs](http://www.PowerMasterNY.com/faqs)

Call us toll free @ 1-800-243-4476

Email us: [PMtech@PowerMasterNY.com](mailto:PMtech@PowerMasterNY.com)



[www.facebook.com/PowerMasterOperators](http://www.facebook.com/PowerMasterOperators)



Scan **QR Code**  
with your Smart  
phone to **find us**  
on the web!

[www.PowerMasterNY.com](http://www.PowerMasterNY.com)

 **powermaster**  
MANUFACTURED BY V.E. POWER DOOR CO, INC.