



INSTALLATION AND OWNER'S MANUAL

MODEL RSG

Residential Slide Gate Operator

UL 325 and UL 991 Listed



Serial #:
Date Installed:
Your Dealer:

READ THIS MANUAL CAREFULLY
BEFORE INSTALLATION OR USE.
SAVE THESE INSTRUCTIONS.



Table of Contents

Model RSG Residential Slide Gate Operator

Important Safety Information	3
Important Notice for Gate Operators Manufactured after 1/11/16	4
UL Installation and Safety Considerations.....	5
System Designer Safety Instructions.....	6
Installer Safety Instructions	7-8
End User Safety Warnings	9-10
Manual Operation	11
Safety Warnings	12

Installation & Setup Procedure

Before Installing Operator.....	13
Installation of Cement Pad.....	14
Installation of Operator	15
Attaching Drive Chain	15-17
Electrical Connections	18
Limit Adjustment	19
Master/Slave Installation.....	21
Timer to Close.....	21

Accessory Connections

Connection of a 3-Button Station.....	22
Connection of a Radio	22
Loop Detector Systems	23
Loop Installation (Standard Layout Chart).....	24
Cutting the Required Groove	24
Loop Connections.....	23-25

Safety Device Connections

Inherent Obstruction Sensing Device	26
Secondary Obstruction Sensing Devices	26-29
Contact - Sensing Edge	27
Non-contact - Photo Eyes	28

Warranty	31
-----------------------	----

IMPORTANT!

FOR SLIDE GATE OPERATING SYSTEMS, SAFETY IS EVERYONE'S BUSINESS.

Automatic gate operators provide convenience and security to users. However, because these machines can produce high levels of force, it is important that all gate operator system designers, installers, and end users be aware of the potential hazards associated with improperly designed, installed, or maintained systems. Keep in mind that the gate operator is a component part of a total gate operating system.

The following information contains various safety precautions and warnings for the system designer, installer and end user. These instructions provide an overview of the importance of safe design, installation, and use.

Warnings are identified with the ▲ symbol. This symbol will identify some of the conditions that can result in serious injury or death. Take time to carefully read and follow these precautions and other important information provided to help ensure safe system design, installation and use.

▲ **WARNING:** Gate operators are only one part of a total gate operating system. It is the responsibility of purchaser, designer, and installer to ensure that the total system is safe for its intended use. All secondary entrapment safety devices must be **RECOGNIZED BY UL** to ensure the safety of the complete operating system.

▲ **WARNING:** This operator is only intended for installation on gates used for vehicular traffic. A separate pedestrian access opening shall be provided which is designed to promote pedestrian usage and shall be located such that persons will not come in contact with the vehicular gate during its entire path of travel.

IMPORTANT NOTICE FOR GATE OPERATORS MANUFACTURED AFTER JANUARY 11TH, 2016

All gate operators manufactured after January 11th, 2016 must have a monitored input for each direction. In order to satisfy this requirement, all PowerMaster gate operators with the universal board will have one monitored input for each direction. The close photo (11) terminal will function for the close direction and the open photo (10) will function for the open direction. These terminals will look for, or “monitor”, the presence of a 10k in-line resistor. If either terminal does not detect the presence of the monitored device, the unit will function in constant contact for this direction.

Note: The first time a monitored device is added to the unit, the board must “learn” what the monitored device is. To have the board learn the monitored device, perform the following steps:

1. With the power off, hold both the open and close limit simultaneously.
2. Power up the unit and release your fingers from the limits. The unit has now learned the monitored device.

E.g. The operator detects there is a monitored device on the 11 terminal but not the 10 terminal. The operator will function in momentary contact to close and constant pressure to open.

Following are the monitored devices acceptable for use with the GSMCB02:

Device	Manufacturer	Description
Prime-Guard	Miller Edge	Monitored Photoeye
Reflecti-Guard	Miller Edge	Retroreflective Monitored Photoeye
IRB-MON	EMX	Monitored Photoeye
IRB-RET	EMX	Retroreflective Monitored Photoeye
The Solution	Miller Edge	Multiple Safety Devices

Any actions taken to circumvent this monitoring are in violation of the UL325, building code, and local laws.

UL INSTALLATION AND SAFETY CONSIDERATIONS

INSTALLATION CLASSES

CLASS I - RESIDENTIAL VEHICULAR GATE OPERATOR

A vehicular gate operator (or system) intended for use in a home of one to four single-family dwellings, or a garage or parking area associated therewith.

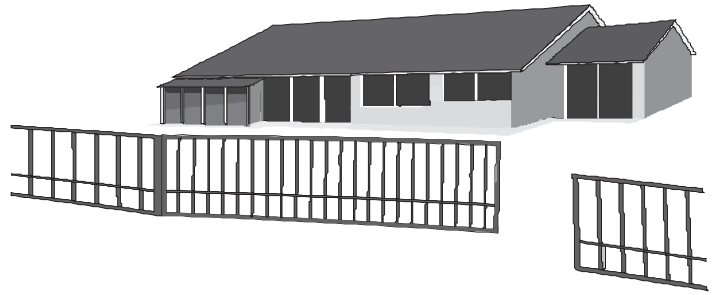

CLASS II – COMMERCIAL/GENERAL ACCESS VEHICULAR GATE OPERATOR

A vehicular gate operator (or system) intended for use in a commercial location or building such as a multifamily housing unit (five or more single family units), hotel, garages, retail store or other building servicing the general public.

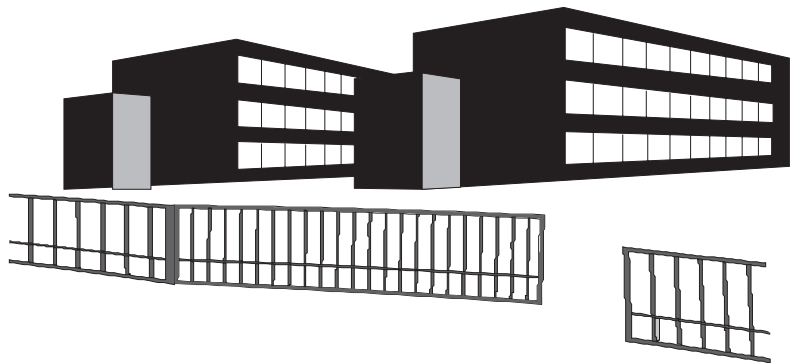

CLASS III - INDUSTRIAL/LIMITED ACCESS VEHICULAR GATE OPERATOR

A vehicular gate operator (or system) intended for use in an industrial location or building such as a factory or loading dock area or other locations not intended to service the general public.

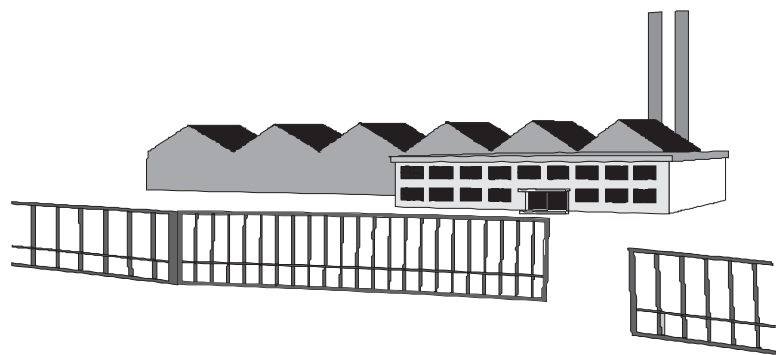

CLASS IV - RESTRICTED ACCESS VEHICULAR GATE OPERATOR

A vehicular gate operator (or system) intended for use in a guarded industrial location or building such as an airport area or other restricted access locations not servicing the general public, in which unauthorized access is prevented via supervision by security personnel.

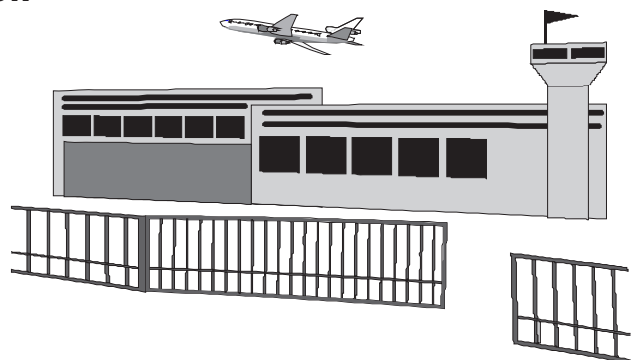

SYSTEM DESIGNER SAFETY INSTRUCTIONS

- ▲ 1. Familiarize yourself with the precautions and warnings for the installer. Users are relying on your design to provide a safe installation.
- ▲ 2. The operator is supplied with a primary obstruction sensing entrapment protection system. The installation must also have a secondary entrapment protection system installed, such as photoelectric sensors or an electric edge system.
- ▲ 3. When designing a system that will be entered from a highway or main thoroughfare, be sure the system is placed far enough away from the road to eliminate traffic backup. Distance from the road, size of the gate, usage levels, and gate cycle/speed must be considered to eliminate potential traffic hazards.
- ▲ 4. The majority of injuries from slide gate operator systems occur with Open Roller or Ornamental Grille Type Gates. We strongly recommend the use of roller guards. The illustrations and descriptive captions found on the following pages provide precautions to help eliminate injuries or fatalities. Familiarize yourself with them when designing the total system.
- ▲ 5. Design the gate system so a person cannot reach over, under, around, or through the gate to operate any controls. Never place controls on the gate operator itself.



INSTALLER SAFETY INSTRUCTIONS

BEFORE INSTALLATION

- ▲ 1. Check to see that the operator is proper for this type, size and class of gate and its frequency of use. If you are not sure, consult factory.
 - ▲ 2. Check to see that there are no structures adjacent to the area, which may pose a risk of entrapment when gate is opening or closing.
 - ▲ 3. You must ensure that the gate has been properly installed and works freely in both directions. Replace or service any worn or damaged gate hardware prior to installation. A freely moving gate will require less force to operate and enhance the performance of the operator as well as the safety devices used within the system.
 - ▲ 4. Install the gate operator on the inside of the property and/or fence line. **DO NOT** install an operator on the public side of the gate.
 - ▲ 5. Severe injury or death can result from entrapment by a gate. The operator is supplied with an obstruction sensing primary entrapment protection system. Additional safety equipment such as electric edges or photocell sensors must be installed to provide the required secondary entrapment protection system. For assistance in selecting the correct type of safety equipment, consult the factory.
 - ▲ 6. Review the operation of the unit and become familiar with the manual operation procedure and safety features of the system.
 - ▲ 7. You must install a pushbutton control or key switch to allow for normal operation of the gate if the automatic controls do not work. Locate the push button or key switch and small warning placard within sight of the gate in a secured area at least 10 feet or more from the gate and fence to keep users away from the moving gate and fence.
 - ▲ 8. Outdoor or easily accessed gate controls should be of the security type to prohibit unauthorized use. Please consult your local distributor concerning the types and specifications of available controls.
-

DURING INSTALLATION

- ▲ 1. Be aware of all moving parts and avoid close proximity to any pinch points.
- ▲ 2. Disconnect power at the control panel before making any electric service connections. Connection location for controls and safety equipment can be found on the wiring diagram, and in this manual.
- ▲ 3. Know the procedure for engaging and manually operating the unit.
- ▲ 4. Adjust the open and close force adjustment on the control board, in each direction, to the minimum force required to operate the gate smoothly. **DO NOT increase the force adjustment setting to make up for rough spots in gate travel - FIX THE GATE INSTEAD!**

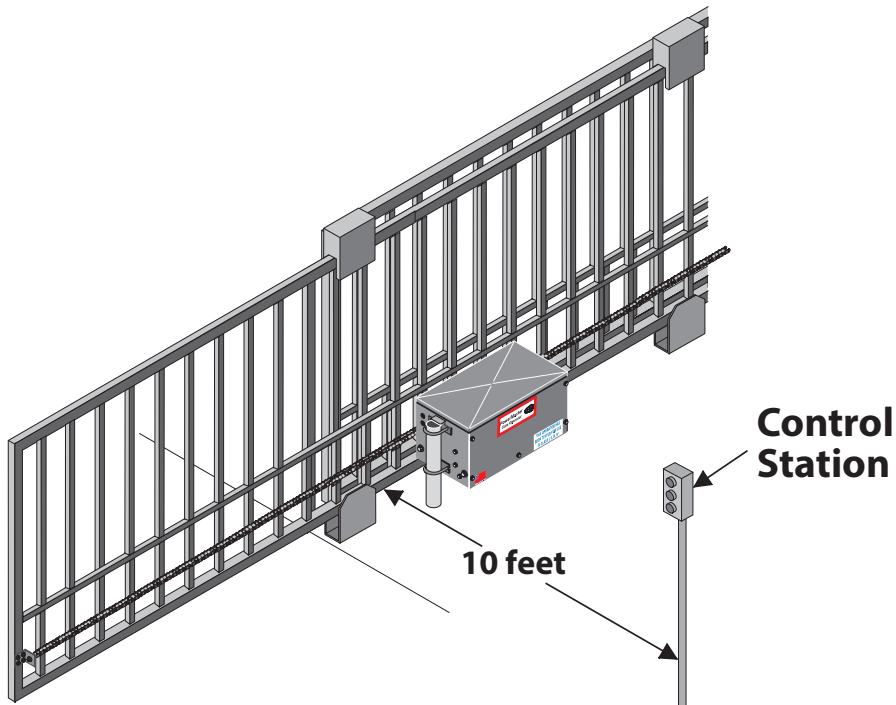

- ▲ 5. Locate the controls at least 10 feet from the moving gate so that the user can observe the gate operation, but is not able to come in contact with the gate while operating the controls.

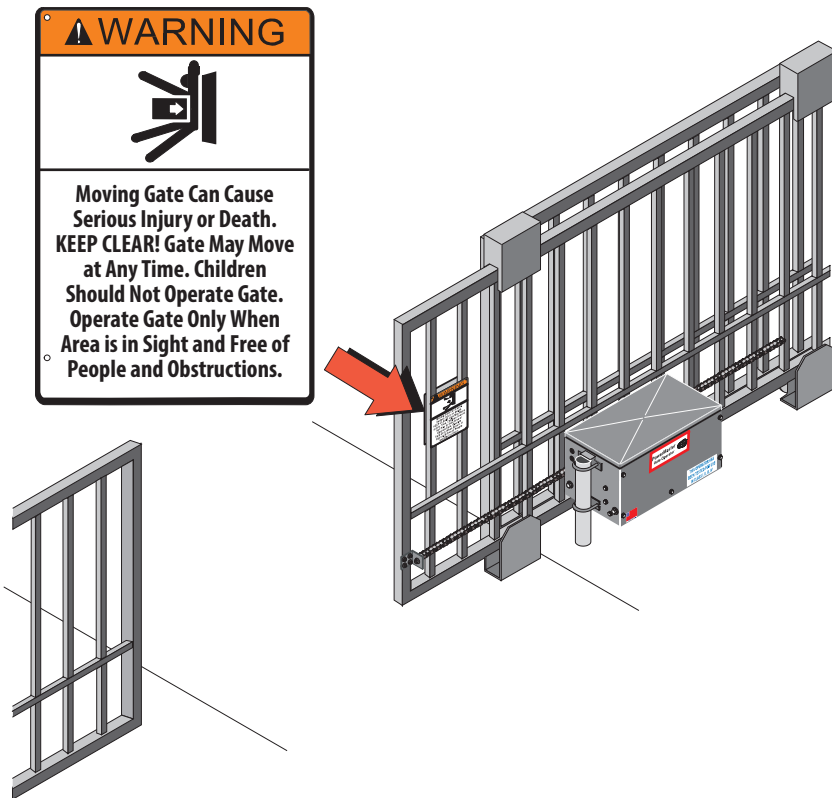

- ▲ 6. Attach large warning signs provided to each side of the gate or fence in the most conspicuous place. Mount control station and smaller warning placard together within sight of the gate opening.

AFTER INSTALLATION

- ▲ You are responsible for ensuring that the end user understands the basic operations and safety systems of the unit, **INCLUDING THE MANUAL OPERATION PROCEDURE.**
- ▲ Point out that the safety instructions in brochure are the responsibility of the end user, and then **LEAVE THIS MANUAL WITH THE END USER.**

END USER SAFETY WARNINGS

The manufacturer of the gate operator does not know what type of gate you have, or what type of automatic system is installed on your gate. Be sure you've been fully instructed on the sequence of operation for your specific gate system(s). Keep the gate properly maintained and have a qualified service person make repairs.

- ▲ 1. Be sure the following safety instructions are distributed to all persons authorized to use your gate.
- ▲ 2. **KEEP GATEWAY CLEAR (Front and Back) AT ALL TIMES.** Your automatic gate is not for pedestrian use. No one should ever cross the path of the moving gate.
- ▲ 3. DO NOT allow children to play near your gate, or to operate the gate.
- ▲ 4. DO NOT operate your gate system unless you can see it when the gate moves.
- ▲ 5. Be sure a pushbutton or key switch has been installed for manual electric operation in the event your radio or card key does not work. Any mounted control station should be located a minimum of 10 feet from the gate so the gate cannot be reached through or touched. Any pushbutton located in a building should be installed within sight of the gate.
- ▲ 6. DO NOT operate any controls without watching the movement of the gate.

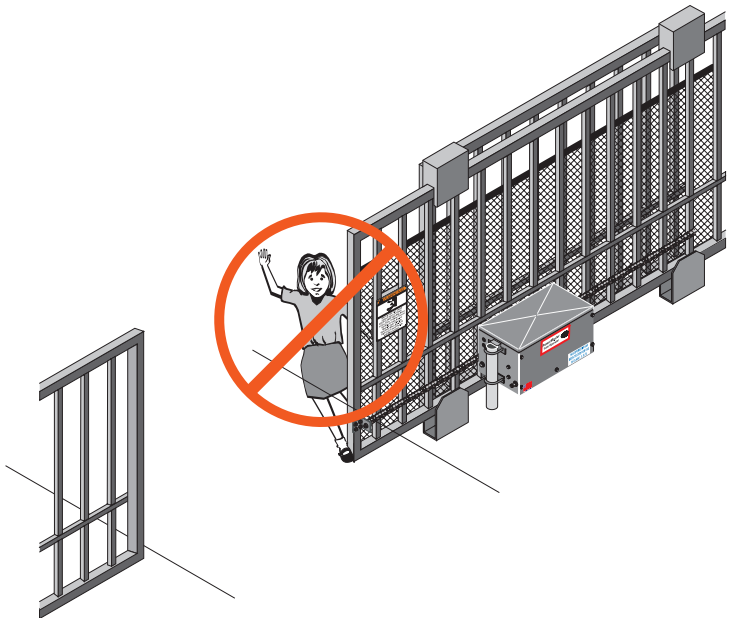

- ▲ 7. If your gate has open rollers, be sure roller guards have been purchased and installed.

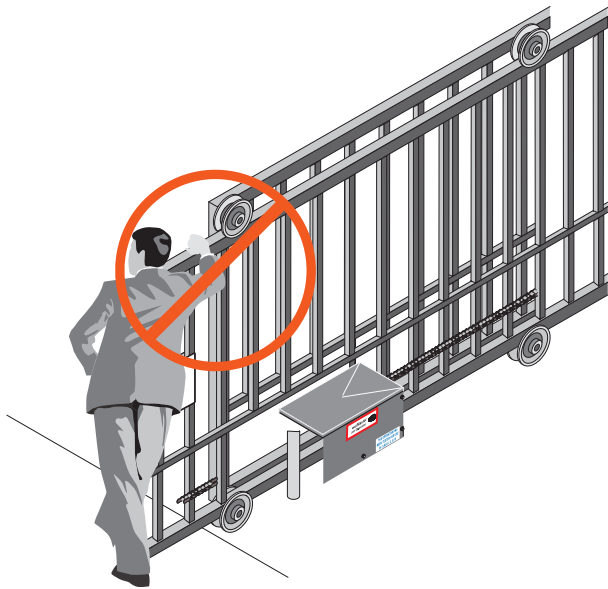

INCORRECT

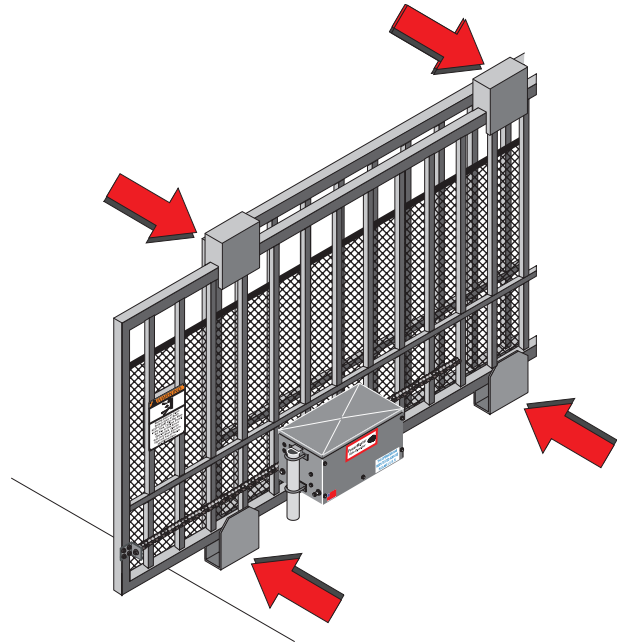

CORRECT

- ▲ 8. Your gate system is required to have a primary and a secondary entrapment safety system installed and maintained.
- ▲ 9. If your gate closes automatically, loop detectors should be installed to detect the presence of a vehicle.
- ▲ 10. DO NOT increase force adjustment to compensate for a damaged gate. The gate should always be maintained to operate manually as easily as possible to provide maximum protection.
- ▲ 11. Check all safety systems at least once per month for the correct force, speed and sensitivity. Gate must reverse when hitting a rigid object, or when a non-contact sensor is activated. **If these functions are observed to operate improperly, discontinue use and have it serviced immediately!**
- ▲ 12. You are responsible for ensuring that warning signs are installed and maintained on both sides of your gate.
- ▲ 13. To ensure safe operation of this equipment, you must read this safety manual and keep it for reference.

MANUAL OPERATION

Your operator is equipped with an emergency disconnect for manual operation. Be sure you know how to properly use this feature. To disengage operator, follow the procedure in **Figure 1**.

FIGURE 1

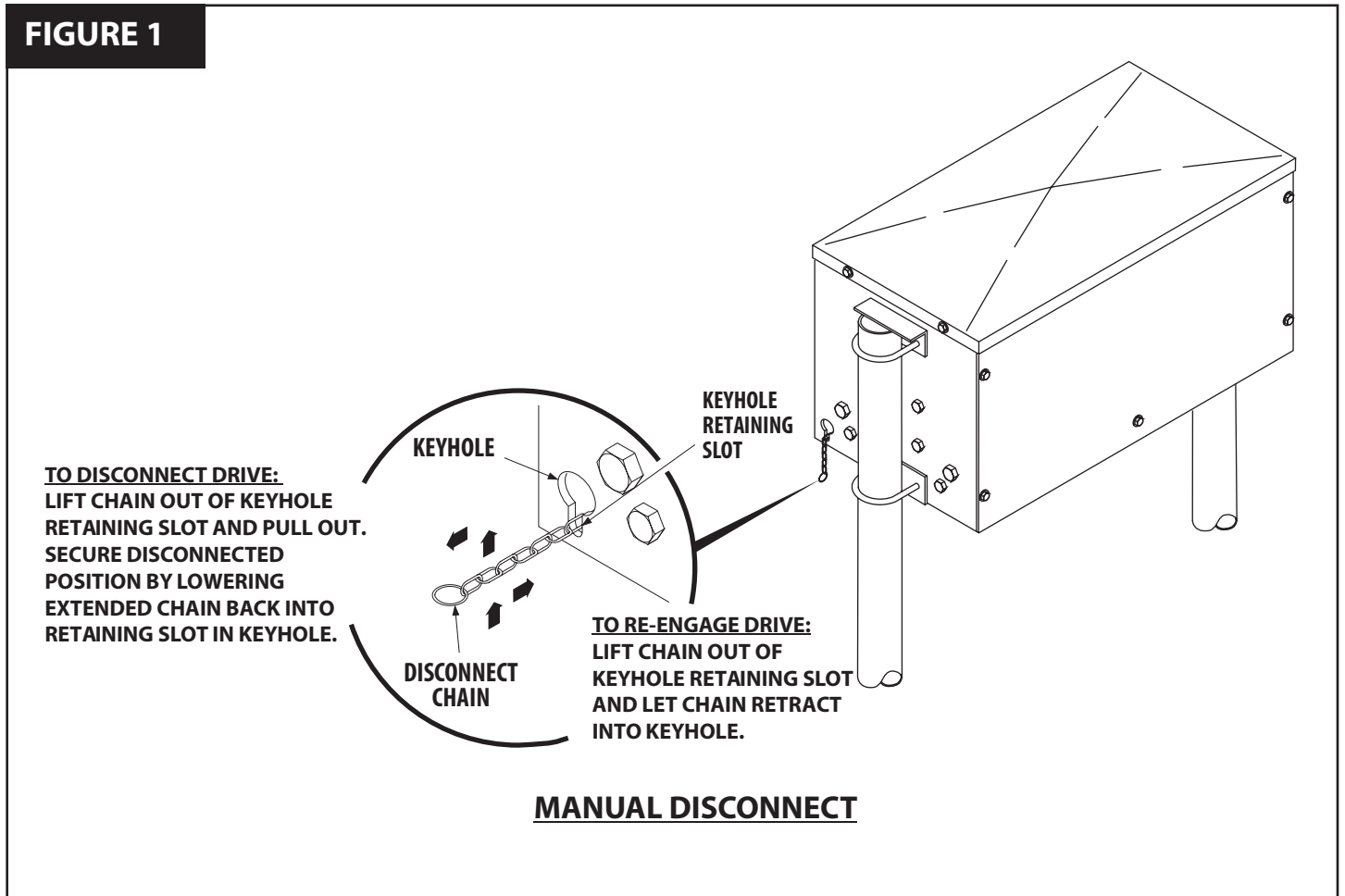

WARNING

**NEVER ATTEMPT TO OPERATE THE MANUAL
RELEASE WHEN THE GATE IS IN MOTION!**

SAFETY WARNINGS FOR OPEN-ROLLER GATES AND ORNAMENTAL GRILLE-TYPE GATES



WARNING

INJURIES ASSOCIATED WITH AUTOMATIC GATES ARE MAINLY INCURRED WITH OPEN-ROLLER GATES AND ORNAMENTAL GRILLE TYPE GATES.

OPEN-ROLLER GATES

- ▲ Injuries occur when people get their hands caught between the top of the gate and the roller. This potential pinch point should be guarded whenever an automatic operator is installed. Roller Guards are available from various fence suppliers for refitting of these rollers.

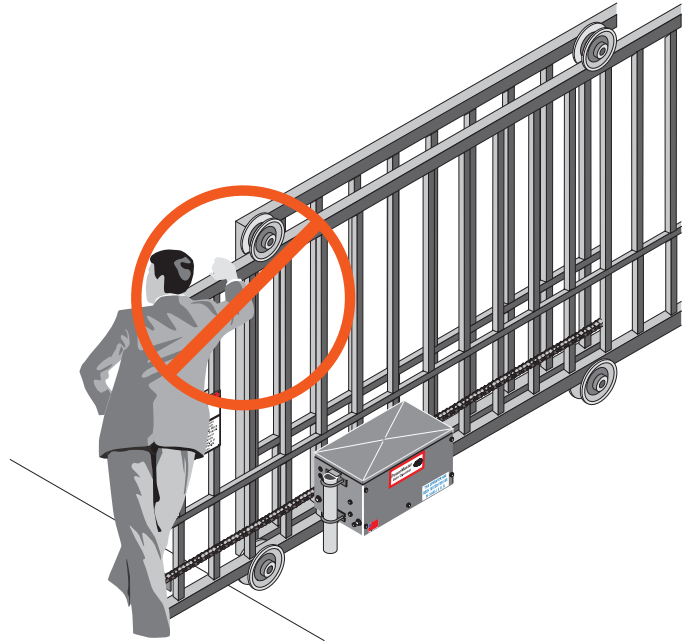

ORNAMENTAL GRILLE-TYPE GATES

- ▲ Injuries occur when people put their arms through openings in the grilles when the gate is operated. The person cannot retract his/her arm and it gets caught between the grille and the fence post or fence. The potential hazard must be guarded. It can be simply done by placing a screen mesh on the gate and fence in the area of the gate. The screen must be a minimum of 4 feet high from the bottom (unless the gate and fence are shorter) with openings that a 2¼-inch sphere cannot fit through. This will help to prevent access through openings when the gate travels.

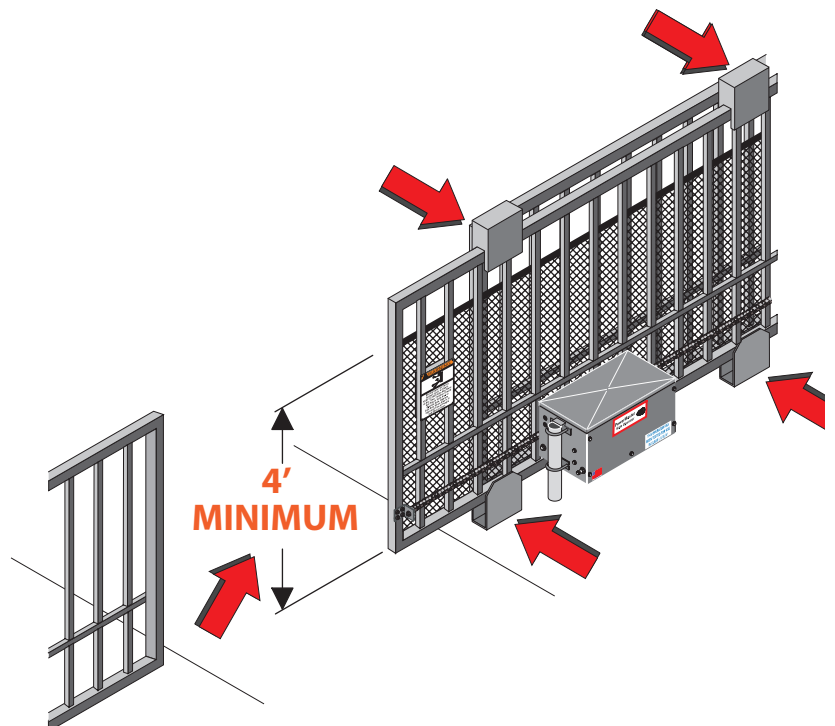

INSTALLATION INSTRUCTIONS & SET-UP PROCEDURE



WARNING

DO NOT APPLY POWER UNTIL TOLD TO DO SO! RISK OF ELECTRICAL SHOCK OR INJURY MAY RESULT!

BEFORE INSTALLING OPERATOR

IMPORTANT: Operator should always be mounted inside the gate. Determine whether the installation is Left hand or Right hand by the direction the gate moves in order to open, when viewed from inside the fence.

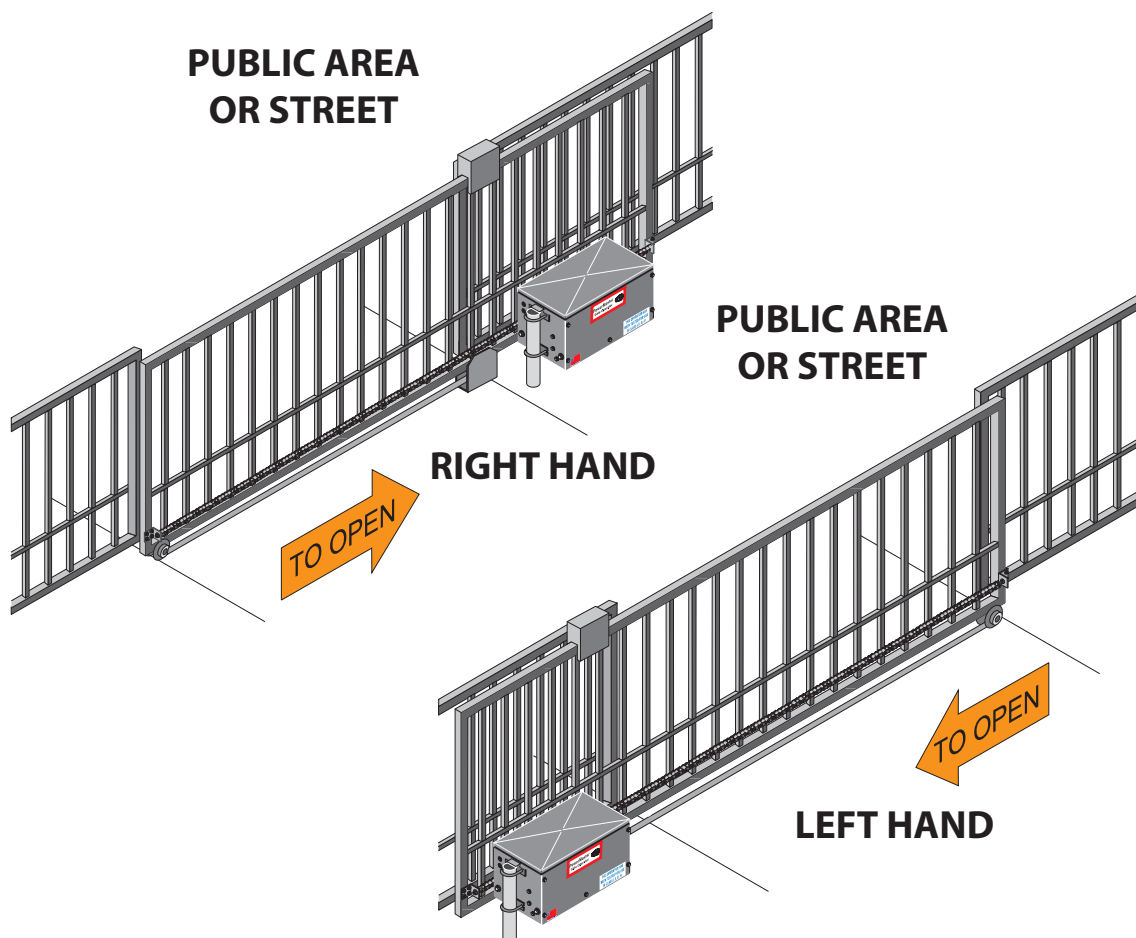

1. Gate must slide freely to fully opened and fully closed position.
2. Gate and/or extension must extend beyond the position of the operator when gate is in a fully closed position. The operator will be located as shown above, for left and right hand installation.

INSTALLATION LAYOUT

1. Layout mounting post and electrical conduit locations as shown in **Figures 2 & 3** below.
2. Excavate required area for conduit installation and cementing of mounting posts (Minimum of 2 feet deep, check local codes).
3. Set mounting post and electrical conduit in place.
4. Pour cement to secure mounting posts and let cure for two days prior to operator installation.

Note: Distance between mounting posts and relative location to gate is very important! Operator must be installed parallel to the gate. Drive sprocket and idlers must face the fence.

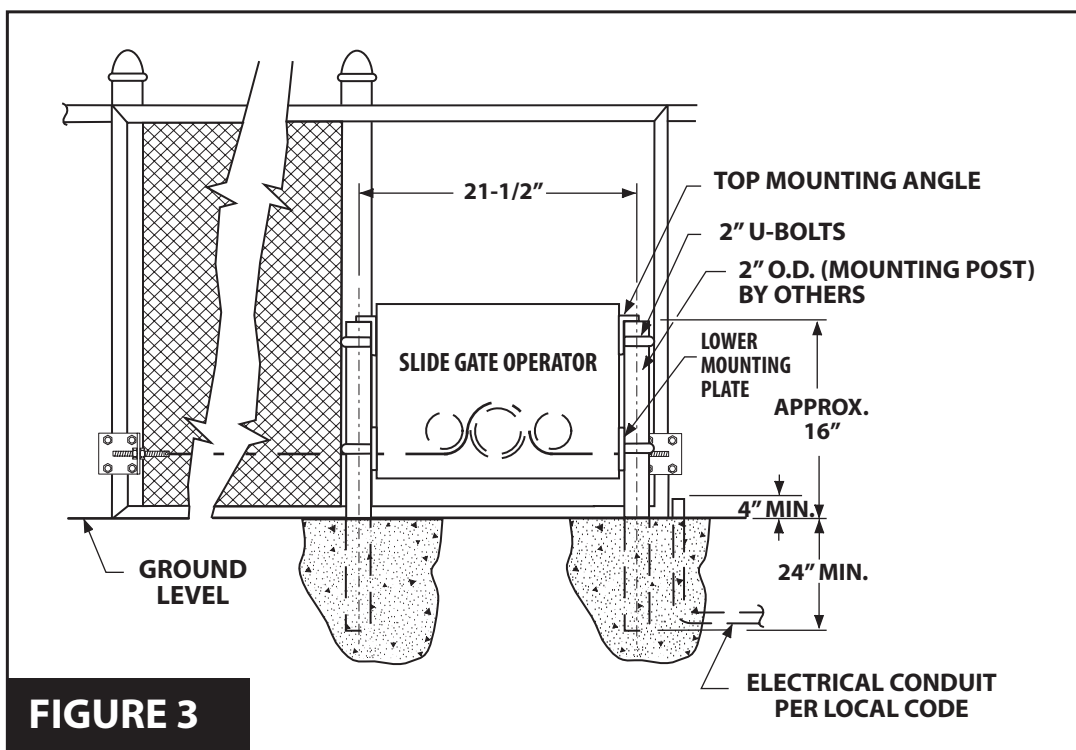
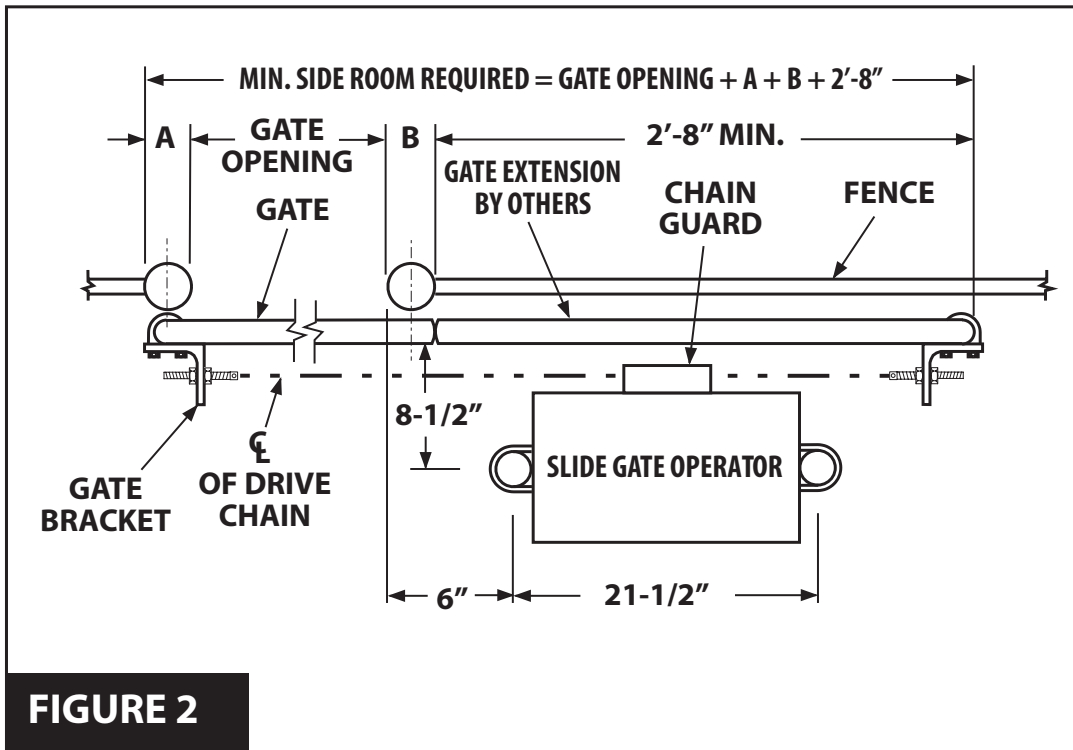

OPERATOR INSTALLATION

1. Remove operator top cover and chain guard for access. If gate extension is required, do so before installing operator. See **Figure 2**.
2. Operators are shipped from the factory as *Slide right to open*. For *Slide left to open*, remove idler brace, turn idler brace upside down, and reinstall using upper hole pattern. See **Figure 4**.

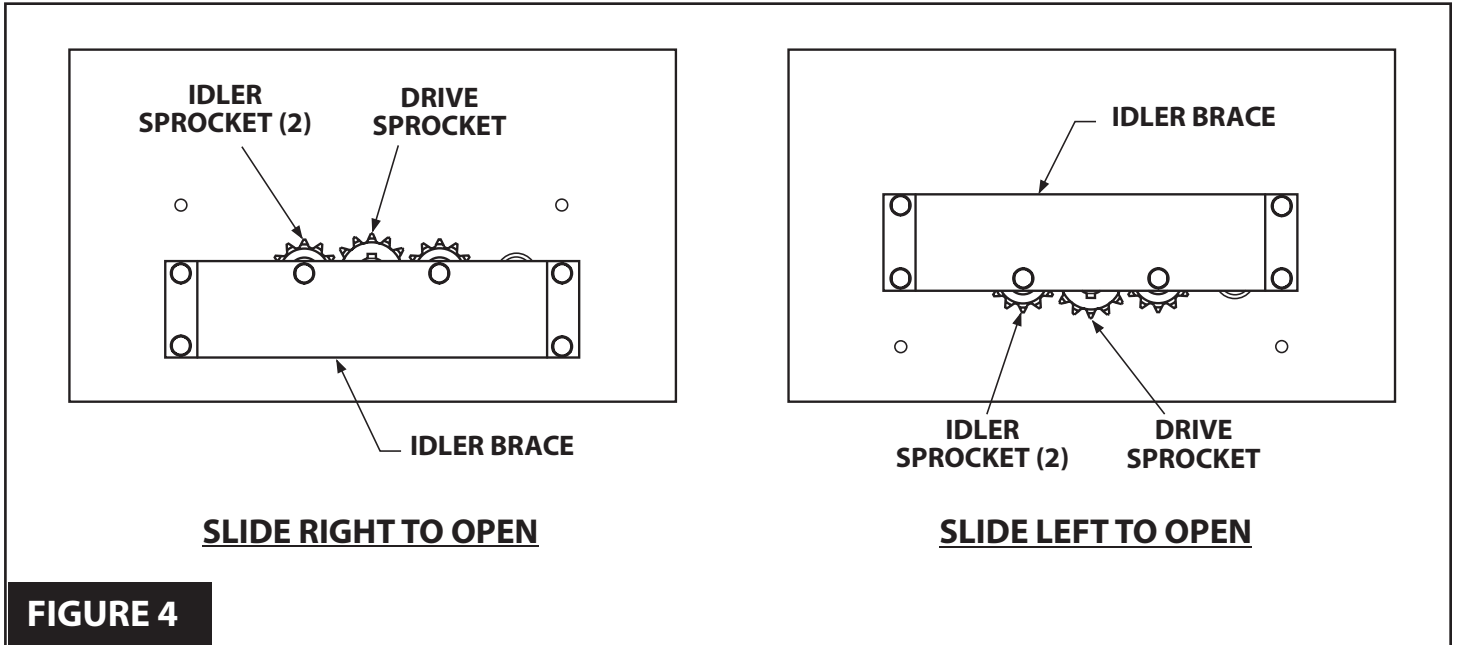

3. Mount operator on posts with U-bolts, mounting angles, mounting plates and hardware provided. See **Figure 3**.

ATTACHING DRIVE CHAIN

1. Install gate brackets at each end of the gate with the U-bolts provided. Height of gate bracket center line is to be even with the drive chain exiting operator. See **Figure 5**. Do not fully tighten at this time.
2. Attach a chain take-up bolt to one end of the drive chain using a #41 connecting link and install in slot of the furthest gate bracket from the operator. Secure it in position with 3/8 inch nuts, washers, and lock washer. See **Figure 5**.

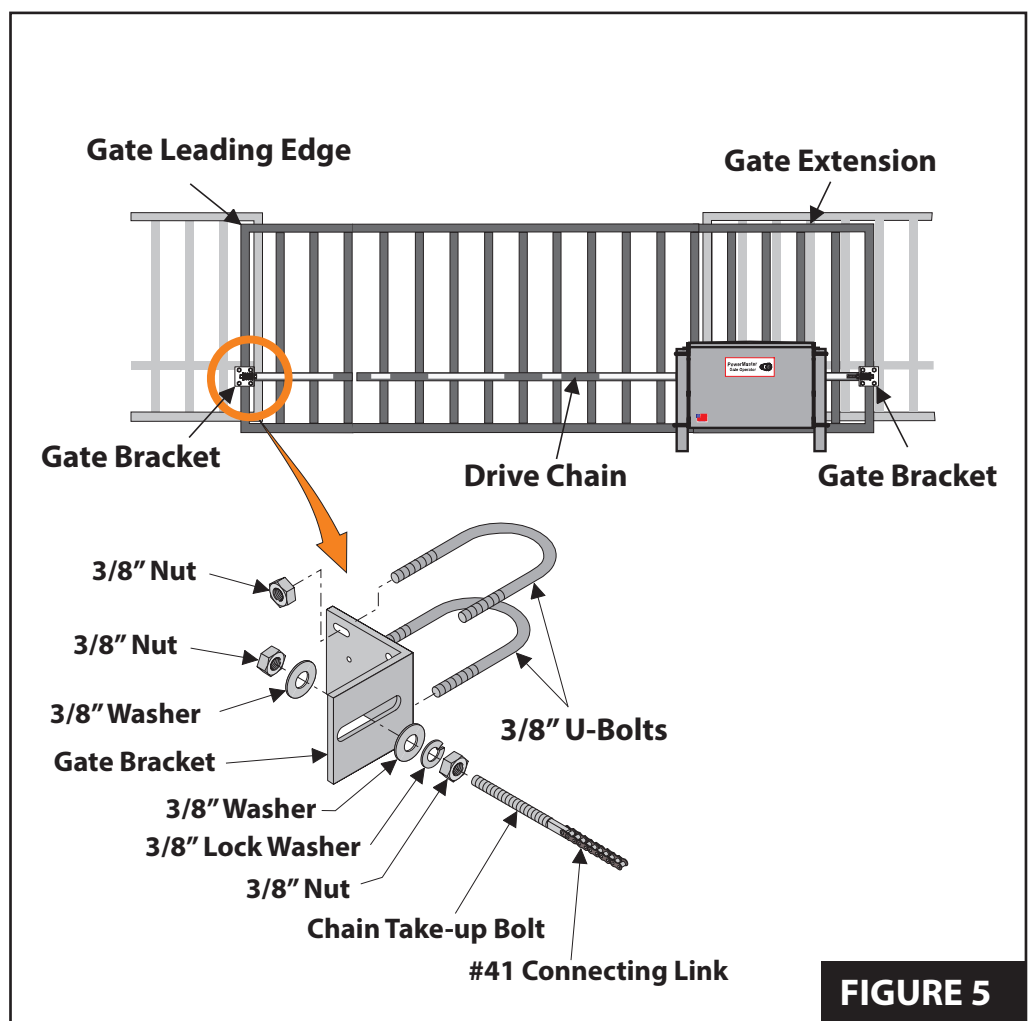

- Disengage power drive unit by pulling on disconnect chain and secure in disconnected position by lowering extended chain into retaining slot in keyhole.

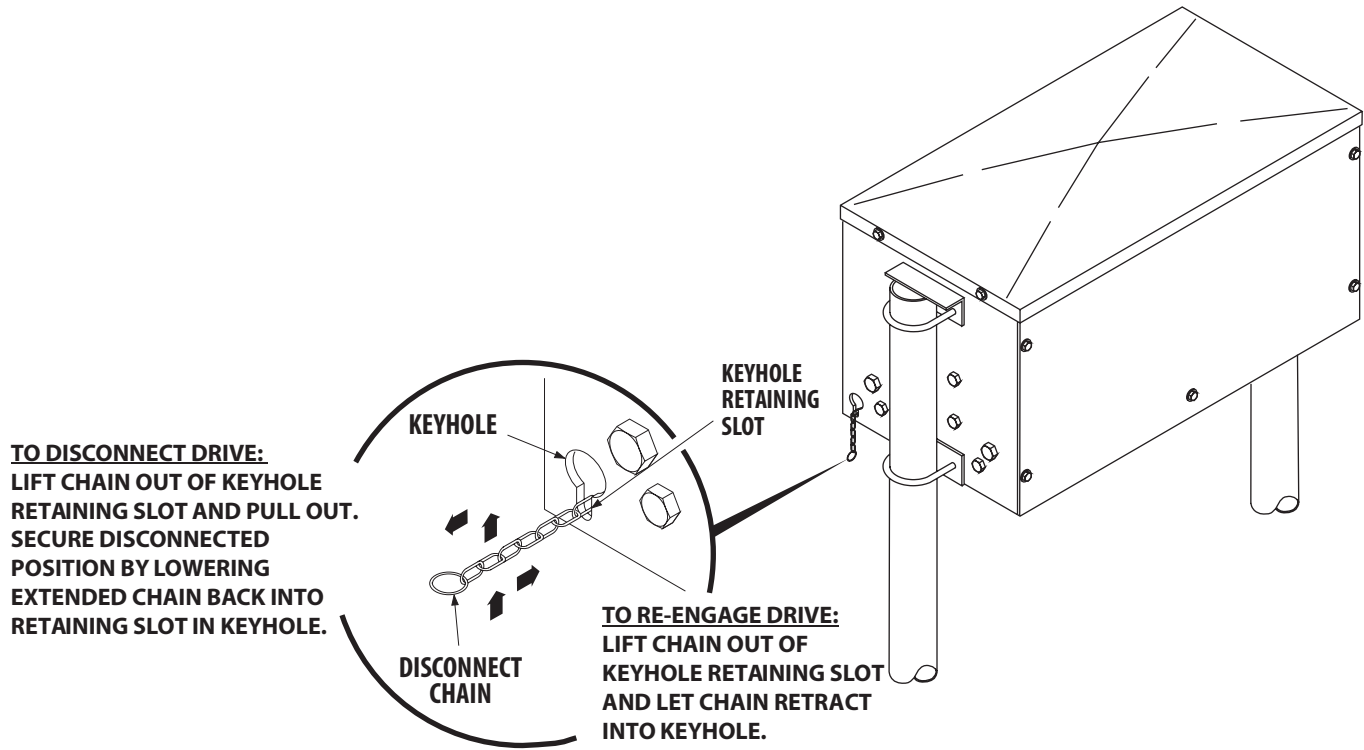

MANUAL DISCONNECT

- Thread chain past first idler sprocket, around drive sprocket, then past the second idler sprocket. See **Figure 6**.

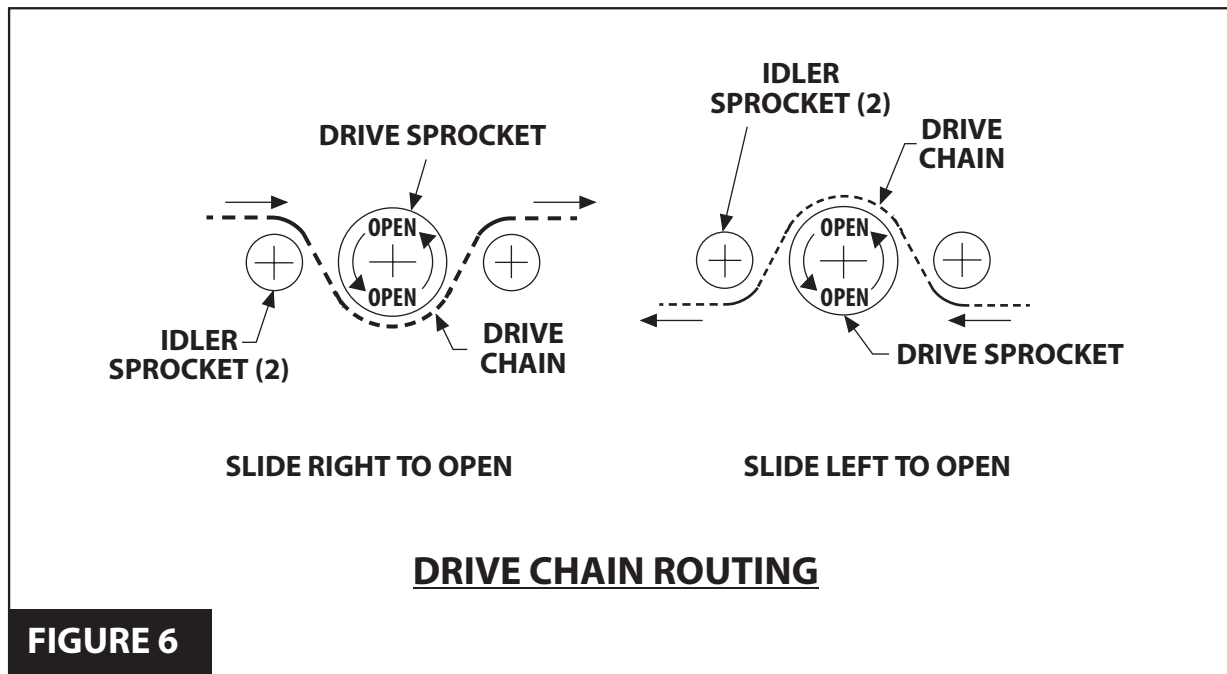

FIGURE 6

Note: When pulling chain through operator sprockets, the limit nuts in the electric box can be driven passed their normal position. Reset limit nuts as necessary to prevent them from being damaged during this procedure.

5. Pull drive chain through the operator until all excess chain between operator and gate bracket has been removed.
6. Re-engage operator drive by lifting disconnect chain out of keyhole retaining slot and allow chain to retract into keyhole.
7. Move gate to tighten drive chain between operator drive sprocket and gate bracket, and secure gate position with rope or chock.
8. Measure out required length of drive chain needed for attaching to remaining gate bracket. Cut the chain to the correct length, attach remaining chain take-up bolt and install in the gate bracket as in **Step #2**.
9. Adjust the gate bracket height at both ends of the gate to ensure the drive chain aligns with the operator idler sprockets. Tighten the gate brackets securely and lock in position with the setscrews provided.
10. Align drive chain to the drive sprocket and ensure it is parallel to gate using slots in gate bracket as shown.

NOTE: If required, reposition drive sprocket by loosening set screws and relocating drive sprocket on operator drive shaft. Tighten set screws after desired location is obtained.

NOTE: By moving the gate manually to each end of its travel, chain alignment is simplified.

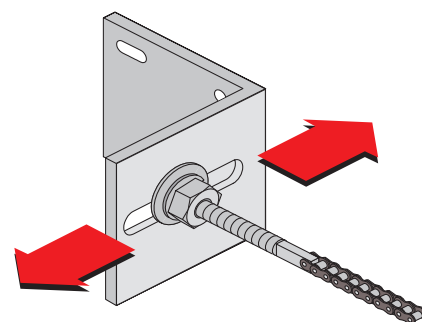

11. Adjust chain tension using chain take up bolts and outside nuts. See **Figure 5**.

NOTE: Adjust drive chain tension so that the chain is well supported but not binding on operator drive sprockets. Check for binding by disengaging the operator with the manual disconnect and pushing gate by hand. A chain that is too loose will cause excessive jerking of the gate when the operator starts.

12. When the desired chain tension is achieved, lock position with inside nuts on chain take up bolts. See **Figure 5**.
13. Replace chain guard.

ELECTRICAL SET-UP AND CONNECTIONS



WARNING

DO NOT APPLY POWER UNTIL TOLD TO DO SO! RISK OF ELECTRICAL SHOCK OR INJURY MAY RESULT!

NOTE: Before connecting the operator, use a voltmeter to determine that the electrical service is 115V. **THIS OPERATOR CANNOT BE CONNECTED AT 230 VOLTS.** Damage will result which is not covered under warranty.

NOTE: Wiring to operator must use watertight materials in accordance with local electric code. See the following wire gauge/distance charts for proper sizing. Master/Slave installations should have SEPARATE power supply wiring or length of wire runs should be figured at half that shown on the chart. This unit must be grounded in accordance with N.E.C. and local codes.

LINE VOLTAGE	HP	WIRE GAUGE				
		16 AWG	14 AWG	12 AWG	10 AWG	8 AWG
115VAC	1/2	150'	250'	400'	500'	650'

LOW VOLTAGE WIRE GAUGE/ DISTANCE CHART
24 AWG: UP TO 150'
20 AWG: 150' - 200'
18 AWG: 250' - 1,500'
Control wiring should be run as twisted pairs. DO NOT run control wires in the same conduit as power wires, telephone wires, or loop detector leads.

1. Be sure the power switches at source, and at the operator are **OFF**.
2. Connect incoming power lines and ground wire as shown below.

Hot leg (Black) to Black; Neutral (white) to White; Ground to Ground Screw.

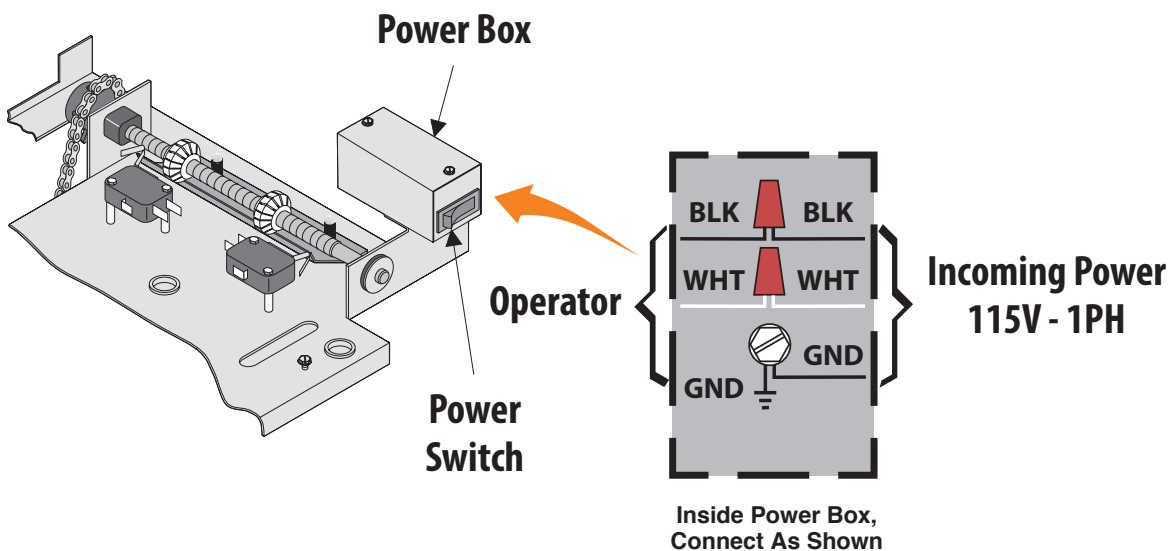

NOTE: In order to properly run and check the operator at various stages during the setup procedure, it is suggested that a three button control station be connected at this time.

LIMIT ADJUSTMENT PROCEDURE



WARNING

TURN OFF INCOMING POWER AT OPERATOR POWER BOX BEFORE STARTING THIS PROCEDURE.



WARNING

STAY CLEAR OF ALL MOVING PARTS AND ELECTRICAL COMPONENTS OF THE OPERATOR WHILE TESTING!

1. After the gate operator is mechanically installed, move the gate to a midway position using the manual disconnect.

NOTE: When moving the gate manually, the limit nuts in the electric box can be driven past their normal position. Reset the limit nuts as necessary, by depressing the pressure plate and rotating the limit nuts until they are both positioned near the center of the limit shaft.

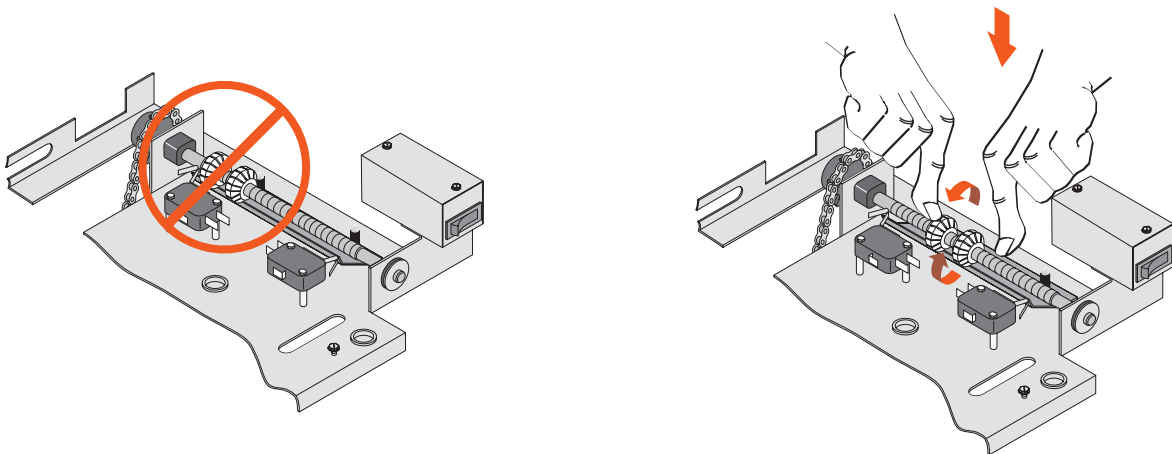

2. With the gate at mid travel, depress the pressure plate and set the grooved limit nuts approximately 1 inch from the limit switches on each side.

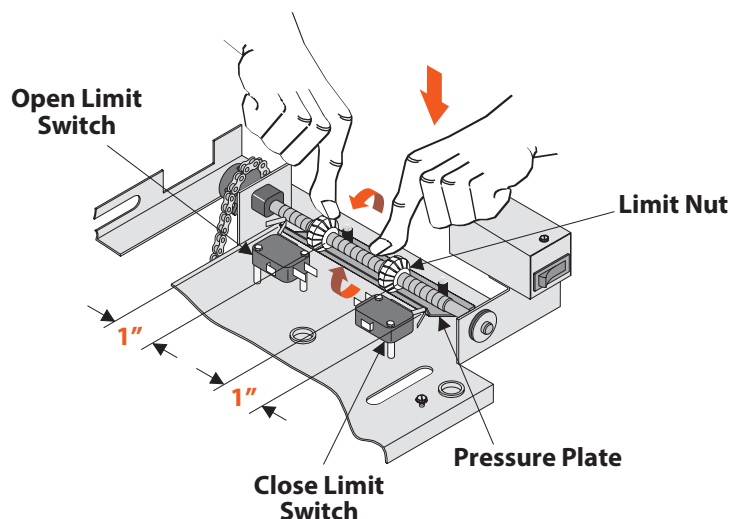

3. Turn **ON** power. Open the gate electrically. If the gate travels in the wrong direction, turn **OFF** incoming power and recheck drive chain installation (See **Figure 6**). If drive chain is correct, consult the factory.

4. If the gate travels in the correct direction, run the operator to the **Open Limit Switch** and turn **OFF** the power.
5. If the limit nut depresses the **Open Limit Switch** but does not stop the gate, press the **STOP** button or turn **OFF** the power immediately and consult factory (1-800-243-4476).

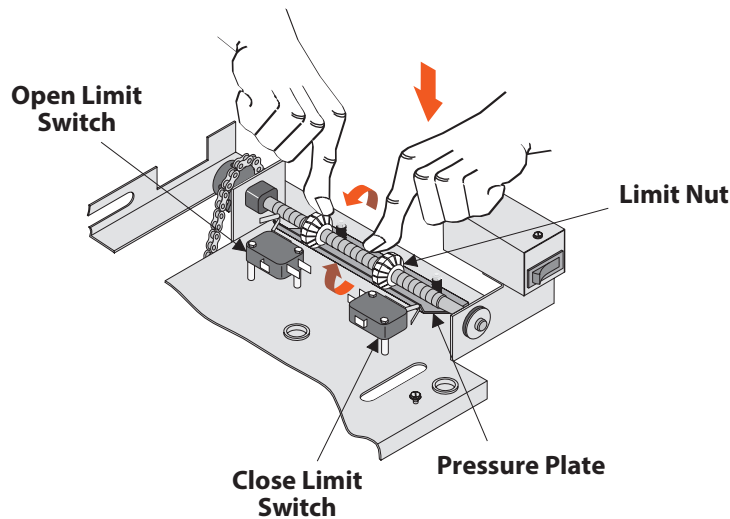

6. If there is still a distance before the gate is fully open, turn **OFF** power, move the **Open Limit Nut** away from the **Open Limit Switch** a few turns and turn **ON** the power.
7. Press the **OPEN** button again to check how much further the gate opened. Continue this procedure until the **OPEN** limit is set.

NOTE: When making fine adjustments, turn the limit nut one quarter turn at a time; reconnect power and test run the gate.

8. Repeat procedure for the **CLOSE LIMIT ADJUSTMENT**. After the desired open and close position of the gate has been obtained, make certain that a groove in both limit nuts are engaged by the pressure plate.

MASTER-SLAVE INSTALLATION

NOTE: A single unit is considered a Master. In a Master/Slave installation, one unit must be converted to **LEFT HAND** operation.

1. Place jumper on the **Master** operator's control board in the **OFF** position.
2. Place jumper on the **Slave** operator's control board in the **ON** position.
3. Connect Terminal #15 of **Master** unit to Terminal #5 of **Slave** unit.
4. Connect Terminal #16 from the **Master** unit to Terminal #6 on **Slave** the unit.
5. Connect Terminal #17 from the **Master** unit to Terminal #7 on the **Slave** unit.

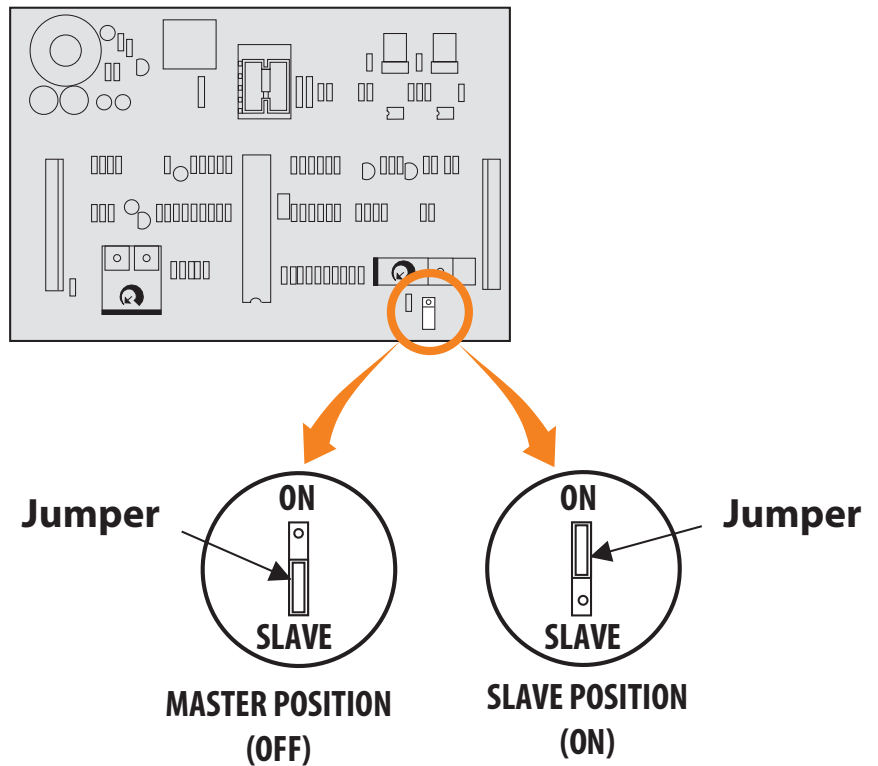

TIMER TO CLOSE OPTION

The operator is equipped with a **Timer to Close** option for use with other **OPEN CONTROL DEVICES** such as a radio control or card key control. The **AUTO CLOSE TIMER** adjustment screw is located on the printed circuit board. The operator is shipped from the factory with this timer preset to the off position; fully counter clockwise. As the timer adjustment screw is rotated clockwise, the closing of the gate can be delayed from 2 seconds to 60 seconds. The timer to close will be activated whenever the gate is fully opened.

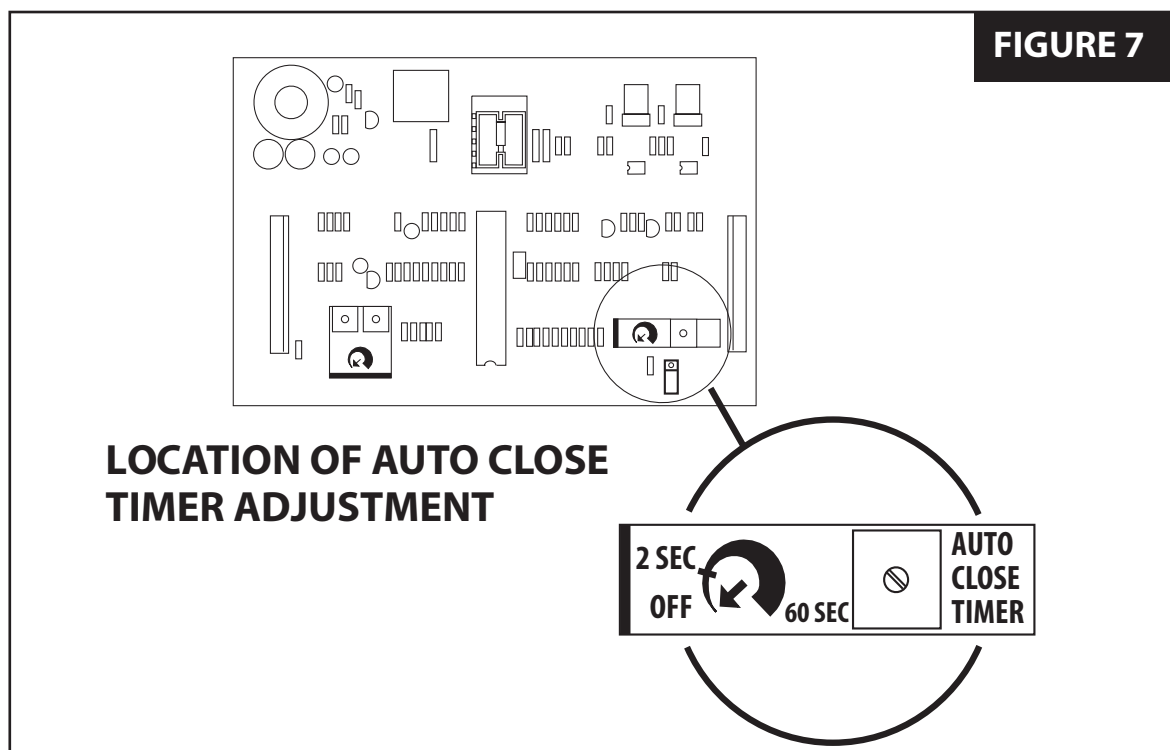

CONTROL CONNECTIONS

CONNECTION OF A 3-BUTTON STATION

NOTE: The 3 button station must have all normally open contacts for proper operation.

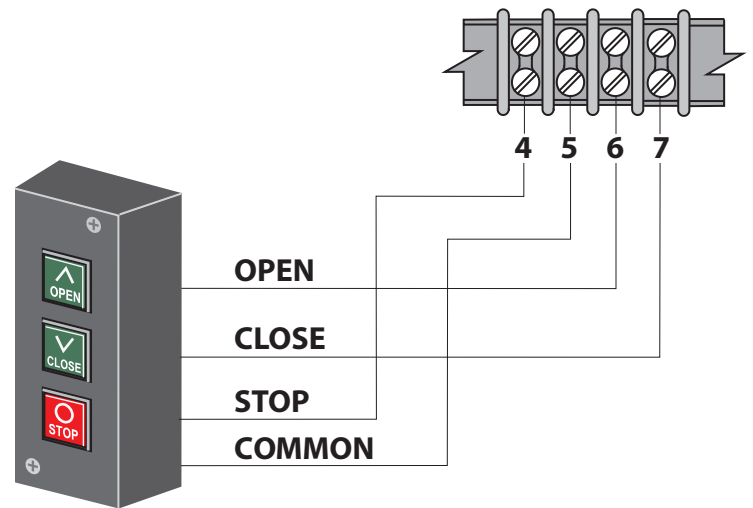

1. Connect a wire from the **COMMON** connection of the control station to Terminal #5.
2. Connect a second wire from the **OPEN** button of the control station to Terminal #6.
3. Connect a third wire from the **CLOSE** button of the control station to Terminal #7.
4. Connect a fourth wire from the **STOP** button of the control station to Terminal #4.

RADIO CONTROL INSTALLATION

A three or four-wire radio control receiver can be installed on this operator. See the **Figure 8** for the proper terminal connections.

NOTE: If your radio's connecting wires are not color coded as shown, see the radio's installation manual to determine which wires are for the normally open contacts and which require the 24 VAC Power Supply.

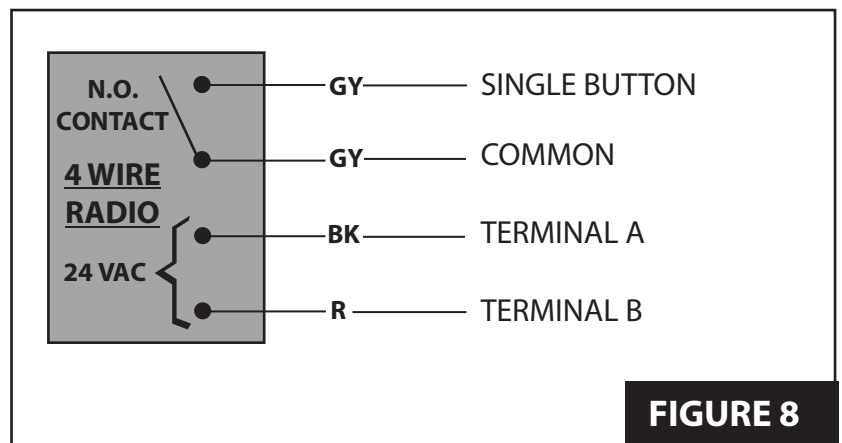
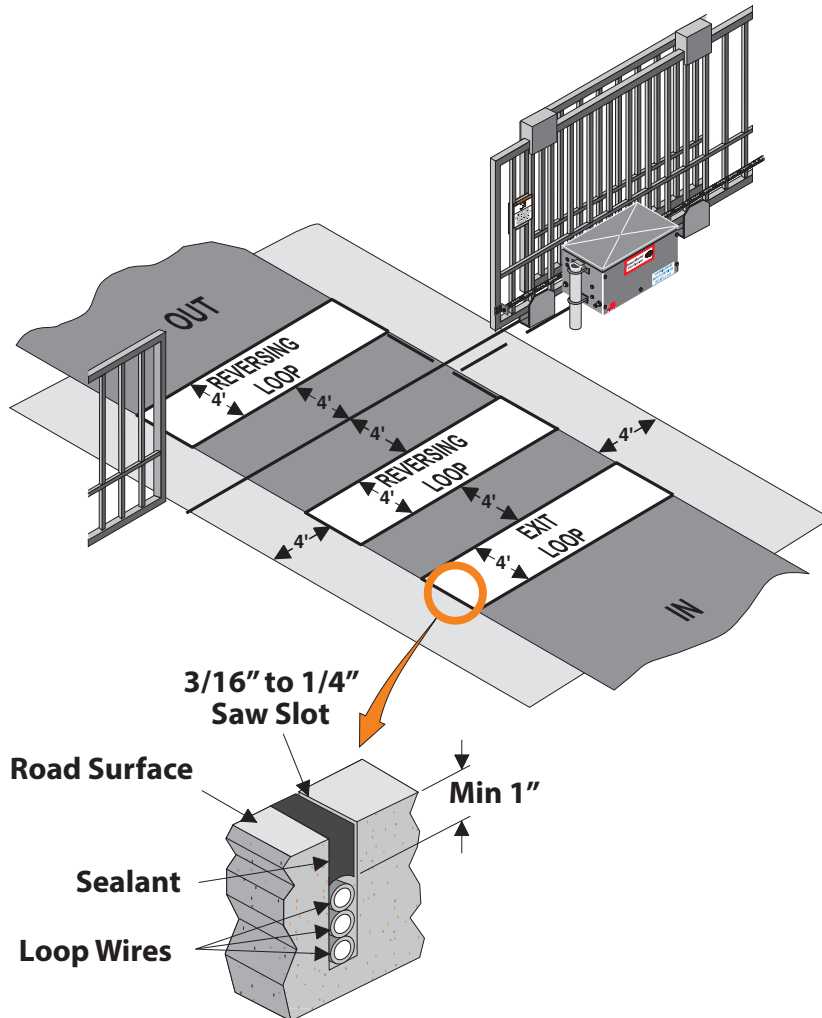

FIGURE 8

LOOP DETECTOR SYSTEMS AND INSTALLATION

The diagram below depicts the typical loop options for a Slide Gate installation.

1. The **Exit Loop** provides a signal to open the gate when a vehicle enters the loop zone.
2. The **Reversing Loop** protects a vehicle in the loop zone from being contacted with the gate by overriding any close signal while the gate is open, and by reversing the gate if closing.



LOOP INSTALLATION

1. Lay out the desired loop locations per the diagram. The standard size chart on the following page will give an approximate length of wire required for various loop dimensions and number of turns required.

NOTE: Length of lead-in wires must be added to loop lengths for total length of wire required.

CAUTION: The loop wires and lead-in wires must be a continuous piece of wire without splices. Only use wire intended for this type of application (Type XHHW insulation 16AWG).

NOTE: Buried steel from drains or other systems may affect functioning of the loop system. Check with the factory for advice on any special installations. Call 1-800-243-4476.

STANDARD LOOP LAYOUTS FOR APPROX. 36" HEIGHT DETECTION

LOOP SIZE	# OF TURNS	LOOP WIRE LENGTH (FT)
4' X 4'	4	64'
4' X 6'	4	80'
4' X 8'	3	72'
4' X 10'	3	84'
4' X 12'	3	96'
4' X 14'	3	108'
4' X 16'	3	120'
4' X 18'	3	132'
4' X 20'	3	144'
4' X 22'	3	156'
4' X 24'	3	168'
4' X 26'	3	180'
4' X 28'	3	192'
4' X 30'	2	136'
4' X 32'	2	144'
4' X 34'	2	152'
4' X 36'	2	160'
4' X 38'	2	168'
4' X 40'	2	176'

- Cut the required groove at the locations laid out in **Step#1** according to the diagram below (**Figure 9**).

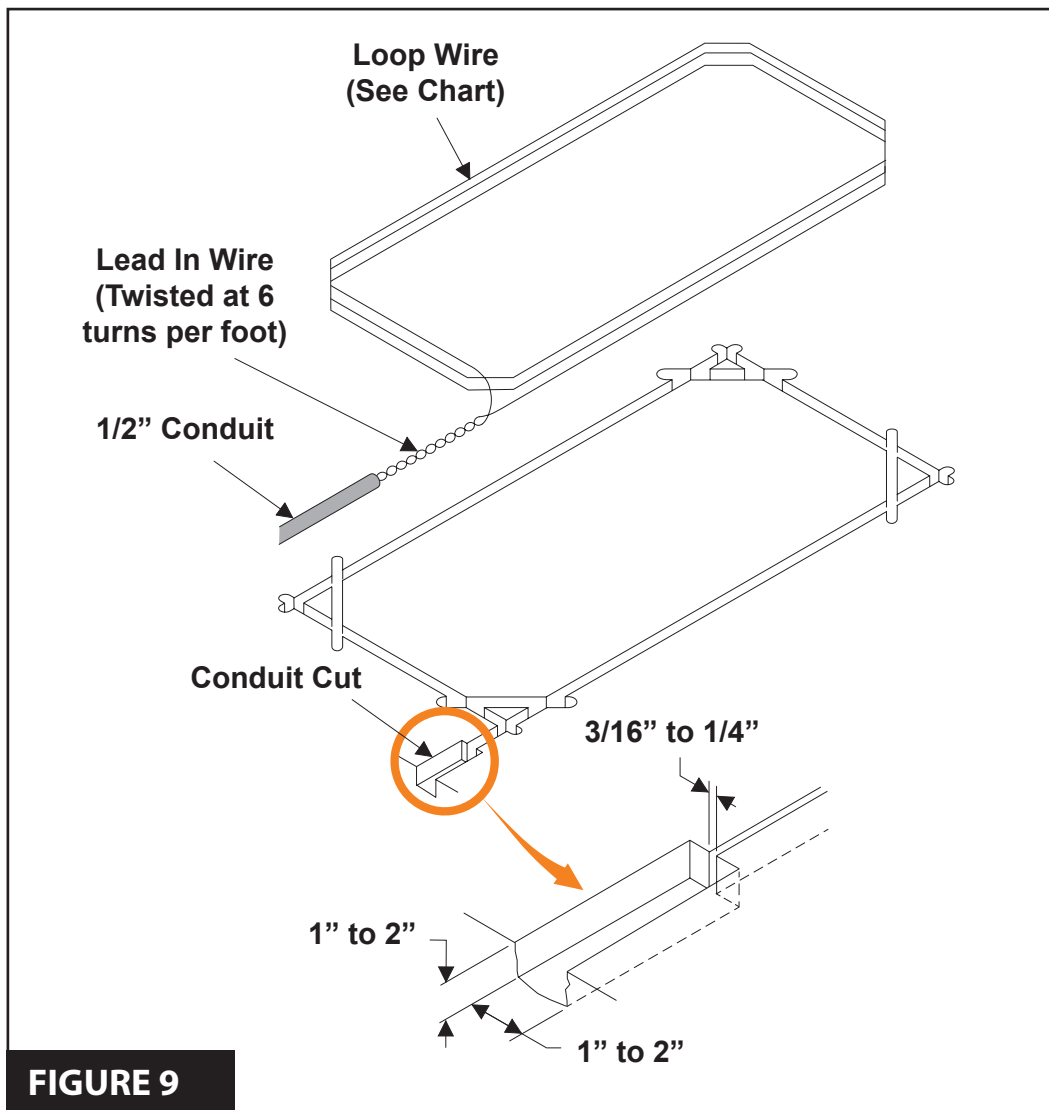

FIGURE 9

- Leaving enough wire for the lead-in, insert the specified number of turns of wire in the cut grooves (See chart).

CAUTION: Be careful not to damage the wire insulation during installation.

- After completing the required number of loop turns, twist the ends together at the rate of 6 turns per foot to form the lead-in.
- Seal the lead-in wire in the conduit to prevent moisture seepage into the conduit.
- Fill over the loop wires in the groove with a recommended loop sealant. Contact your distributor for available sealants.
- Mount the loop detector in the operator and connect the wire loop.
- Connect loop detector to the operator terminal strips as shown in the following diagrams:

EXIT LOOP CONNECTION

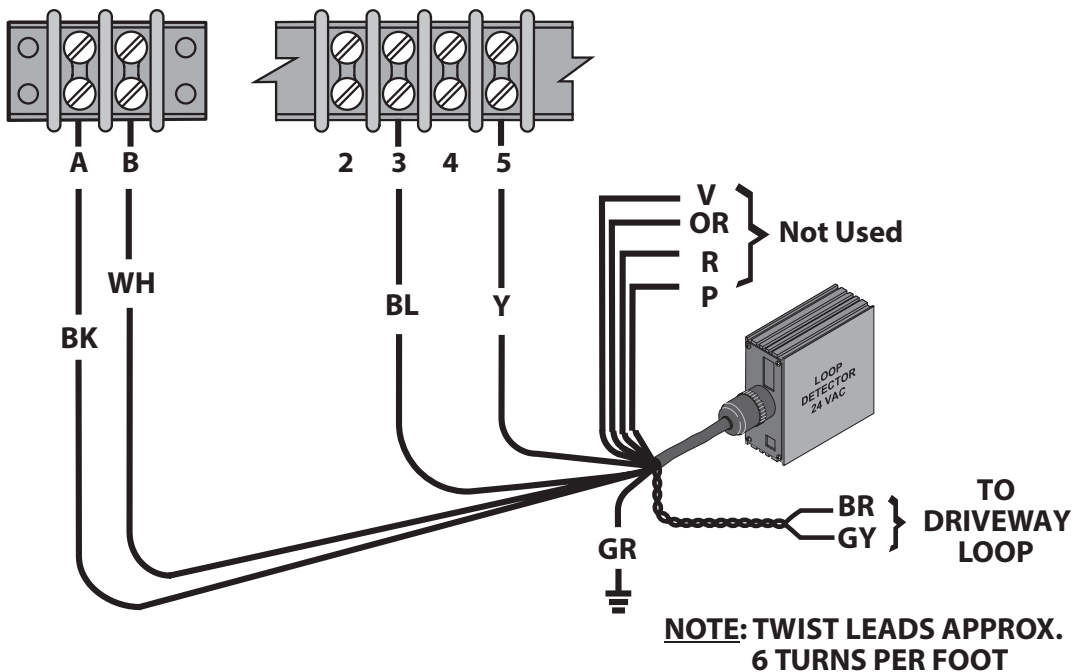

REVERSING LOOP CONNECTION

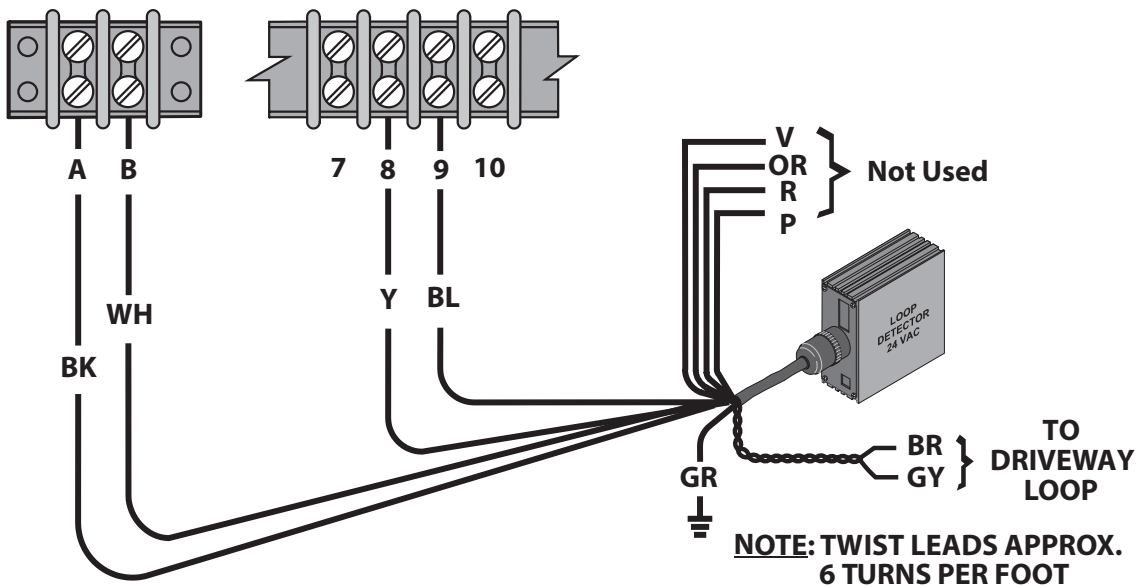

SAFETY DEVICE CONNECTIONS

INHERENT OBSTRUCTION SENSING DEVICE

NOTE: The gate **MUST** move smoothly and easily in manual operation before attempting this adjustment.

This unit is supplied with a current sensing system, which will stop the gate when it encounters an obstruction, and then backs the gate off approximately 2 inches. If the gate is started again and a second encounter occurs before hitting a limit switch, the gate will stop and sound a warning signal. A constant pressure control will then be needed to start the gate.

 **WARNING**

TURN OFF POWER TO OPERATOR WHEN MAKING ANY ADJUSTMENTS!

 **WARNING**

NEVER INCREASE FORCE SETTING TO MAKE UP FOR A GATE THAT IS NOT MAINTAINED PROPERLY. THIS WILL DESENSITIZE THE OPERATION OF THE SAFETY SYSTEM.

This sensing system has sensitivity adjustments located on the printed circuit board. The force required to activate the system may be adjusted in both **OPEN** and **CLOSE** directions separately. Start at minimum and increase force setting until it is just over what is required to move the gate smoothly without any nuisance tripping.

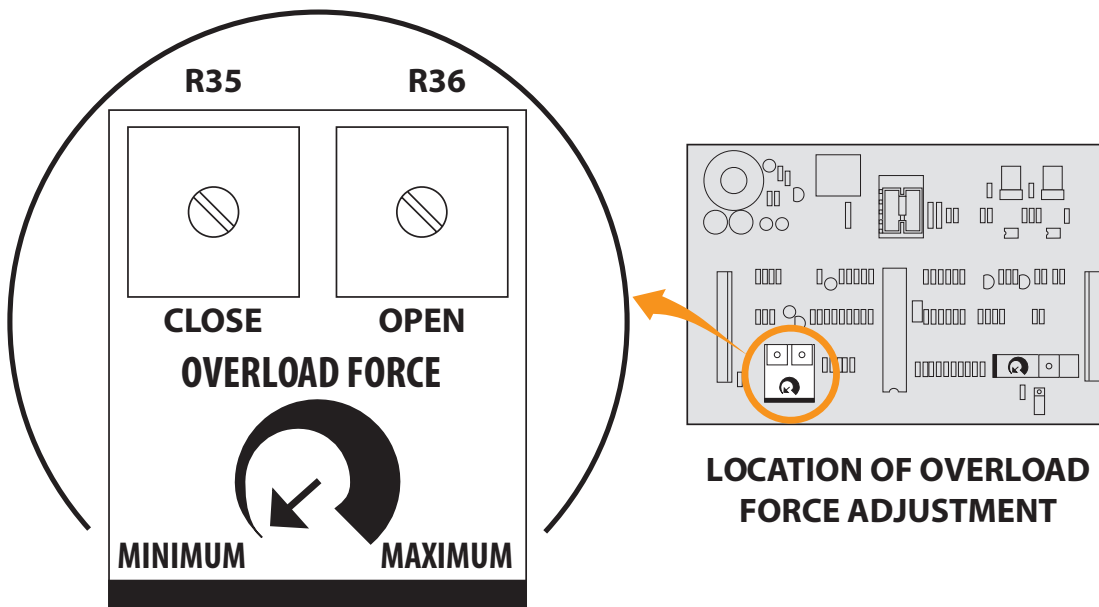

SECONDARY OBSTRUCTION SENSING DEVICES

Two sensing devices (either a contact or a non-contact system) must be installed and connected to this unit to increase protection against entrapment per UL requirements; one for each respective direction.

NOTE: Safety device contacts must be 10k monitored or NORMALLY OPEN.

NOTE: 24 VAC power is available at marked terminals for devices that may require it (e.g. photo eyes, wireless edges, etc.).

CONTACT SENSOR INSTALLATION

NOTE: Wireless sensors must be installed so there is no signal interference.

NOTE: All hard wiring to safety edges must be installed so there is no threat of mechanical damage to wiring between components when the gate is moving.

1. Install electric edge sensors in locations shown below.

NOTE: A separate pedestrian gate must be installed if there is no other entry access but the vehicular gate.

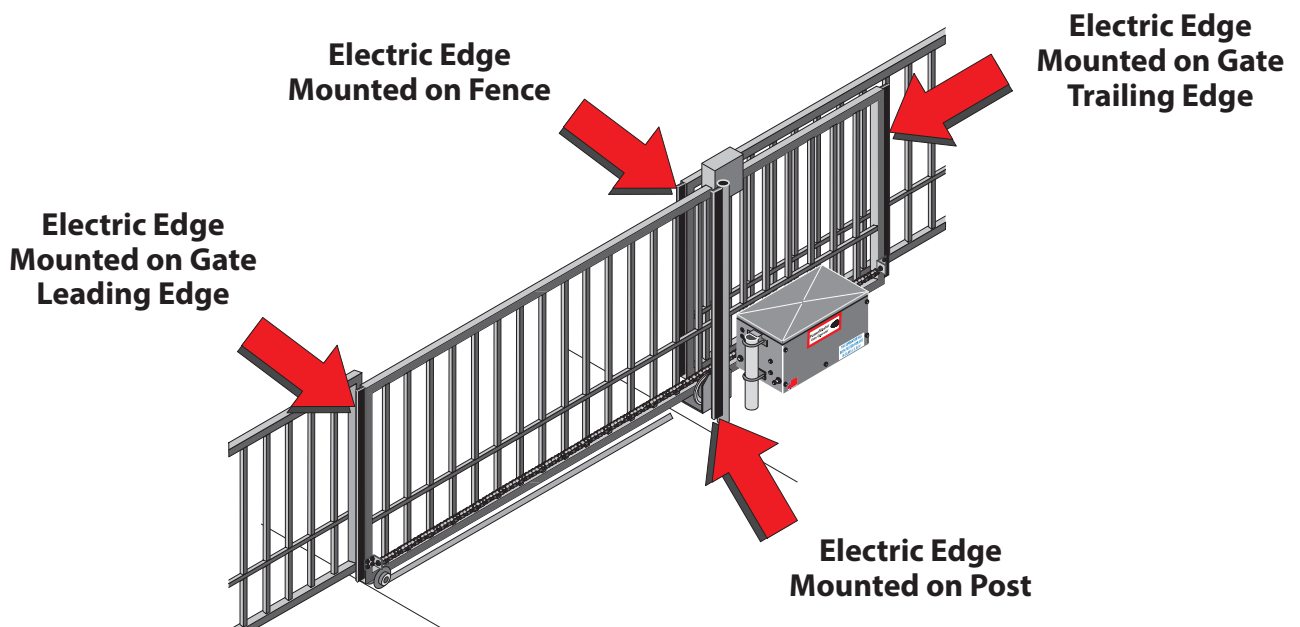

2. Connect contact sensor edges to the control board as shown in **Figure 10**.

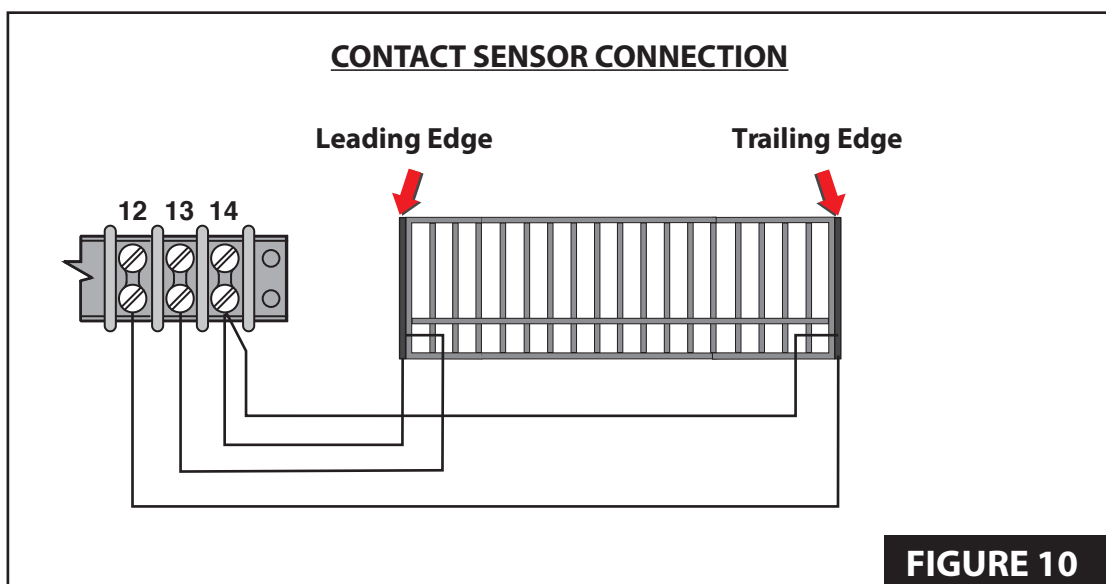

NOTE: Leading edge is connected to **Terminal #13** and **Terminal #14**. Trailing edge, Post Mounted Edge and Fence Mounted Edge are connected to **Terminal #12** and **Terminal #14**.

3. After sensors are mounted and electrically connected, turn **ON** the power.
4. Test the **CLOSE OBSTRUCTION SENSING SYSTEM** for proper operation by depressing the leading edge sensing strip while the operator is running closed.

NOTE: The operator should **STOP AND REVERSE** a short distance and then **STOP**.

5. Run the operator to the **CLOSE** limit.
6. Test the **OPEN OBSTRUCTION SENSING** system by depressing one of the other three edge sensors while the gate is opening.

NOTE: The operator should repeat the **STOP AND REVERSE** procedure.

7. Run operator to the **CLOSE** limit and repeat **Step #6** for the other two edges.

NON-CONTACT SENSOR INSTALLATION

1. Install photoelectric cell as close to inside of gate as possible.
2. Photocells should be installed across the gate opening and behind the gate at least 10 inches above ground (see image on right).

NOTE: A separate pedestrian gate must be installed if there is no other entry access but the vehicular gate.

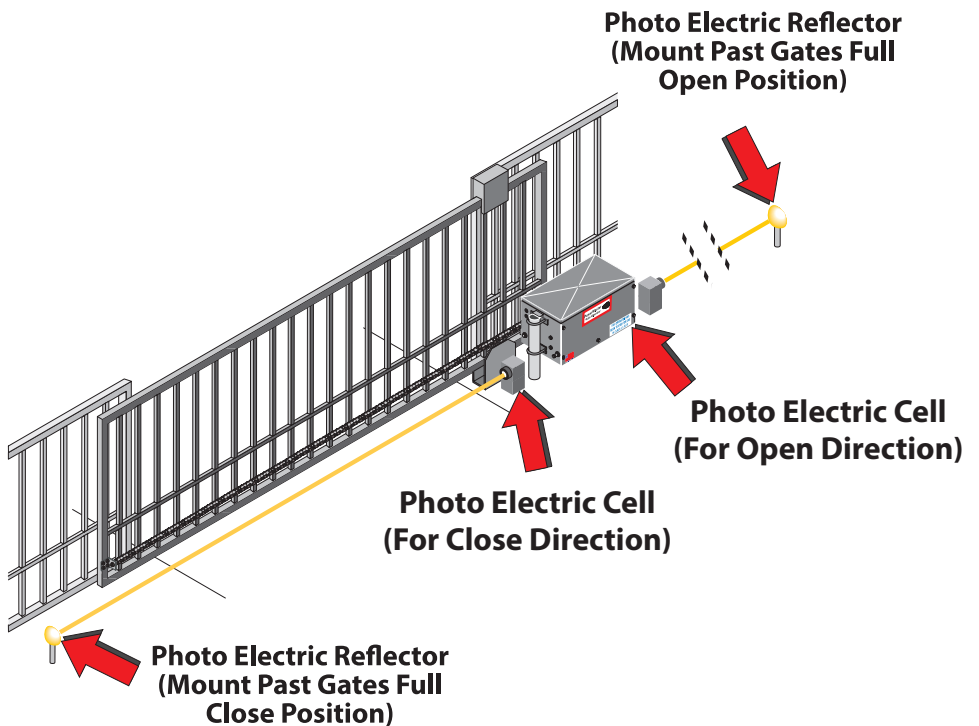

3. Connect **NON-CONTACT** sensors to the control board as shown in **Figure 11**.

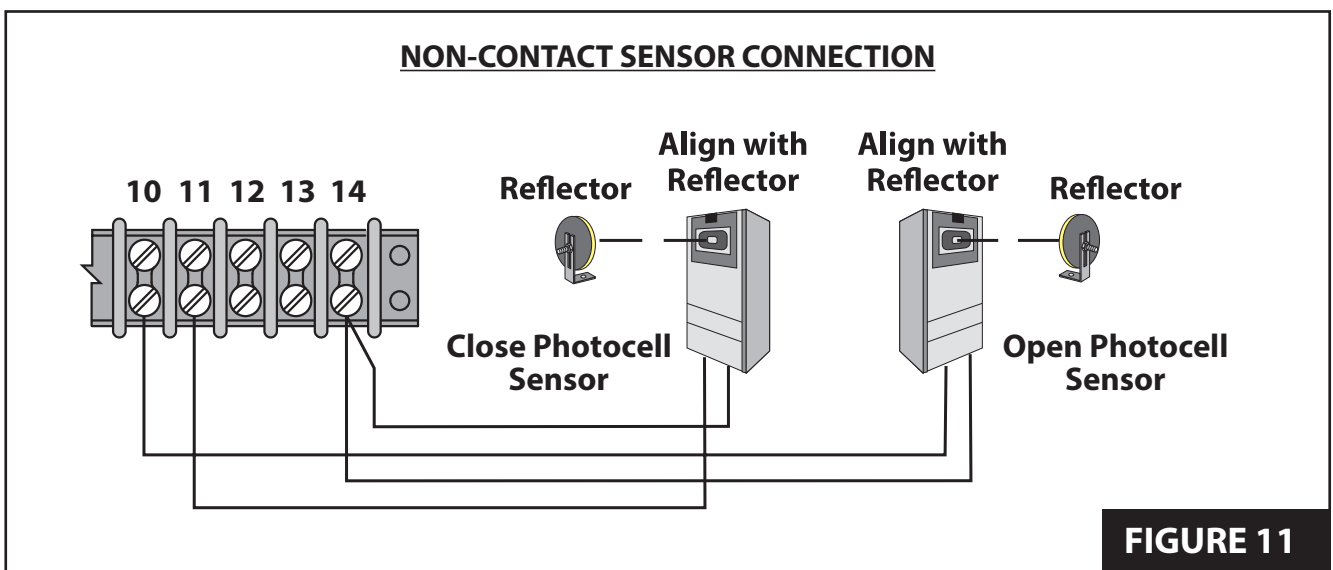

FIGURE 11

NOTE: Close photocell is connected to **Terminal #11** and **Terminal #14**. Open photocell is connected to **Terminal #10** and **Terminal #14**.

AFTER SENSORS ARE CONNECTED

1. Turn power **OFF**.
2. Make sure the photo-beams are properly aligned per the manufacturer's specifications.
3. Hold both limits.
4. Turn **ON** power.
5. Release limits after the beep turns off.
6. Test the **CLOSE OBSTRUCTION SENSING SYSTEM** for proper operation by blocking the beam across the gate opening while the gate is running closed.

NOTE: The gate should **STOP AND REVERSE** a short distance and then **STOP**.

7. Test the **OPEN OBSTRUCTION SENSING SYSTEM** by blocking the beam mounted at the back area of the gate while the gate is running open.

NOTE: The operator should repeat the **STOP AND REVERSE** procedure.

MAINTENANCE SUGGESTIONS

Lubricate the drive chain and idler sprockets, shaft bearings, internal drive chain, and disconnect slide every 3 months with 30-weight oil. Every 6 months, check drive belt for proper tension and signs of wear. Periodically check all hardware (nuts, bolts, screws, etc) for tightness.

PowerMaster

Limited 5-Year Warranty

PowerMaster warrants all GATE OPERATORS (Swing, Slide, Barrier categories) to be free of defects in materials and workmanship for a period of five (5) years from date of manufacture, provided that product has been registered. A one year warranty applies if product has not been registered.

ELECTRICAL PARTS (including boards, switches, relays, etc):

PowerMaster warrants electrical parts for a two (2) year period, provided that product has been registered. A one year warranty applies if product has not been registered.

If any part is found to be defective during this period, new parts will be furnished free of charge. Failure of this product due to misuse, improper installation, alterations, vandalism, acts of God, or lack of maintenance is **not** covered under this warranty, and voids any other implied warranties herein.

PowerMaster is **not responsible** for any labor charges incurred in connection with the installation of warranted parts.

In order to activate this warranty, the registration form found with your operator **MUST BE COMPLETED AND RETURNED WITHIN THIRTY CALENDAR DAYS FROM DATE OF PURCHASE**. Visit our website at www.PowerMasterNY.com and click on the **Register your Product** link.

You can also register via email to PMtech@PowerMasterNY.com.

If registration is not activated, a **ONE YEAR** warranty from date of manufacture will apply for all claims.

REGISTRATION INFORMATION

Operator Information

Model RSG

Serial # _____

Date Installed _____

Location Installed

Address _____

Address _____

Address _____

Installer's Information

Company Name _____

Address _____

Address 2 _____

City, State, Zip _____

Telephone # _____

Contact Name _____

The end user should retain this information for their records and to obtain warranty service.

Need Technical Support?

Visit: www.PowerMasterNY.com/faqs

Call us toll free @ 1-800-243-4476

Email us: PMtech@PowerMasterNY.com



www.facebook.com/PowerMasterOperators



Scan **QR Code**
with your Smart
phone to **find us**
on the web!

www.PowerMasterNY.com

 **powermaster**
MANUFACTURED BY V.E. POWER DOOR CO, INC.