

HSLG

INSTALLATION GUIDE

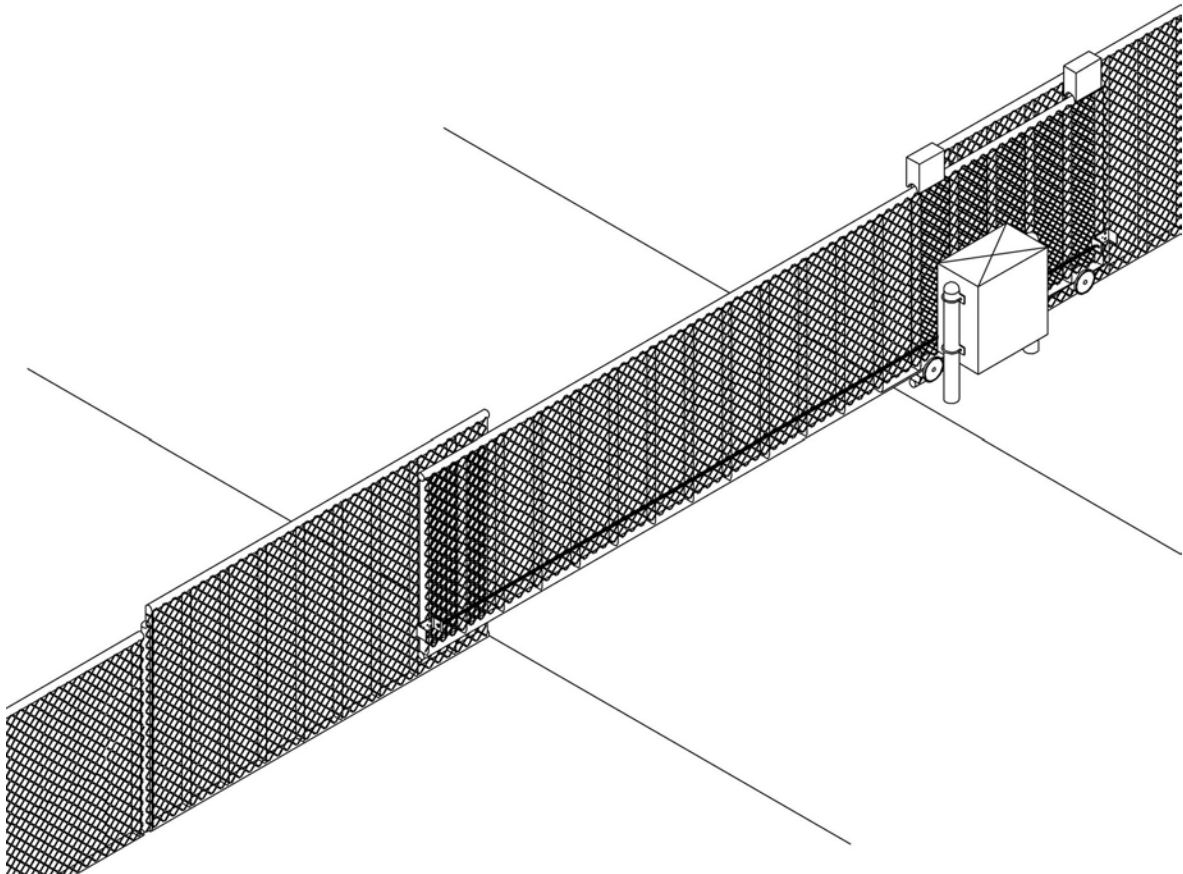

OSCO[®]

OPERATOR SPECIALTY COMPANY, INC.

CASNOVIA, MI 49318 • U.S.A.



**UL325 COMPLIANCE REQUIRES THE USE OF CONTACT EDGES
OR PHOTOELECTRIC CONTROLS ON ALL AUTOMATIC OR
REMOTELY-CONTROLLED GATE OPERATORS.**

HSLG OPERATOR INSTALLATION GUIDE

TABLE OF CONTENTS

PRE-INSTALLATION INFORMATION	
Gate Operator Classifications	3
Safety Information and Warnings	3
Pre-Installation Information	3
Warranty	3
INSTALLATION	
Wiring Specifications	4
Post Mounting Instructions	5
Gate Bracket and Chain Assembly Instructions	6
Torque Limiter Adjustments	7
Electrical Connection and Adjustments	8
Limit Nut Adjustments	8
CONTROL BOARD ADJUSTMENTS and ACCESSORY CONNECTIONS	
Control Board Adjustments	9
Terminal Connection Descriptions	10
Current Sensing Adjustments	11
Close Direction Current Sense Adjustment	11
Open Direction Current Sense Adjustment	11
Maximum Run Timer Adjustment	11
Auto Close Timer Adjustment	11
Master/Slave Connection	11
Onboard L.E.D. Indicator Descriptions	12
Important Notes for Installation of Master/Slave Applications	13
Surge Protector Instructions	13
Control and Accessory Connection Illustrations	14-17
ILLUSTRATIONS	
Loop Layout Illustration	18
Edge Layout Illustration #1	19
Edge Layout Illustration #2	20
Photo Eye Illustration	21
Picket Gate Illustration	22
Track Gate Illustration	23
TROUBLESHOOTING	24
PARTS LISTS	
How to Order Replacement Parts	24
Model HSLG Mechanical Parts Exploded View	25
Model HSLG Mechanical Parts List	26
Model HSLG Single Phase Control Box Exploded View and Parts List	27
Model HSLG Three Phase Control Box Exploded View and Parts List	28
PREVENTATIVE MAINTENANCE	29
GATE OPERATOR INSTALLATION CHECKLIST	30

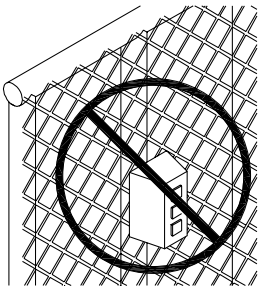

CAUTION!
DO NOT INSTALL
CONTROLS ON A
GATE OR FENCE LINE

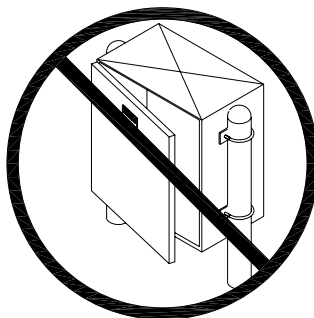

CAUTION!
ONLY QUALIFIED SERVICE
TECHNICIANS SHOULD
WORK ON AN OSCO
SLIDE GATE OPERATOR

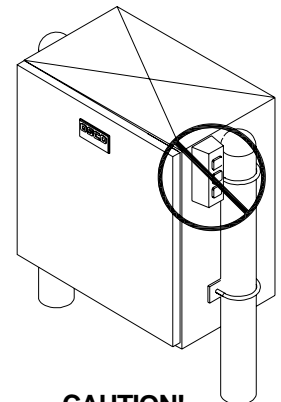

CAUTION!
DO NOT INSTALL
CONTROLS
ON THE OPERATOR

HSLG OPERATOR INSTALLATION GUIDE

GATE OPERATOR CLASSIFICATIONS

All gate operators can be divided into one of four different classifications, depending on their design and usage.

Class I: Residential

A vehicle gate operator (or system) intended for use in a home of one to four single-family dwellings, or a garage or parking area associated therewith.

Class II: Commercial or General Public Access

A vehicular gate operator (or system) intended for use in a commercial location or building such as a multi-family housing unit (five or more single-family units), hotel, garage, retail store, or other building servicing the general public.

Class III: Industrial or Limited Access

A vehicular gate operator (or system) intended for use in an industrial location or building such as a factory or loading dock area or other locations not intended to service the general public.

Class IV: Restricted Access

A vehicular gate operator (or system) intended for use in a guarded industrial location or building such as an airport security area or other restricted access locations not servicing the general public, in which unauthorized access is prevented via supervision by security personnel.

IMPORTANT ! !

Before installing the gate operator, make sure the gate's slide is free and level throughout the entire opening distance. If the gate does not seem to operate properly, it may affect the operator performance or greatly shorten the life of the unit. The gate should be designed so that airflow through the fabric is ample to prevent wind resistance and drag.



SAFETY INFORMATION AND WARNINGS

Read the following before beginning to install OSCO slide gate operators:

1. Read the yellow "Safety Instructions" brochure enclosed with the packet of information. If you do not have one, please call OSCO at 1-800-333-1717 to request one. Read and follow all instructions.
2. All electrical connections to the power supply must be made by a licensed electrician and must observe all national and local electrical codes.
3. A separate power-disconnect switch should be located near the operator so that primary power can be turned off when necessary.
4. Install the enclosed warning signs on both sides of the gate. Each sign must be plainly visible from the side of the gate on which they are mounted.
5. Never reach between, through or around the fence to operate the gate.
6. You must install all required safety equipment.

PRE-INSTALLATION INFORMATION

Before unpacking, inspect the carton for exterior damage. If you find damage, advise the delivery carrier of a potential claim.

Inspect your package carefully. You can check your accessory box parts with the enclosed packing slip for your convenience. Claims for shortages will be honored for only 30 days from the date of shipment.

Before installing the operator, read this manual completely to ensure all requirements for proper installation are present. Verify that the voltage to be used matches the voltage of the operator.

The following contact or non-contact obstruction detection devices have been approved for use with OSCO slide gate operators as part of a UL325 compliant installation:

Contact Edges:

Miller Models*: MG0-20, MGR-20, MGS-20, and ME-120

Photoeyes:

2520-441 MMTC Model IR-55 photoeye, 165' with mounting hardware

2520-031 MMTC Model E3K photoeye, 28' with mounting hardware

**for OSCO part numbers, contact a sales representative for details*

HSLG OPERATOR INSTALLATION GUIDE

WIRING SPECIFICATIONS

- Select from the chart at the bottom of this page corresponding to the model, voltage and horsepower rating of your operator.
- The distance shown on the chart is measured in feet from the operator to the power source. **DO NOT EXCEED THE MAXIMUM DISTANCE.** These calculations have been based on standard 115V and 230V supplies with a 10% drop allowable. If your supply is under the standard rating, the runs listed may be longer than what your application will handle, and you should not run wire too near the upper end of the chart for the gauge of wire you are using.
- When large-gauge wire is used, a separate junction box (not supplied) may be needed for the operator power connection.
- All control devices are now 24VDC, which can be run considerable distances. 24VAC is available for other devices, such as loop detectors and photo eyes.
- Wire run calculations are based on the National Electrical Code, Article 430 and have been carefully determined based on motor inrush, brake solenoids, and operator requirements.
- Connect power in accordance with local codes. **The green ground wire must be properly connected.**
- Wire insulation must be suitable to the application.
- Control wiring must be run in a separate conduit from power wiring. Running them together may cause interference and faulty signals in some accessories.
- Electrical outlets are supplied in all 115VAC models for convenience with occasional use or low power consumption devices only. If you choose to run dedicated equipment from these devices, it will decrease the distance for maximum run and the charts will no longer be accurate.
- A three-wire shielded conductor cable is required to connect master and slave operators. You must use Belden 8760 Twisted Pair Shielded Cable (or equivalent) **only** – OSCO part number 2500-1982, per foot. See page 9 for details of this connection, as well as dip switch selection. **Note: The SHIELD wire should be connected in both the master and slave operators.**

USE COPPER WIRE ONLY!

MODEL HSLG – SINGLE PHASE

Power Wiring											
Volts & HP	Max Distance		Wire Gauge	Volts & HP	Max Distance		Wire Gauge	Volts & HP	Max Distance		Wire Gauge
	Single	Dual			Single	Dual			Single	Dual	
115V	222	111	12	208V	760	380	12	230V	894	447	12
	354	177	10		1200	600	10		1422	711	10
	566	283	8		1924	962	8		2264	1132	8
1/2 HP	900	450	6	1/2 HP	3060	1830	6	1/2 HP	3600	1800	6
	1430	715	4		4864	2432	4		5724	2862	4
115V	178	89	12	208	604	302	12	230V	710	355	12
	282	141	10		958	478	10		1128	564	10
	450	225	8		1526	763	8		1796	898	8
3/4 HP	716	358	6	3/4 HP	2424	1212	6	3/4 HP	2852	1426	6
	1140	570	4		3856	1928	4		4538	2269	4
115V	160	80	12	208V	544	272	12	230V	640	320	12
	254	127	10		864	432	10		1016	508	10
	406	203	8		1374	686	8		1616	808	8
	646	323	6		2184	1092	6		2570	1285	6
1HP	1026	513	4	1HP	3476	1738	4	1HP	4090	2045	4

ACCESSORY WIRING

All Models		
Volts	Maximum Distance (ft.)	Wire Gauge
24VAC	250	14
	350*	12
24VDC	0-2000	14
*Over 350 ft. use DC power.		

MODEL HSLG – THREE PHASE

Power Wiring: 3 Phase											
Volts & HP	Max Distance		Wire Gauge	Volts & HP	Max Distance		Wire Gauge	Volts & HP	Max Distance		Wire Gauge
	Single	Dual			Single	Dual			Single	Dual	
208V 1/2 HP	1142	571	12	230V	1344	672	12	460V	3841	1921	12
	1816	908	10		2137	1069	10		6106	3053	10
	2890	1445	8		3400	1700	8		9712	4856	8
208V 3/4 HP	920	460	12	230V	1084	542	12	460V	3279	1640	12
	1464	732	10		1723	862	10		5212	2606	10
	2330	1165	8		2741	1371	8		8291	4146	8
208V 1HP	714	357	12	230V	840	420	12	460V	2689	1345	12
	1136	568	10		1336	668	10		4274	2437	10
	1804	902	8		2124	1062	8		6798	3399	8

HSLG OPERATOR INSTALLATION GUIDE

POST MOUNTING INSTRUCTIONS FOR MODEL HSLG

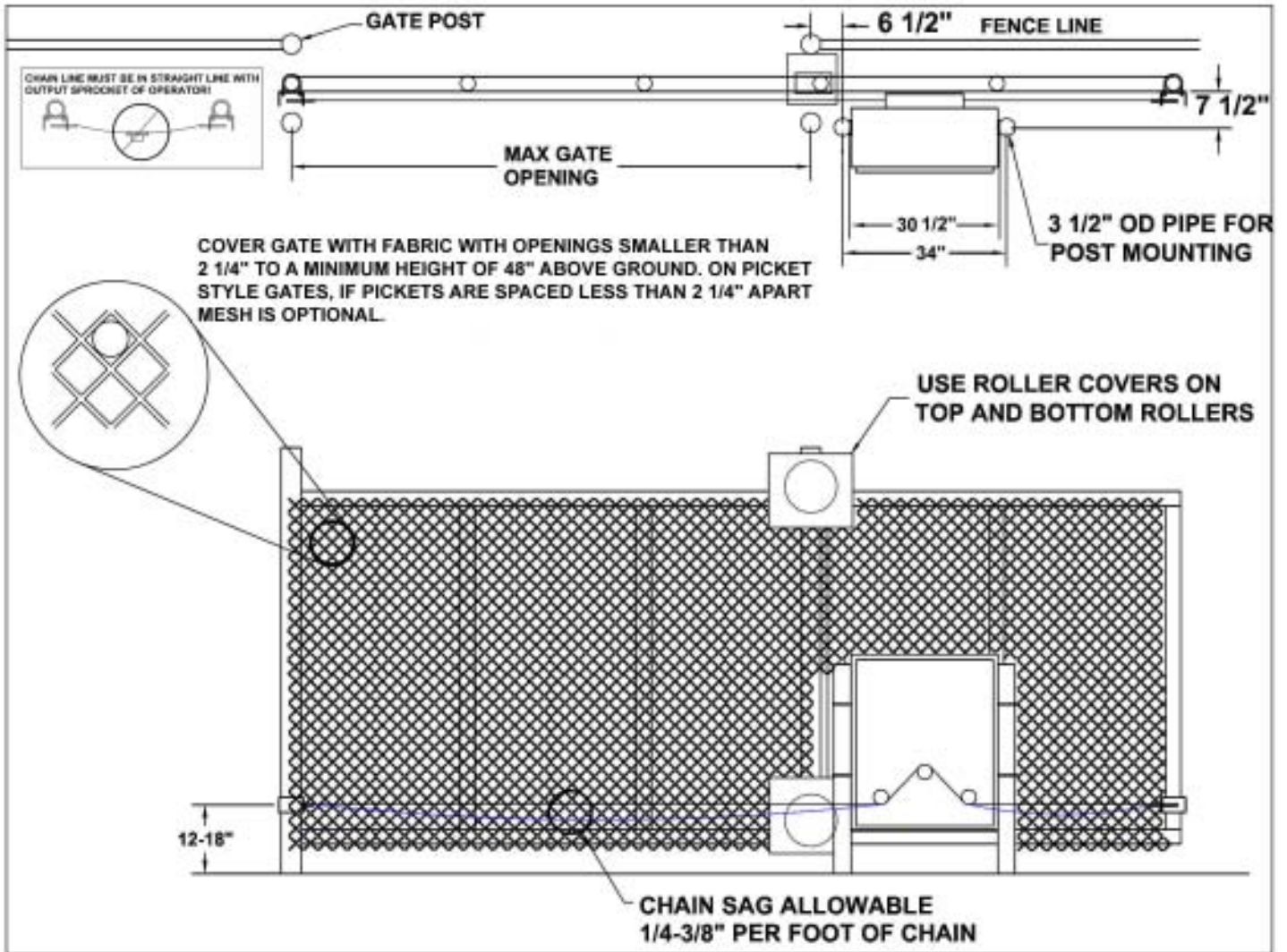

Before installing, make sure the gate rolls or slides freely, and that all exposed rollers are properly covered. The gate must be covered with fabric with openings no larger than 2 1/4" in size, to a minimum height of 48 inches from ground level. On picket-style gates, if pickets are spaced less than 2 1/4" apart, mesh is optional.

Use two 3 - 3 1/2" OD galvanized posts and secure with concrete footings as shown, length to be determined by local codes, frost line depth and soil conditions. Secure the operator to the posts using the 4" U-bolts, side plates, and hardware. There are a total of eight side plates. There are six 3/16" side plates which should be mounted on the outside top and bottom of the cabinet, two 3/16" side plates which go on the top inside and two 1/2" side plates which should be mounted on the inside top of the cabinet as shown in the illustration at the right.

To assemble the drive chain and gate brackets, refer to page 6. Make sure that the chain sag does not exceed recommended sizes and that the chain does not come into contact with the moving parts of the gate or ground.

For optional pad mounting instructions, see OSCO drawing #2700-360.

A SEPARATE PEDESTRIAN GATE IS REQUIRED FOR ALL PEDESTRIAN TRAFFIC. THIS GATE MUST BE A MINIMUM DISTANCE OF 7 FEET FROM THE VEHICULAR GATE AND GATE OPERATOR

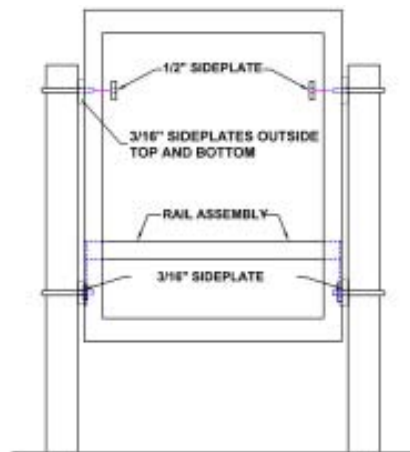

SIDE PLATE INSTALLATION

HSLG OPERATOR INSTALLATION GUIDE

GATE BRACKET AND CHAIN ASSEMBLY INSTRUCTIONS

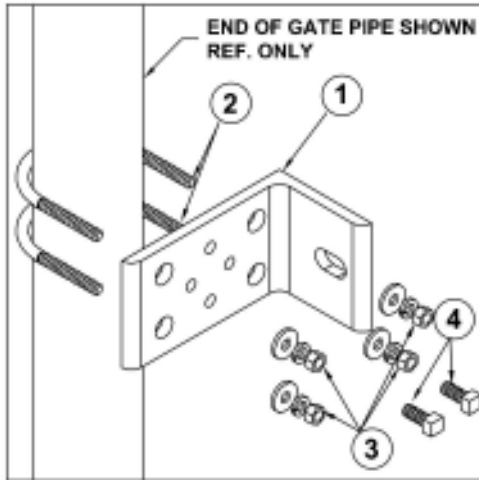

Numbered items in these drawings are for instructional reference only. For actual part numbers, go to the parts lists in the back of this booklet.

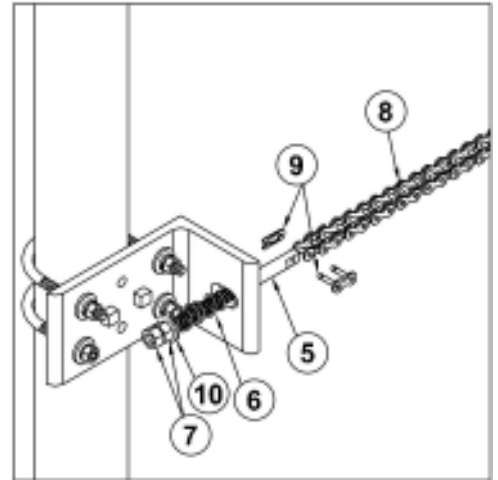

NOTE: IDLER CONFIGURATION MAY APPEAR DIFFERENT DEPENDING ON SLIDE OPERATOR MODEL.

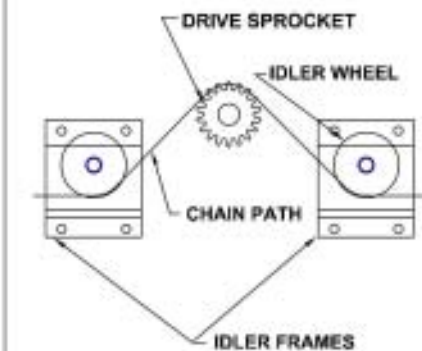

SOME MODELS MAY APPEAR MORE LIKE THIS:

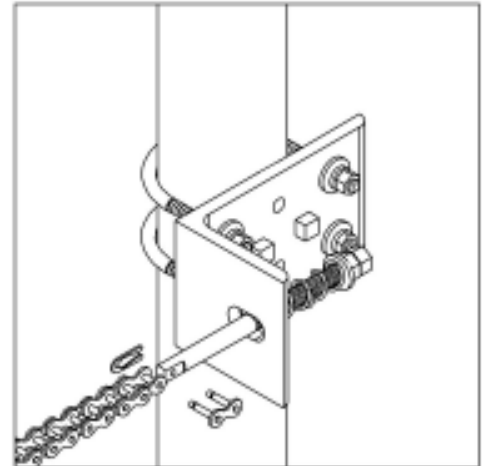
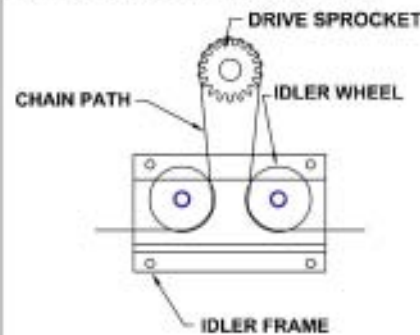

Assemble a gate bracket (1) to the front edge of the gate, using two U-bolts (2), and mounting hardware (3). Before tightening down completely, be sure the bracket is parallel to the gate. Tighten the U-bolt hardware the rest of the way, then screw the square head bolts (4) into the threaded holes in the gate plate until they bottom out against the gate. These will help keep the bracket from twisting on the pipe.

Slide a threaded chain pin (5) through the bracket as shown, with spring (6), flat washer (10), and two hex nuts (7). Attach one end of the drive chain (8) to the chain pin using master link (9) and begin unrolling it toward the operator.

Remove the rain cover from the back of the slide gate operator. Carefully thread the drive chain under the first idler, over the drive sprocket, and then under the last idler. Make sure you feed most of the chain through the sprockets for attaching to the back end of the gate.

Assemble the other gate bracket on the rear edge of the gate, using the same process as you did with the front gate bracket. Once this is done, take the other chain pin, spring and jam nuts and assemble with the end of drive chain and the other master link.

At this point you should be able to adjust the chain tension by tightening the jam nuts on each end. Approximately 1/4" to 3/8" of slack per foot of drive chain is acceptable. Make sure the chain does not drag on the ground, across the gate rollers or the idler frame of the operator.

Additional mounting holes have been provided in the gate bracket for installer convenience.

HSLG OPERATOR INSTALLATION GUIDE

TORQUE LIMITER ADJUSTMENTS

Before adjusting the torque limiter, make sure the gate is in good working condition. One person should be able to move the gate by hand. Be certain the gate moves freely and without binding throughout its travel. Torque limiters are set light at the factory and must be adjusted during installation. Adjust the torque limiter tight enough to keep it from slipping during normal operation.

To adjust the torque limiter in model HSLG:

1. Loosen the jam nut.
2. *To increase the output*, turn the adjustment nut clockwise one flat, or 1/6 turn, at a time until desired output is obtained.
To reduce the output, turn the adjustment nut counterclockwise one flat, or 1/6 turn, at a time until desired output is obtained.
3. Tighten the jam nut against the adjustment nut when finished.

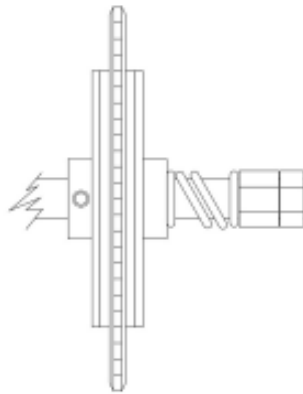

MODEL HSLG

HSLG OPERATOR INSTALLATION GUIDE

ELECTRICAL CONNECTION AND ADJUSTMENTS



**Power supply must be of correct voltage and phase.
Always disconnect power from operator before servicing.
Keep clear of gate during operation.**

All OSCO gate operators are supplied with a power disconnect switch to turn on and off the power supply available to the operator. Incoming power should be brought into the operator and connected to the labeled pigtails in the disconnect box following wiring specifications on page 4. A wiring connections print can be found on the inside cover of the operator.

Proper thermal protection is supplied with the operator. The motor contains a thermal overload protector to protect from overheating the motor due to overload or high-frequency operation. This overload will automatically reset after the motor cools down.

LIMIT NUT ADJUSTMENTS

The limit nuts are not preset at the factory and must be adjusted for the length of the gate the operator is installed on. The limit switches are activated by two threaded nylon rotary limit nuts which are attached to a threaded shaft and driven by chain and sprockets from the main drive shaft. Remove the cardboard filler before attempting to adjust the limit nuts.

With the gate connected to the gate operator in a mid-travel position, and the power disconnect switch turned **OFF**, disconnect the operator by using the manual disconnect lever. Instructions for the manual disconnect can be found in the individual operator owner's guides. Once the operator has been disconnected, manually move the gate by hand to within a foot of its fully open position (the foot of distance is necessary to allow for coasting of the operator after the limit switch is tripped).

Once the gate is in this position, adjust the open limit nut until it activates the limit switch for open, **LSO-1**. Press down on the detent plate and rotate the nut along the threaded shaft. Refer to the illustration below for additional details.

Once the open limit nut is set, repeat the above process for the close direction nut and the **LSC-1** limit switch.

After finishing the initial limit nut adjustments, reposition the gate to approximately its center of travel. Re-engage the operator and turn the power disconnect **ON**. Stand clear of any moving parts and press the **OPEN** button on the three-button station. If the gate begins to close instead of open, press the **STOP** button immediately. Find the dip switch block on the main control board and switch the hand of operation (dip switch #4, see page 9) and try to open the gate again. Observe the gate as it runs through a complete cycle in both directions, and adjust your limits again if necessary. Fine levels of adjustment can also be achieved by adjusting a few teeth on the nut at a time. If the gate stops in midtravel, the open or close current sensor adjustment or the maximum run timer may need adjustment (see page 11).

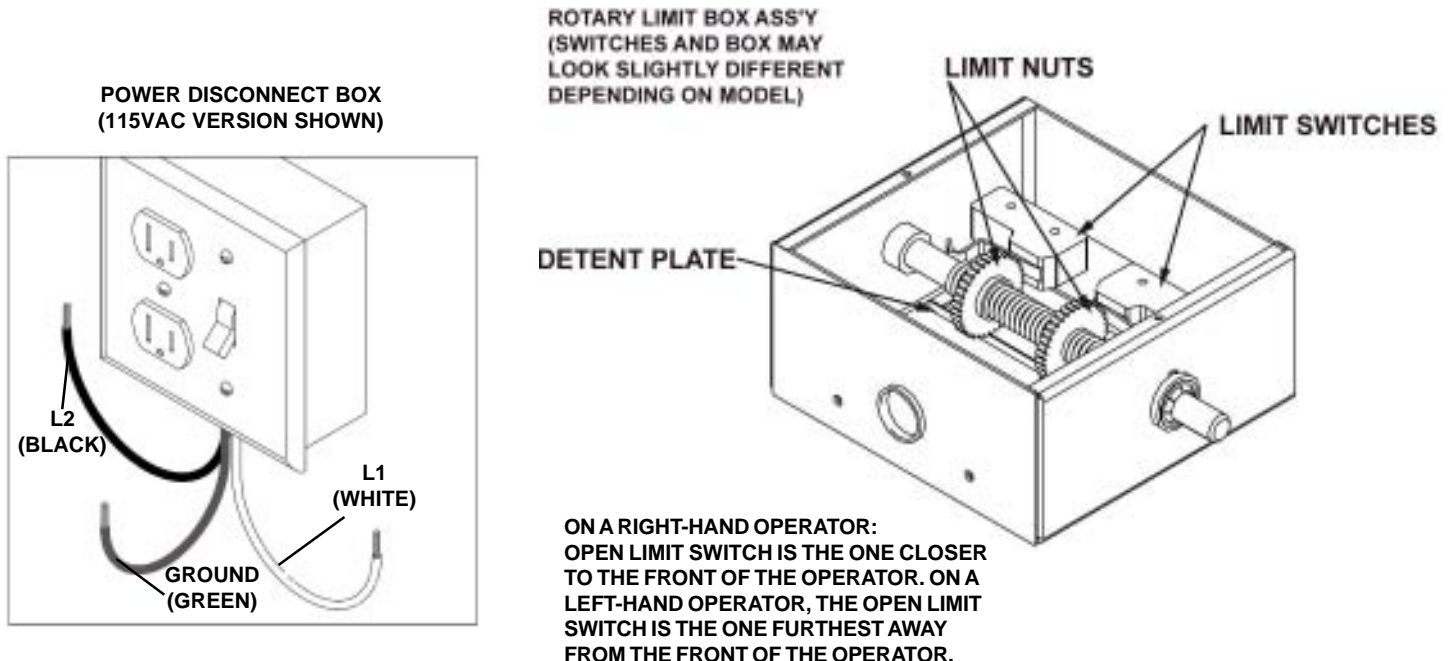

HSLG OPERATOR INSTALLATION GUIDE

CONTROL BOARD ADJUSTMENTS

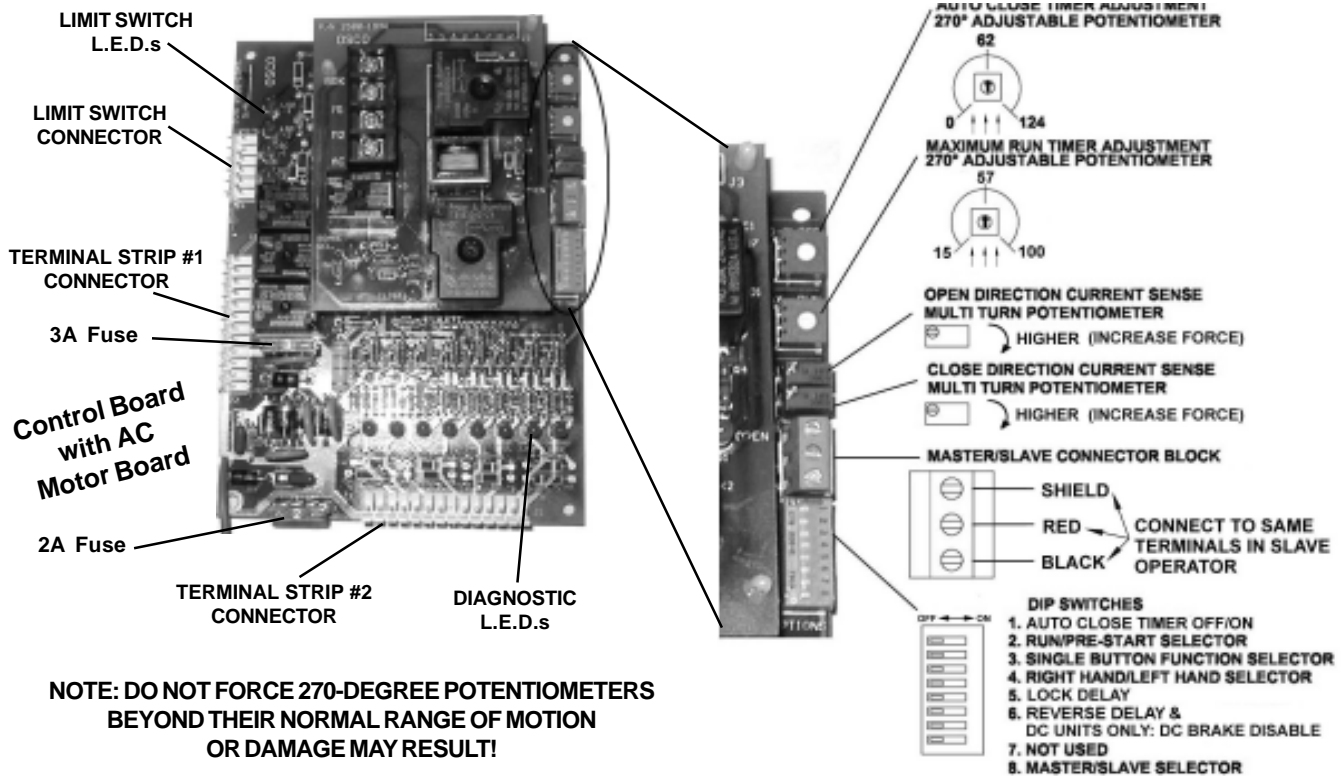

Auto Close Timer Adjustment: This 270-degree adjustable potentiometer will signal the operator to close automatically, provided no open, reversing or obstruction signals are present from the fully-open position. This timer is adjustable from 0 to 124 seconds. This feature is turned on or off using dip switch #1.

Maximum Run Timer Adjustment: This 270-degree adjustable potentiometer will signal the operator to stop running once it counts down, unless a limit switch is reached or an input is received first. Each time the motor starts, this timer will begin counting. This timer is adjustable from 15 to 100 seconds. If the timer expires, the unit locks out and the emergency alarm sounds.

Open Direction Current Sense Adjustment: This multiturn potentiometer is used to calibrate the built-in current sensing feature for detection of obstructions while running in the open direction.

Close Direction Current Sense Adjustment: This multiturn potentiometer is used to calibrate the built in current sensing feature for detection of obstructions while running in the closed direction.

Master/Slave Connection Block: This terminal block is used in conjunction with two operators to configure two gates to open and close together.

Dip Switches:

- #1 This switch turns the auto close timer off/on.
- #2 This switch is used in conjunction with alarms and flashing lights that may be added to the operator. When the switch is in the **ON** position, these devices will start approximately two seconds prior to the operator starting. In the **OFF** position, the devices will only work while the operator is running.
- #3 This switch is used in conjunction with single-button controls and radio receivers. In the **ON** position, successive inputs will cause signals in the order of **OPEN-STOP-CLOSE-STOP**. In the **OFF** position, inputs will cause an **OPEN** signal unless the gate is fully open, in which case it will signal **CLOSE**.
- #4 This switch determines right-hand vs. left-hand behavior. When looking from inside the protected area toward the gate, the side of the drive the operator is on determines its hand of operation. In the **OFF** position, the operator is set for right-hand.
- #5 When turned **ON**, this switch will allow a one-second delay for solenoid locks to unlock before the motor starts.
- #6 In the **ON** position, the reverse delay is three seconds. In DC operators only, this also disables the inherent DC brake (provided the R2 brake resistor is cut, see picture above). In the **OFF** position, the reverse delay is 1 1/2 seconds and the DC inherent brake is enabled.
- #7 Not used at this time.
- #8 This switch is used to set Master/Slave configuration. Operators which are stand-alone or master units should be set to **OFF**, while only slave units should have this switch set to **ON**.

HSLG OPERATOR INSTALLATION GUIDE

TERMINAL CONNECTION DESCRIPTIONS

TERMINALS	FUNCTION	DESCRIPTION OF FUNCTION
24VAC 24VAC N	24VAC	Provides 24Volt AC power for accessories. Note: DC models will NOT have 24Volt AC power available.
24VDC+ 24VDC- COMM.	24VDC	Provides 24Volt DC power for accessories.
1 & 4	OPEN	Opens the operator. Several accessories such as button stations, keypads, transmitters and card readers can be wired to open.
3 & 4	CLOSE	Closes the operator. Use caution when wiring accessories to these terminals. The gate must be clearly visible from the location of any accessories wired to close.
4 & 5	SINGLE-BUTTON	Performs the single-button function which will alternate between open and close or open, stop and close - depending on dip switch #3. (See page 9 for details.)
2 & 4	STOP	Stops the operator. If no stop button is used, a jumper is required across 2&4 .
4 & 6	REVERSE	This function will cause a reversal when the gate is traveling closed and will travel back to the fully open position. Loop detectors are often wired for reverse.
4 & 50	OPEN OBSTRUCTION	This function works only while the operator is opening. Any signal to this function will cause the gate to stop, reverse a short distance, and then stop again. At this time the auto close timer is disabled, and a renewed input will be required to start the gate again. Should the gate be restarted and the signal occur again prior to reaching a limit, the gate will stop again, and this time will sound the emergency alarm and lock out.
4 & 51	CLOSE OBSTRUCTION	This function works exactly like the OPEN OBSTRUCTION, except that it will only work in the closing direction.
4 & 11	SHADOW/HOLD	This function will keep the gate in its fully open position while the signal is present. This is typically used with a loop and loop detector to keep a large swing gate open while vehicular traffic is passing through.
24VDC+ & 60	RUN/PRE-START	A 24Volt DC device such as a strobe light or alarm can be wired to these terminals. Depending on dip switch #2, these devices will either begin three seconds before the operator starts, or only while the motor is running. (See page 9 for details.)

 **You must follow all required safety precautions and instructions at all times. Review the safety brochure included with the operator. If any pages are missing or unreadable, contact OSCO at 1-800-333-1717 to request additional copies.**

 **Never connect a button station within reach of the gate or on the side of the gate operator.**

 **Do not adjust the circuit board current sensing feature too high. It should be adjusted high enough to keep the gate from falsely triggering the sensing, but no higher than necessary for the gate to operate. Do not defeat the purpose of this function!**

HSLG OPERATOR INSTALLATION GUIDE

CURRENT SENSING ADJUSTMENTS

Because gates vary in construction and may have different force requirements in the open and close directions to move, the OSCO control board has separate Multi-turn potentiometers for adjusting in both directions independently. The adjustment should be set light enough to maintain minimal force (50-75 lbs.) should an obstruction occur, but high enough to keep the gate moving under normal conditions without interruption.

Prior to adjusting the operator current sensing functions, make sure the gate moves freely in both directions. A badly aligned or poorly maintained gate may cause false triggering of the current sensor. Refer to page 9 when following the instructions below. A factory adjustment tool has been supplied to make these adjustments easier. This tool has been taped to the control box for your convenience.

CLOSE DIRECTION CURRENT SENSE ADJUSTMENT

When the gate operator leaves the factory, it has been preset for a relatively light gate function and will require additional adjustment. Begin by starting the gate going closed. If the operator stops and reverses, turn the close direction potentiometer (see page 9) one turn higher, press the **STOP** button, and try again. Repeat this process until the gate no longer causes false tripping of the current sensor. Note that each time the gate operator reverses, the **STOP** button must be pressed. Next, turn the close direction potentiometer lower slowly while the operator is running the gate closed until the gate operator stops and reverses again. From this point, turn the close direction potentiometer higher by 1 1/2 turns for all 115 Volt AC and 24 Volt DC operators, and by 3/4 of a turn higher for all 230 Volt AC operators. Additional fine adjustment by 1/4 turns may be necessary to eliminate false triggering.

OPEN DIRECTION CURRENT SENSE ADJUSTMENT

Repeat the same process with the open direction potentiometer while running the gate in the open direction. Once this is done, run the gate through several complete cycles and make sure the gate does not false trip in either direction.

Multi-turn Potentiometer

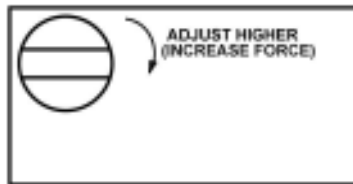

Remember it is important not to set the adjustment too high! Doing so will defeat the purpose of the current sensing as an obstruction detecting feature.

MAXIMUM RUN TIMER ADJUSTMENT

This adjustable potentiometer sets the maximum length of time the motor will run before shutting down. It should be configured for the time it takes to run the gate fully open or closed, plus an additional 15 seconds. See page 9 for details.

AUTO CLOSE TIMER ADJUSTMENT

This adjustable potentiometer sets the length of time which elapses before the gate operator automatically closes the gate, from the fully open position, provided no open, reversing, or obstruction signals are present. This feature can be turned on or off via dip switch selection. See page 9 for details. **Do not use the auto close timer without an appropriate reversing device installed!**

MASTER/SLAVE CONNECTION

A three-wire shielded conductor cable is required to connect master and slave operators. You must use Belden 8760 Twisted Pair Shielded Cable (or equivalent) **only** – OSCO part number 2500-1982, per foot). See page 9 for details of this connection, as well as dip switch selection. Note: The SHIELD wire should be connected in both the master and slave operators. **In addition, you must run power to both the master and slave operators.**

HSLG OPERATOR INSTALLATION GUIDE

ONBOARD L.E.D. INDICATOR DESCRIPTIONS

Control Board L.E.D. Indicators:

OPEN		This indicator is lit when an open signal is present. This signal can come from such devices as button stations, radio receivers, keypads and telephone entry systems.
CLOSE		This indicator is lit when a closed signal is present. This signal typically comes from three-button stations.
STOP		This indicator is lit when there is a break in the stop circuit. Make sure there is a stop button wired in and working properly.
SINGLE		This indicator is lit when a signal from a single-button station or radio receiver is present.
CLOSE OBST		This indicator is lit when a close obstruction signal is present. This signal can come from edges and photo eyes which have been wired to the close obstruction inputs.
OPEN OBST		This indicator is lit when an open obstruction signal is present. This signal can come from edges and photo eyes which have been wired to the open obstruction inputs.
SAFETY LOOP		This indicator is lit when a reversing signal is present. This signal is generated by a loop detector wired to the safety loop terminals.
SHADOW LOOP		This indicator is lit when a shadow/hold open signal is present. This signal is generated by a loop detector wired to the shadow loop terminals.
	<u>LH</u>	<u>RH</u>
LSC-1	LSO-1	This indicator is lit when the open #1 limit switch is activated on a right-hand operator, or the close #1 switch on a left-hand. If this indicator is lit and the gate is not in its full open/closed position, the limit may need adjusting or the limit switch may need replacing.
LSC-2	LSO-2	This indicator is lit when the open #2 limit switch is activated on a right-hand operator, or the close #2 switch on a left-hand.
LSO-1	LSC-1	This indicator is lit when the close #1 limit switch is activated on a right-hand operator, or the open #1 on a left-hand. If this indicator is lit and the gate is not in its full open/closed position, the limit may need adjusting or the limit switch may need replacing.
LSO-2	LSC-2	This indicator is lit when the close #2 limit switch is activated on a right-hand operator, or the open #2 switch on a left-hand.

Motor Board L.E.D. Indicators:

NON LABELED	One of these two indicators will be lit when the motor is running the gate open, and the other is lit when the motor is running the gate closed.
BRAKE REL.	This indicator is lit when the brake is NOT applied.

HSLG OPERATOR INSTALLATION GUIDE

IMPORTANT NOTES FOR INSTALLATION OF MASTER/SLAVE APPLICATIONS

When setting up Master/Slave gate operators, it is best to make adjustments and run each operator individually. To do this, simply:

- a. Set Dip Switch #4 to proper hand of operation (right-hand or left-hand)
- b. Set Dip Switch #8 as Master (off)

Run each operator making current sensing adjustments as necessary, as indicated on the Control Board Adjustments page of this installation guide. When both operators have been adjusted, turn power off, then turn on Dip Switch #8 in the operator chosen as the Slave.

The timer to close and radio/single button behavior are set in the Master operator.

The following selections are set individually:

- Current Sensing
- Maximum Run Timer
- One-Second Lock Release
- Three-Second Pre-Start Warning
- Right/Left-Hand Selections

SURGE PROTECTOR INSTRUCTIONS

The optional surge protector should be connected to any inputs that have an accessory connected to it. This includes the 3-button station, so it must be connected to 1, 2A and 3 in all cases. The green wire connected to ground, which is electrically the same as terminal 4. The red wires connect to terminals 2A and 24VDC+. This will cause the 2 amp fuse to blow if this section of the module becomes shorted. With any of the other inputs connected to the surge protector, if their protection line becomes shorted due to a surge over the rating of the module, the corresponding LED on the main board will remain lit, causing a constant signal to the controller. If this is found, please replace the entire surge protector with a new unit.

Do not simply unhook the shorted wire, as this removes the protection from the circuit that was saved by the protector in the first place!

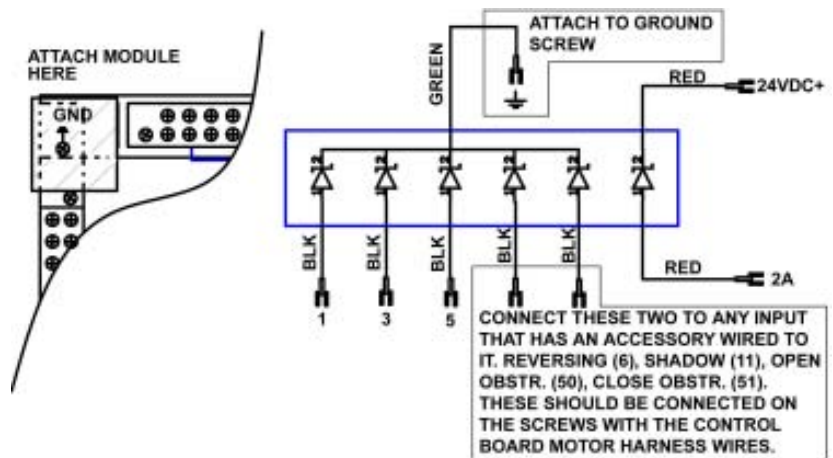

HSLG OPERATOR INSTALLATION GUIDE

CONTROL and ACCESSORY CONNECTION ILLUSTRATIONS

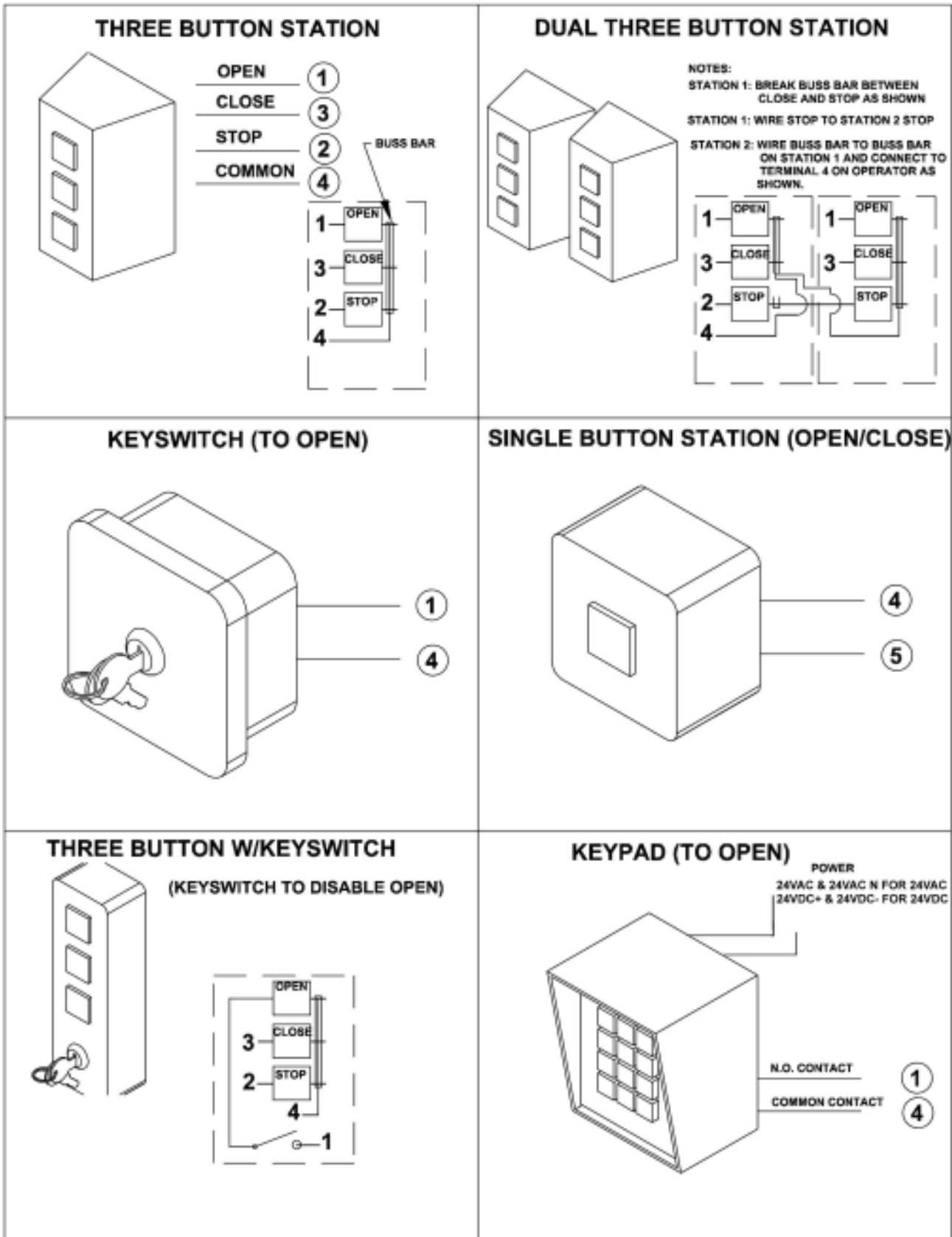

HSLG OPERATOR INSTALLATION GUIDE

CONTROL and ACCESSORY CONNECTION ILLUSTRATIONS

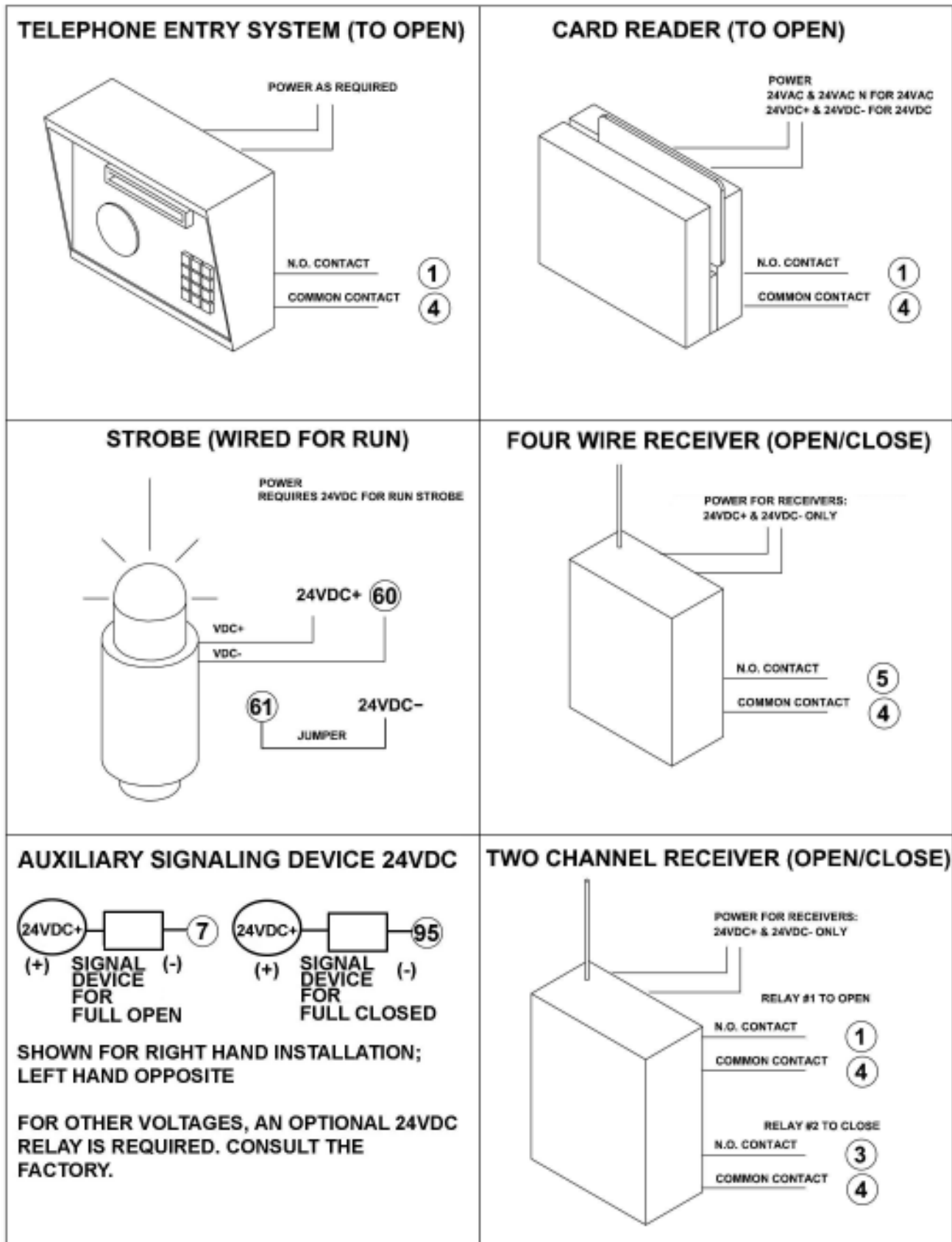

HSLG OPERATOR INSTALLATION GUIDE

CONTROL and ACCESSORY CONNECTION ILLUSTRATIONS

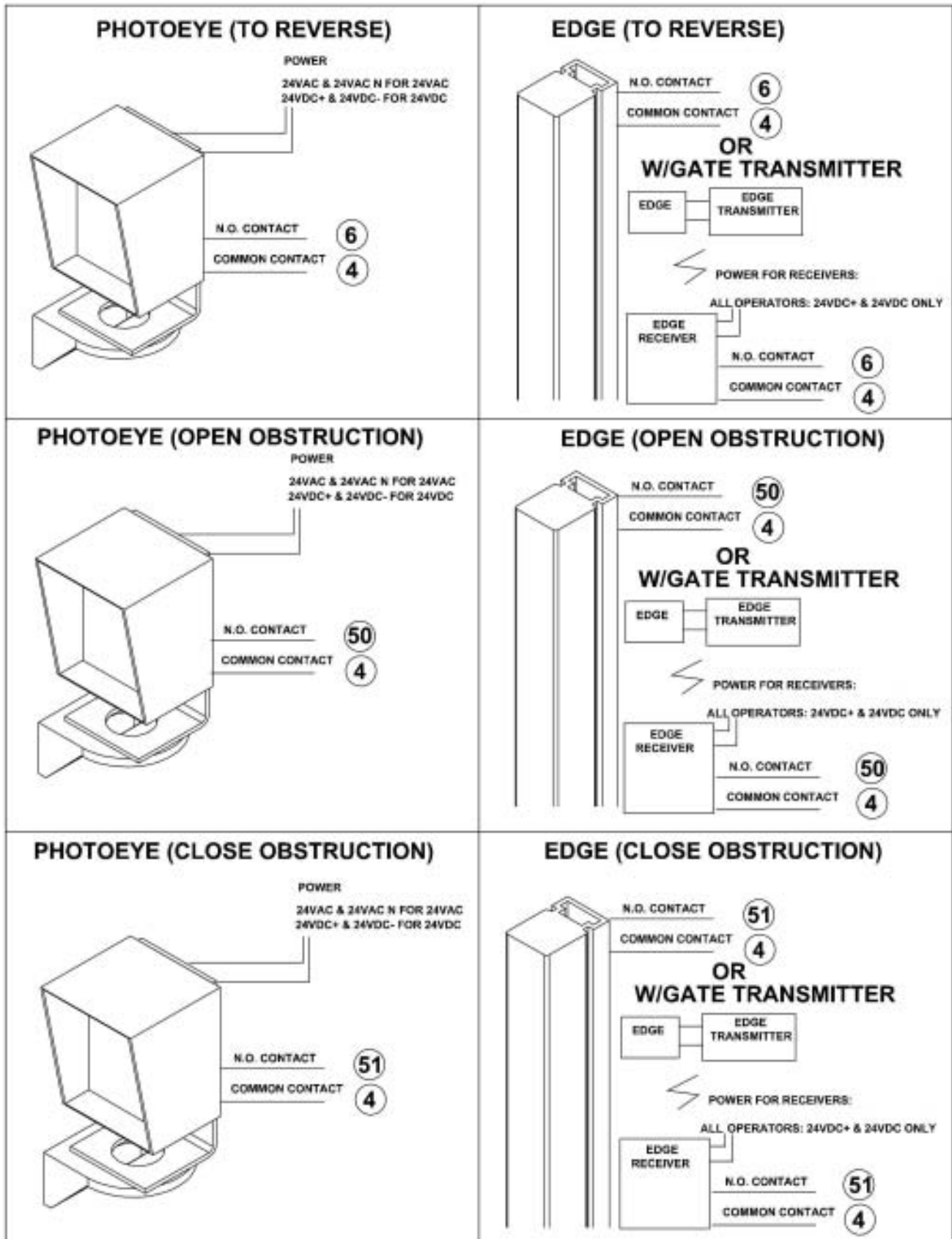

HSLG OPERATOR INSTALLATION GUIDE

CONTROL and ACCESSORY CONNECTION ILLUSTRATIONS

LOOP DETECTOR (OPEN/FREE EXIT)

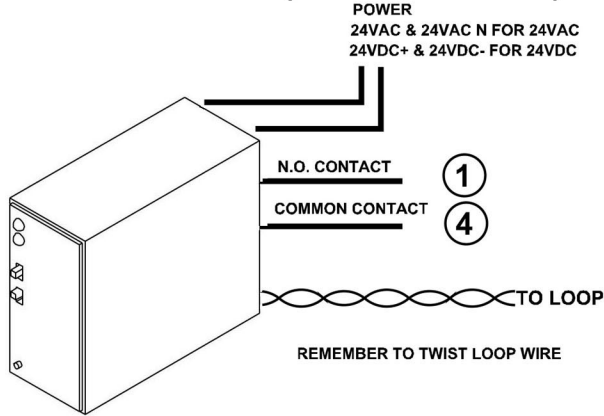

WIRES 17, 18, AND 19 ARE LOCATED IN THE MIDDLE OF THE J2 CONNECTOR

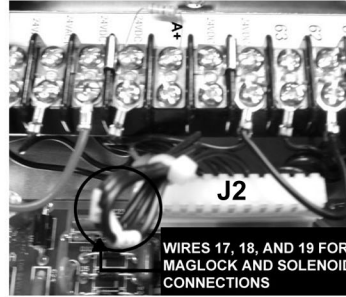

LOOP DETECTOR (TO REVERSE)

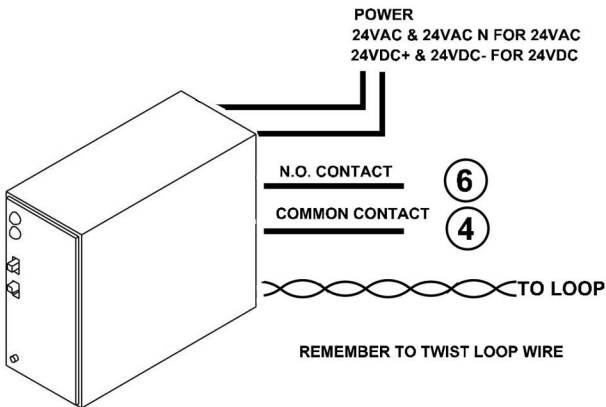

SOLENOID LOCK

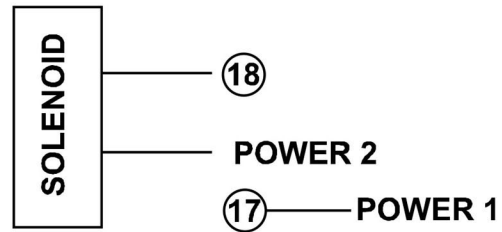

MAKE SURE TO MATCH POWER VOLTAGE TO LOCK RATING (17 & 18 ARE NORMALLY OPEN CONTACTS, 10 AMP RATING)

24VDC MAGLOCK

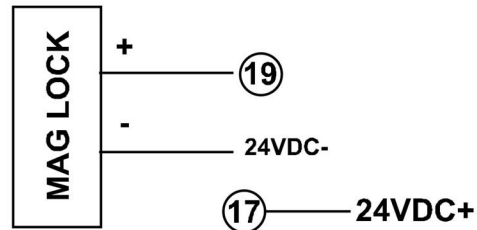

LOOP DETECTOR (SHADOW/HOLD OPEN)

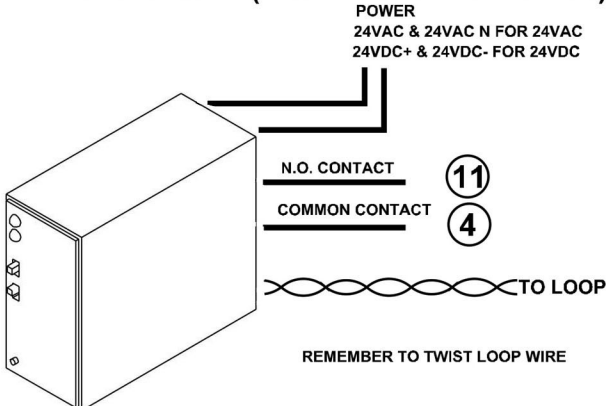

HEATER ASSEMBLIES (AC MODELS ONLY)

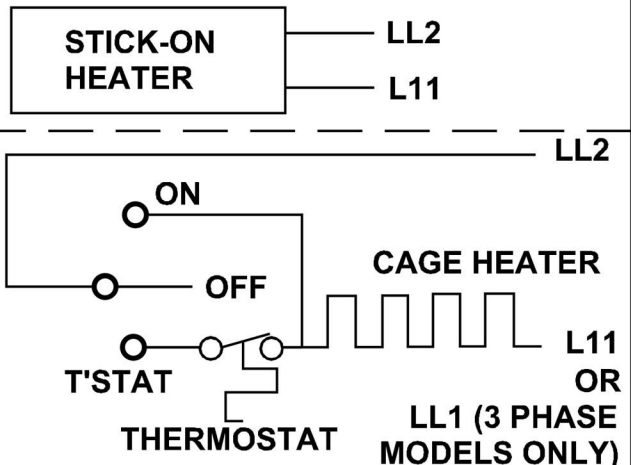

HSLG OPERATOR INSTALLATION GUIDE

LOOP LAYOUT ILLUSTRATION

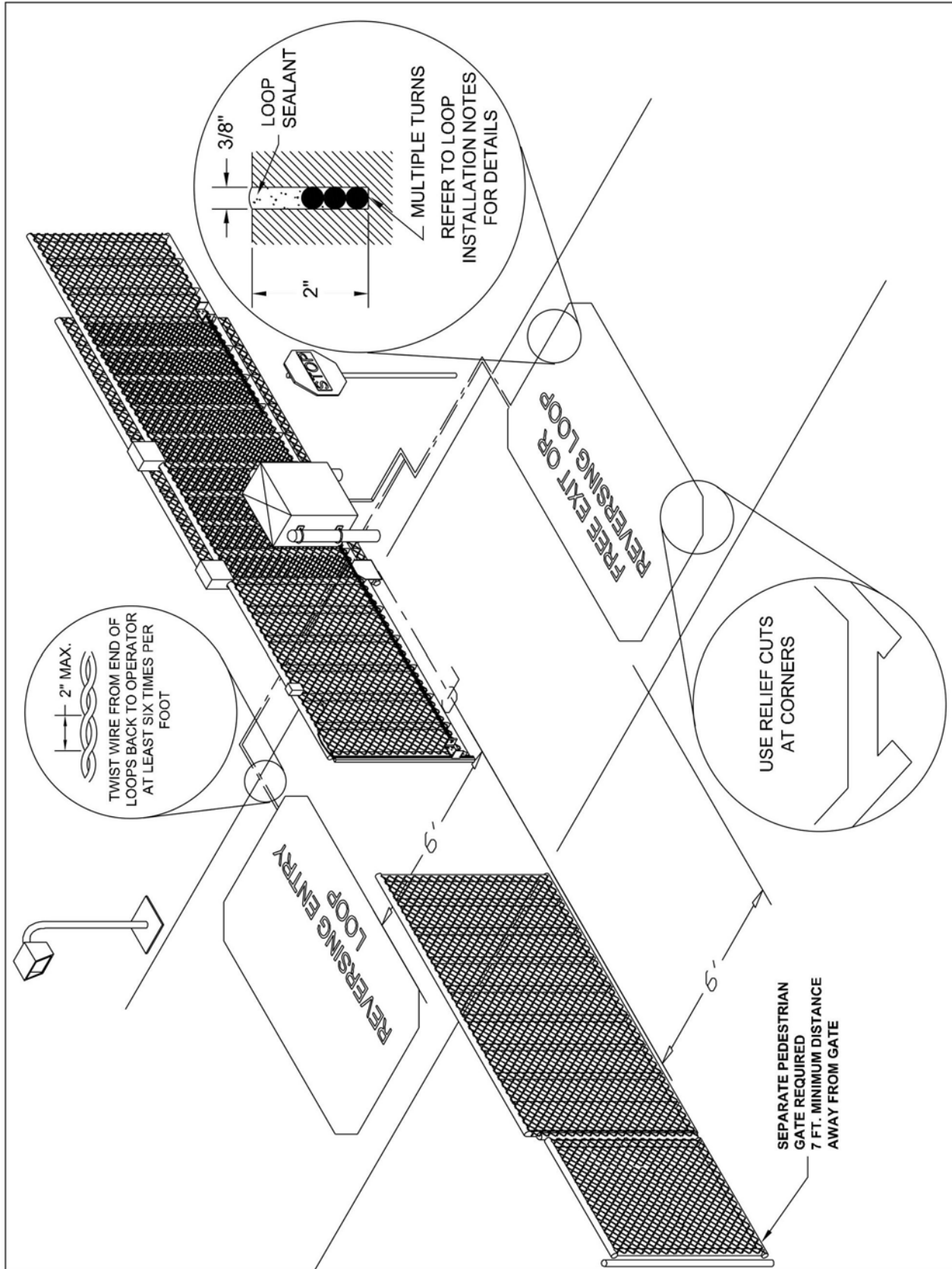

Refer to Connection Descriptions on page 10 and Loop Accessory Connections on page 17 for details.

HSLG OPERATOR INSTALLATION GUIDE

EDGE LAYOUT ILLUSTRATION #1

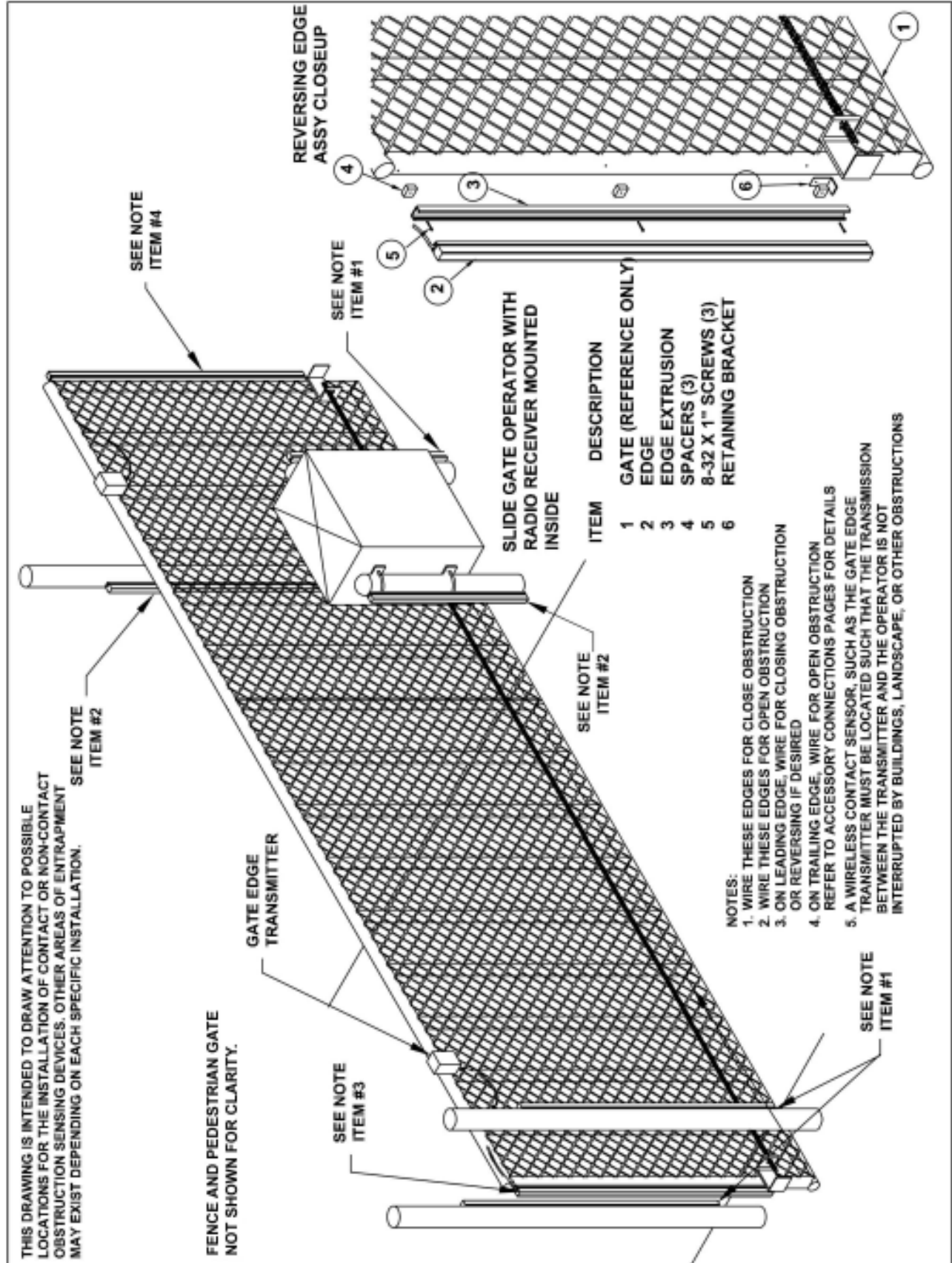

Refer to Connection Descriptions on page 10 and Contact Edge Connections on page 16 for details.

HSLG OPERATOR INSTALLATION GUIDE

EDGE LAYOUT ILLUSTRATION #2

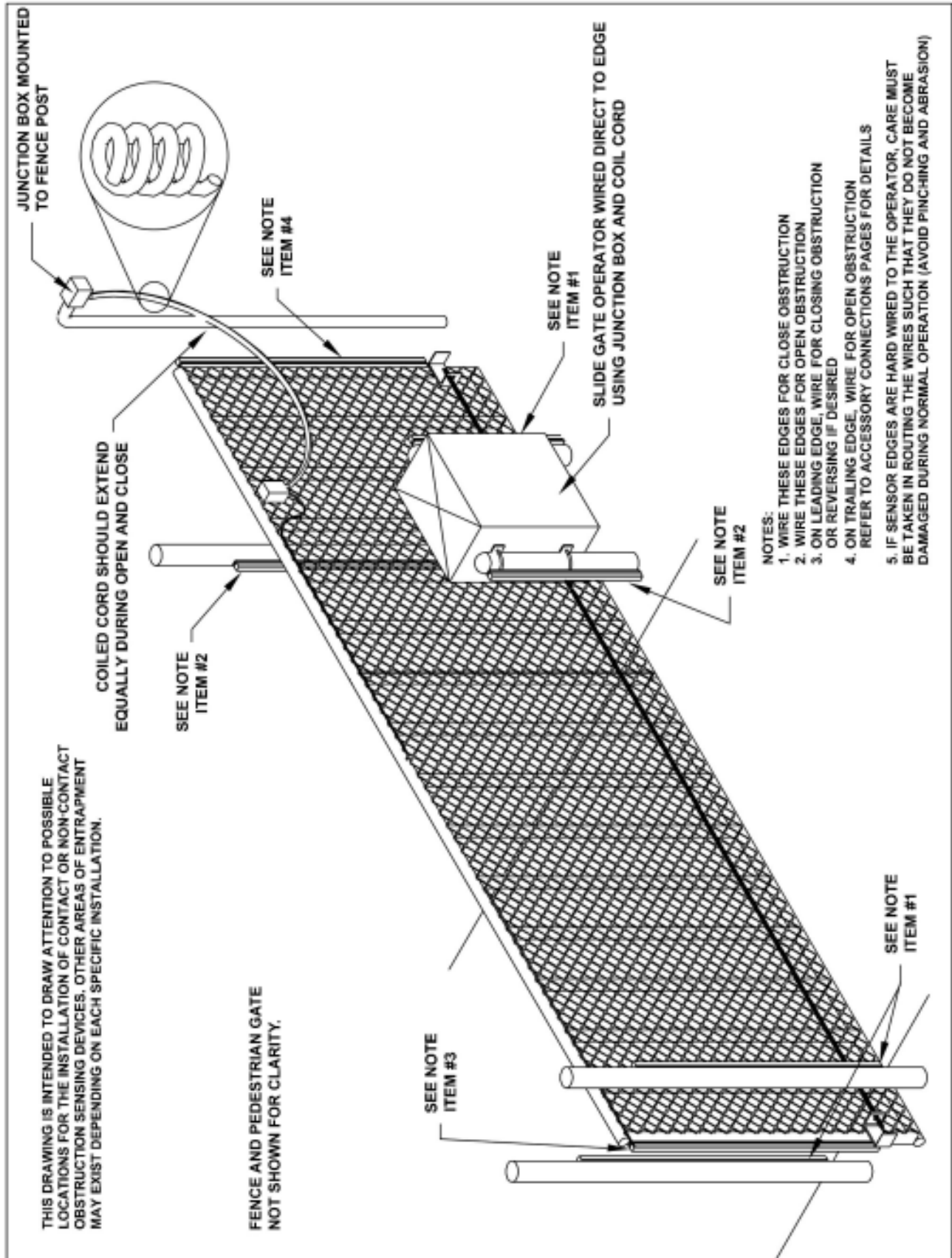

Refer to Connection Descriptions on page 10 and Contact Edge Connections on page 16 for details.

HSLG OPERATOR INSTALLATION GUIDE

PHOTO EYE ILLUSTRATION

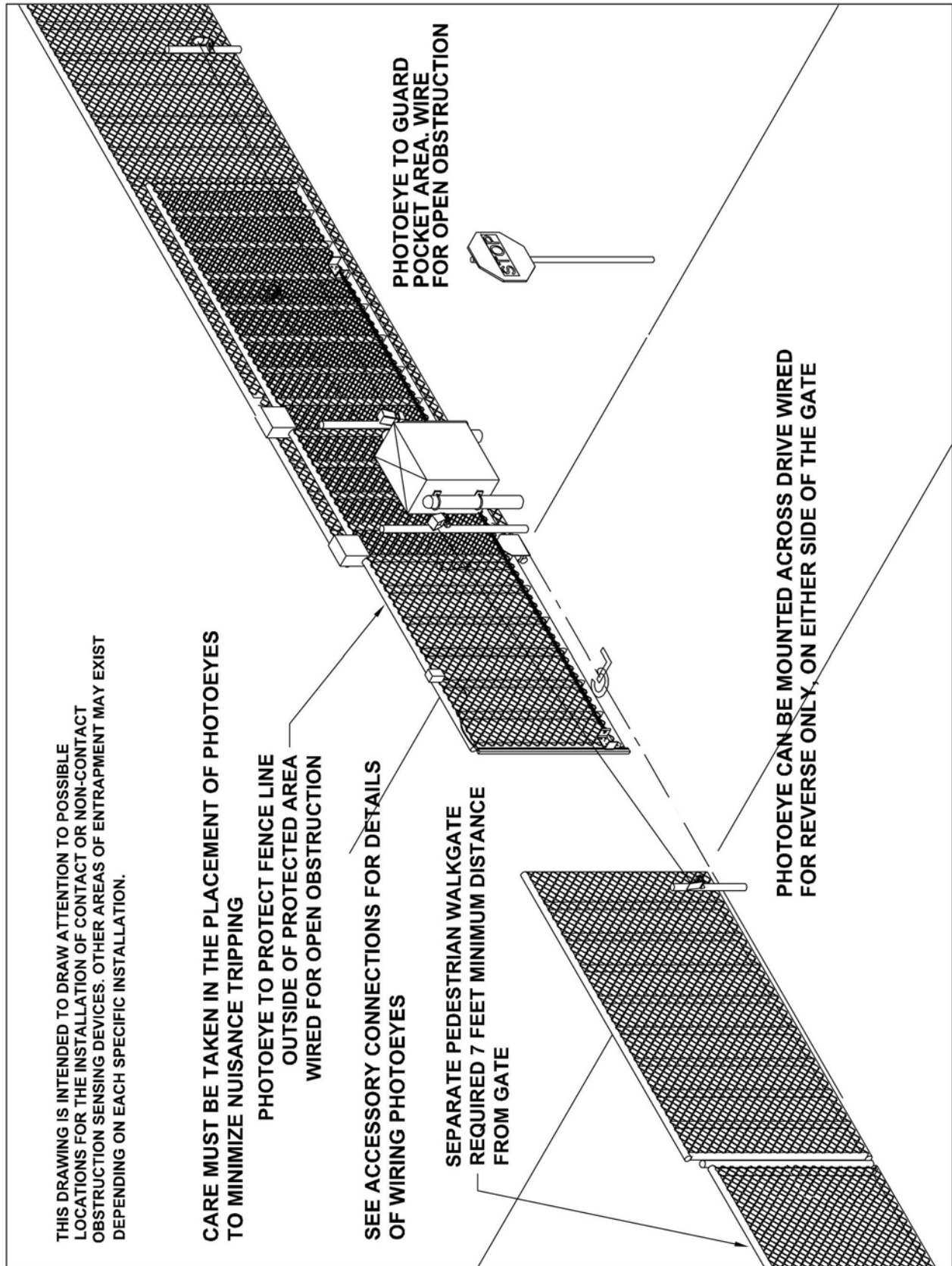

Refer to Connection Descriptions on page 10 and Photo Eye Connections on page 16 for details.

HSLG OPERATOR INSTALLATION GUIDE

PICKET GATE ILLUSTRATION

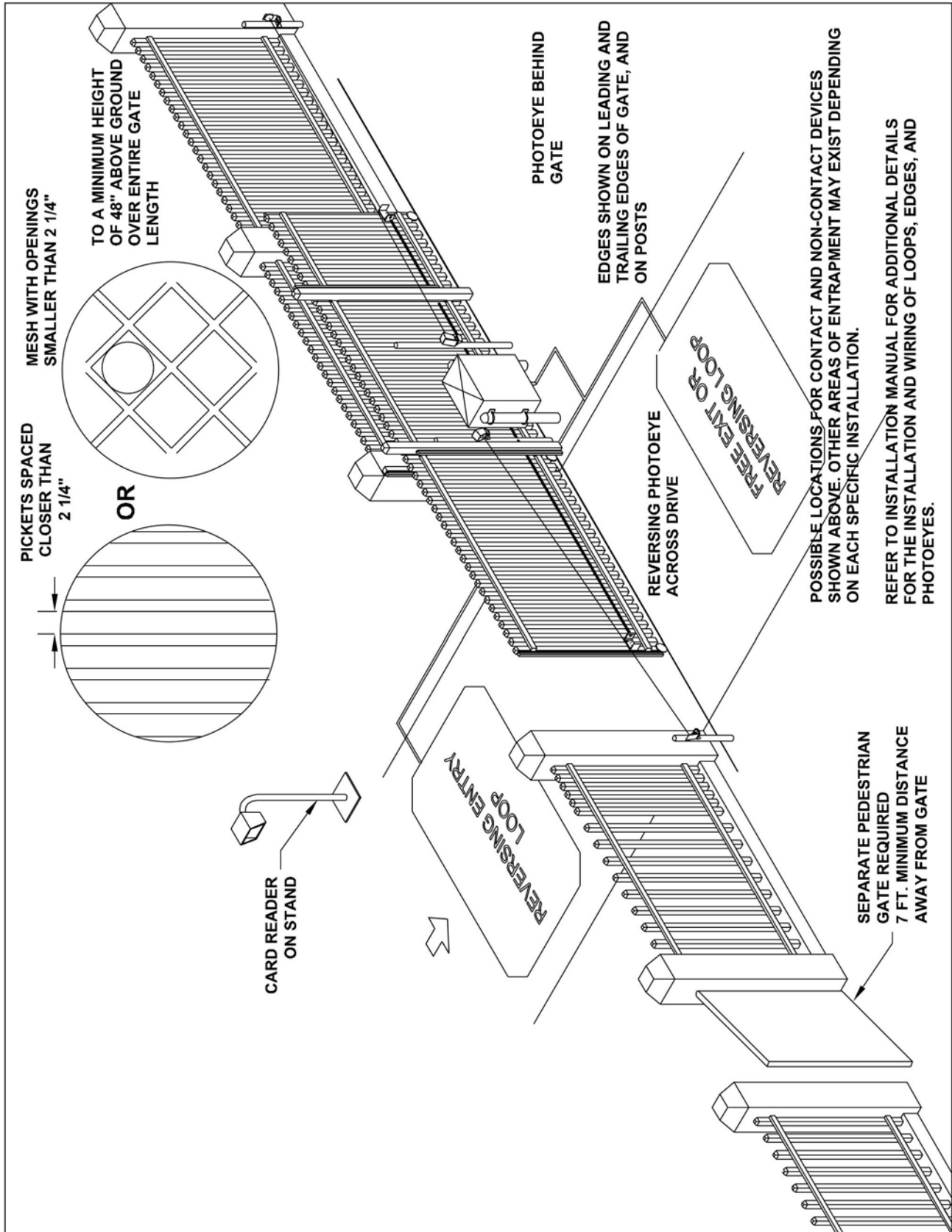

Refer to Connection Descriptions on page 10 and Accessory Connections on pages 14-17 for additional details.

HSLG OPERATOR INSTALLATION GUIDE

TRACK GATE ILLUSTRATION

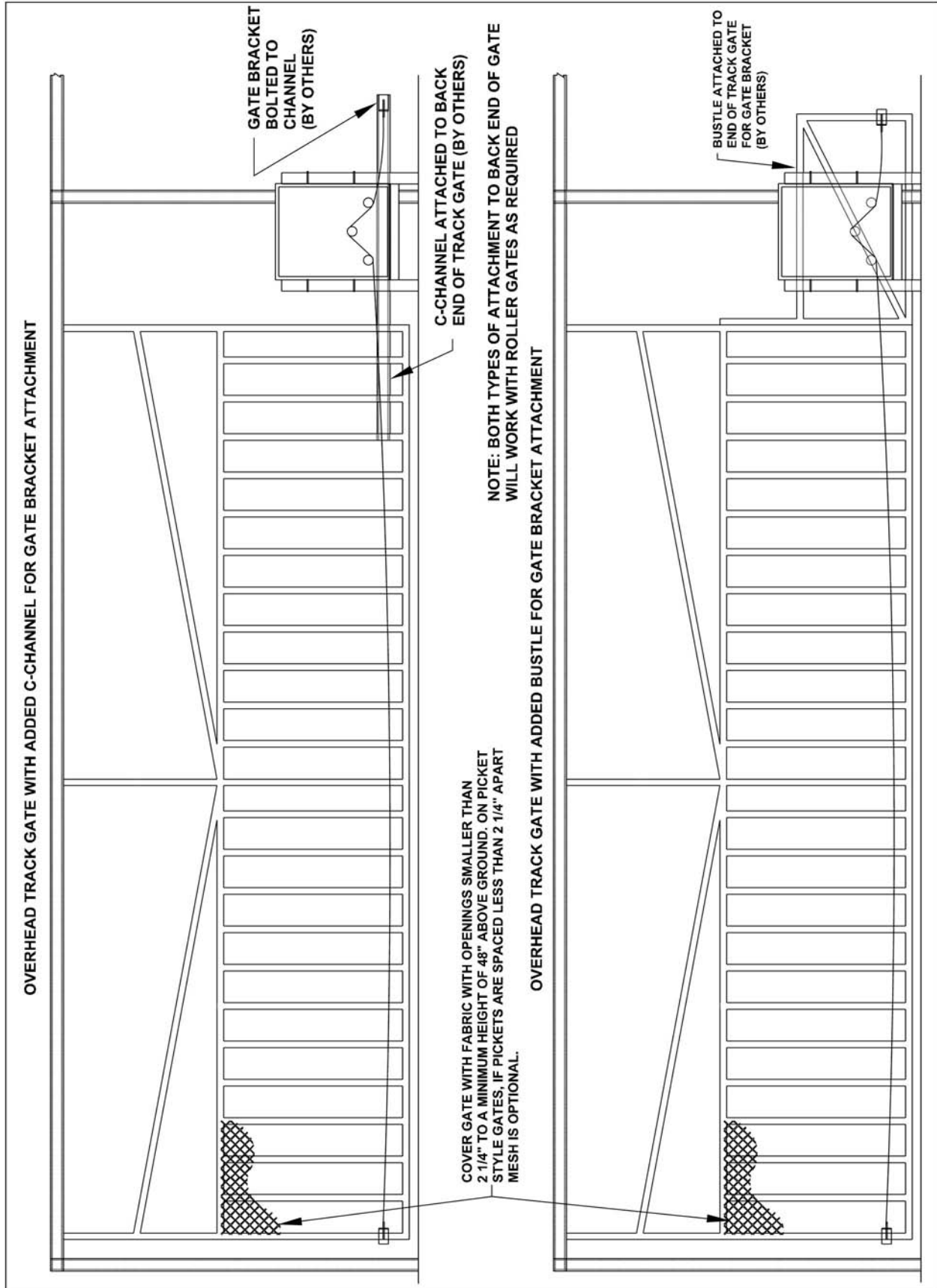

HSLG OPERATOR INSTALLATION GUIDE

TROUBLESHOOTING

Operator fails to start:

- A. If the operator has been running a large number of cycles, the motor may have gotten hot and tripped the overload. Allow the motor to cool down and the overload will reset automatically.
- B. Make sure you have power at the master distribution panel and that the power has not been turned off.
- C. The secondary fuse on the control board may have blown. Replace the fuse (refer to control box parts list on pages **26** [single phase] or **27** [three phase] for part number information).

Motor operates, but gate does not move:

- A. In operators with torque limiters and friction pad clutches, check for signs of slipping. You can mark the sprocket and clutch with a yellow or white grease pen and watch for the lines to move apart if slipping is taking place. Adjust the torque limiter tighter if this is the problem.
- B. Check for broken chain or worn belts.
- C. Check all setscrews on pulleys and sprockets and tighten them if necessary, and check for keys which may have fallen loose from keyways.

Motor sounds like it is working harder than normal:

- A. Make sure the gate is moving freely and without binding throughout its entire travel.
- B. Check the drive chain for obstructions (if the operator has one).
- C. If the operator has an internal brake mechanism, make sure it is releasing.

Limit switch getting out of time:

- A. Check for proper tension on all limit chains to be sure there is no jumping taking place. Mark one tooth and its corresponding link and run the gate. If the marks have moved, the chain is skipping.
- B. Check the setscrews in limit cams and limit sprockets for tightness. In rotary limit boxes, check the rotary limit nut for sloppiness or stripped threads. Replace if necessary.
- C. Check the chain tension along the output sprocket and idlers. Mark the chain and one tooth of the sprocket as described above and run the gate. Check for jumping.

Gate stopping part way open or closed (but no visible obstruction):

- A. The control board may have received a false obstruction input triggered by current sensing set too low. Make sure the gate moves freely through its entire travel before adjusting the current sensing.
- B. The maximum run timer may have counted down and expired. This can be caused by having the timer set too low, if a chain or belt is broken, or if a sprocket or pulley is slipping. When the timer expires, the gate stops and an alarm will sound.
- C. An obstruction signal from an accessory wired to the obstruction input may have triggered falsely. Check the control board for lit L.E.D. indicators for any of the following inputs: safety, shadow, open obstruction, close obstruction, stop, etc. If any are lit when the operator should be running, remove all devices hooked to that function and hook them up one at a time and try to run the operator until the problem device is found. Refer to page **12** for details on the control board indicators.

Gate staying open with automatic system:

- A. If there are vehicle detectors in your machine which are set up for reverse, one of your loops or loop detectors may be sending a false signal. Disconnect the wire harness and try running the operator.
- B. An opening or reversing device may be stuck or malfunctioning. Try disconnecting these devices and hook them back up one at a time and try running the operator until the malfunctioning device is found.
- C. Make sure the close limit switch isn't activated. If it is, the operator will think the gate is already closed.

HOW TO ORDER REPLACEMENT PARTS

Use the part numbers listed on the following pages. Contact your **local OSCO dealer** or **distributor** to order parts.

1. Supply the model number and serial number of your operator.
2. Specify the quantity of pieces needed and order by part number and name of part.
3. State whether to ship by freight, truck, parcel post, UPS or air express.
4. State whether transportation charges are to be prepaid or collect.
5. Specify name and address of person or company to whom parts are to be shipped.
6. Specify name and address of person or company to whom invoice is to be sent.

HSLG OPERATOR INSTALLATION GUIDE

MODEL HSLG MECHANICAL PARTS EXPLODED VIEW

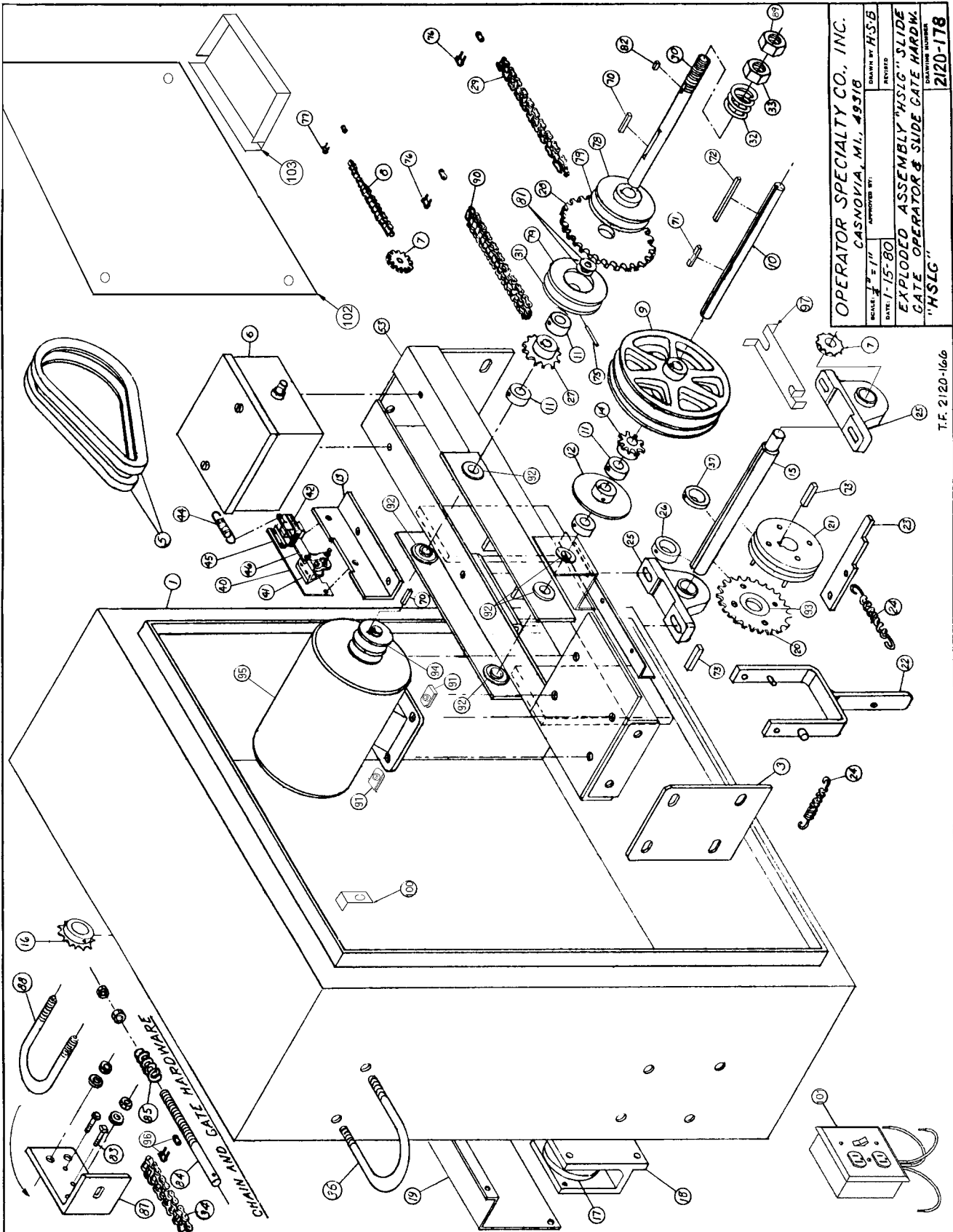

HSLG OPERATOR INSTALLATION GUIDE

MODEL HSLG MECHANICAL PARTS LIST

REF NO.	PART NO.	DESCRIPTION	REF NO.	PART NO.	DESCRIPTION
	2110-240	Intermediate Shaft Assembly			Motors
10	2100-765	Pulley Shaft	95	2500-2307	1/2 HP, 115V, 1 Phase
14	2200-213	Sprocket, 41 B 9, 5/8" Bore		2500-2308	1/2 HP, 208/230V, 1 Phase
9	2200-309	Double Pulley, 7"		2500-2309	3/4 HP, 115V, 1 Phase
11	2200-233	Set Collar Set, 5/8"		2500-2310	3/4 HP, 208/230V, 1 Phase
92	2200-215	Precision Bearing, 5/8"		2500-2311	1 HP, 115V, 1 Phase
72	2200-333	Key, 3/16" x 1 1/2"		2500-2312	1 HP, 208/230V, 1 Phase
71	2100-1750	Key, 3/16" x 1 1/4"		2500-2313	1/2 HP, 208/230/460V, 3 Phase
12	2100-547	Brake Disc		2500-2314	3/4 HP, 208/230/460V, 3 Phase
				2500-2315	1 HP, 208/230/460V, 3 Phase
	2110-274	Clutch Shaft Assembly			Capacitors
30	2100-1008	Clutch Shaft		2500-2336	Capacitor for 2500-2307 Motor
28	2200-294	Sprocket, 41 A 36, 1" Bore		2500-2337	Capacitor for 2500-2308 Motor
31	2100-669	Clutch Hub (Pinned)		2500-1926	Capacitor #1 for 2500-2309 Motor
78	2100-1007	Clutch Hub (Keyed)		2500-1930	Capacitor #2 for 2500-2309 Motor
79	2100-564	Clutch Facing		2500-1931	Capacitor for 2500-2310 Motor
32	2200-306	Clutch Spring		2500-2338	Capacitor for 2500-2311 Motor
33	2400-061	Hex Nut, 5/8"-18		2500-1932	Capacitor for 2500-2312 Motor
89	2400-062	Jam Nut, 5/8"-18			
81	2400-187	Thrust Washer, 1" x 1/8"			
	2400-088	Roll Pin, 3/16" x 1 3/8"	40	Magnetic Brakes (includes 41, 42, 44, 45 and 46)	
27	2200-292	Sprocket, 41 B12, 5/8" Bore		2510-398	115V
	2200-215	Precision Bearing, 5/8"		2510-399	230V
11	2200-233	Set Collar, 5/8"	41	2510-400	460V
70	2400-238	Key, 3/16" x 1 1/4"	42	2220-983	Brake and Puck Assembly
82	2400-273	Key, 3/16" x 1/4"		2500-177	Brake Solenoid, 230 VAC
				2500-178	Brake Solenoid, 115 VAC
				2500-1351	Brake Solenoid, 460 VAC
	2110-236	Output Shaft Assembly	44	2200-243	Brake Spring (short)
15	2100-917	Output Shaft, 1"	46	2100-548	Brake Rod
20	2220-022	Sprocket, 41 A 24 with Bearing	45	2100-541	Brake Plate
93	2200-119	Bearing only for 41 A 24 Sprocket	13	2100-2091	Bracket for Brake
21	2110-131	Shifter Block with Pins			
25	2200-274	Pillow Block Bearing, 1"	1	2120-359-BT	Enclosure Assembly Complete with Door
97	2100-1737	Pillow Block Retaining Plate		2120-360-BT	Door Assembly only
37	2200-014	Set Collar, 1" x 3/8" LTB		2300-716	Stop/Reset Button Cover
26	2200-091	Set Collar, 1" x 5/8" LTB		2110-643	Lock Assembly with Keys
73	2400-201	Key, 1/4" x 1 1/2"		2200-540	Replacement Key
			53	2110-234	Rail Assembly
16	2200-267	Sprocket, 40 B 18, 1" Bore	3	2100-573	Spacer Plate
	2400-026	Spring Pin, 3/16" x 1" (Predrilled for Pillow Block)	94	2200-207	Double Pulley, 2"
			29	2400-149	#41 Chain, 30 Links
			22	2120-132	Shifter Lever
18	2110-700	Idler Assembly	23	2100-910	Locking Disconnect Lever
			24	2200-291	Disconnect Spring
6	2520-173R	Rotary Limit Box Assembly	19	2100-657-BT	Rain Cover
	2500-764	Limit Switch	75	2400-088	Roll Pin
	2100-057	Standard Limit Shaft	87	2100-2007	Gate Bracket
	2200-030	Limit Nut	88	2400-170	U-Bolt, 3"
	2100-261	Detent Plate	84	2100-258	Chain Tension Bolt, 1/2"
	2110-162	Limit Box Enclosure with Cover	85	2200-306	Clutch/Chain Tension Spring
	2100-756	Limit Box Cover only	86	2400-090	Hex Nut, 1/2"-13 (4)
	2200-029	Flange Bearing, 1/2" ID		2400-045	Flat Washer, 1/2"
	2200-193	E-Ring, 1/2"		2500-867	Alarm, 24VAC
	2400-203	Spring Washer, 1/2"	5	2200-234	V-Belt, 28"
7	2200-008	Limit Drive Sprocket, 48-B-10, 1/2" Bore		2100-553	Bearing Spacer
		<i>For Drives up to 30 feet wide:</i>	90	2200-150	#41 Chain, per foot (20 links required)
	2200-008	Limit Box Sprocket, 48-B-10, 1/2" Bore	76	2200-027	#41 Master Link
	2200-654	#48 Chain, per foot, 27 Links required		2100-656-BT	Side Plate, 1/2"
		<i>For Drives from 31 to 45 feet wide:</i>		2100-059-BT	Side Plate, 3/16"
	2200-041	Limit Box Sprocket, 48-B-15, 1/2" Bore	96	2200-006	#40 Master Link
	2200-654	#48 Chain, per foot, 29 Links required	8	2200-654	#48 Chain, per foot (27 links required)
		<i>For Drives over 45 feet wide:</i>	77	2200-010	#48 Master Link
	2200-276	Limit Box Sprocket, 48-B-20, 1/2" Bore	91	2400-422	5/16-18 U-Nut (4)
	2200-654	#48 Chain, per foot, 30 Links required	100	2510-248	Stop/Reset Button and Bracket Assembly
34	2200-202	#40 Chain, per foot		2100-1760	Stop/Reset Button Mounting Bracket
36	2400-038	U-Bolt, 4 5/8"		2500-1495	Stop/Reset Button
	2510-064	Three-Button Station with Lead Wires	101	2510-251-D	Power On/Off Disconnect Assembly with Receptacles (115V Models only)
102	2100-1756	Control Box Mounting Plate		2500-1956	115VAC Duplex Receptacles only
103	2100-1781	Accessory Shelf for Single Phase Models only		2500-1957	115VAC Switch only
				2510-252-D	Power On/Off Disconnect Assembly for 230VAC Models
				2500-2205	230VAC Switch only
			101	2510-294	Power On/Off Disconnect Assembly for 3 Phase Operators
				2500-034	Power Switch only

HSLG OPERATOR INSTALLATION GUIDE

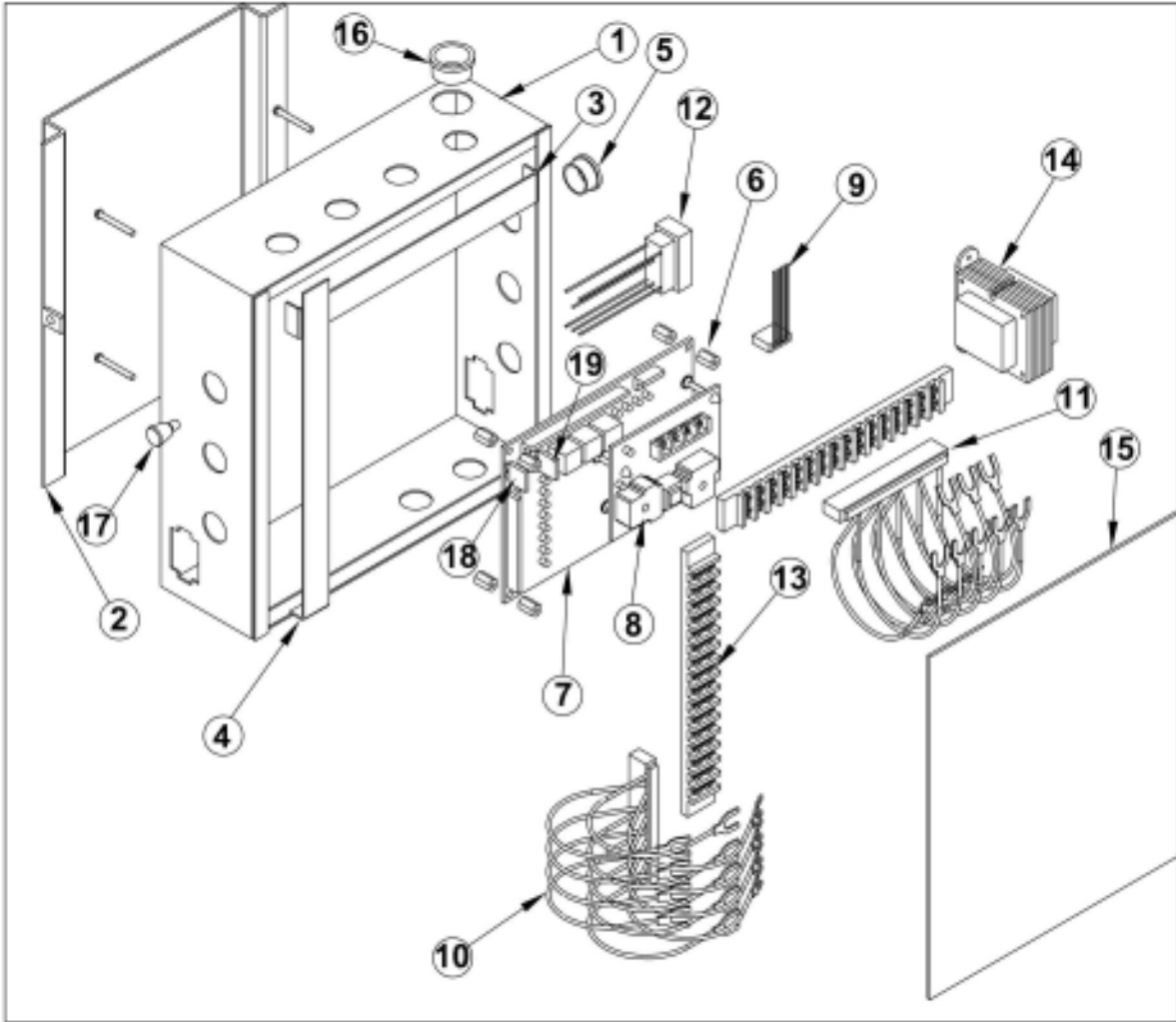

MODEL **HSLG** SINGLE PHASE CONTROL BOX PARTS LIST

REF NO.	PART NO.	DESCRIPTION	REF NO.	PART NO.	DESCRIPTION
1	2100-1778	Control Box Wrapper	15	2300-696	Clear Control Box Cover
2	2100-1757	Control Box Mounting Plate	16	2300-735	Heyco Bushing, 1.09 diameter
3	2100-1762	Terminal Strip Bracket, Output Side	17	2200-876	Plunger, Spring Loaded
4	2100-1761	Terminal Strip Bracket, Input Side		2500-867	Alarm, 24VAC (not shown)
5	2200-122	Heyco Bushing, .87 diameter	18	2500-1966	2 Amp Fuse for Control Board
6	2500-1948	Control Board Standoff	19	2500-1975	3 Amp Fuse for Control Board
7	2510-268	Control Board		2520-391-D	Complete Controller Assembly 115VAC (order limit harness and mounting brackets separately)
8	2500-1946	AC Motor Drive Board		2520-392-D	Complete Controller Assembly 230VAC (order limit harness and mounting brackets separately)
	2510-244	Control Board with AC Motor Board			
9	2510-253	Limit Switch Harness Assembly			
10	2510-249	Input Wire Harness Assembly			
11	2510-250	Output Wire Harness Assembly			
12	2510-261	Control Box Motor Harness Assembly			
13	2500-071	Terminal Strip, 16-141			
14	2500-212	Transformer, 115/24VAC 40VA			
	2500-791	Transformer, 230/24VAC 40VA			

HSLG OPERATOR INSTALLATION GUIDE

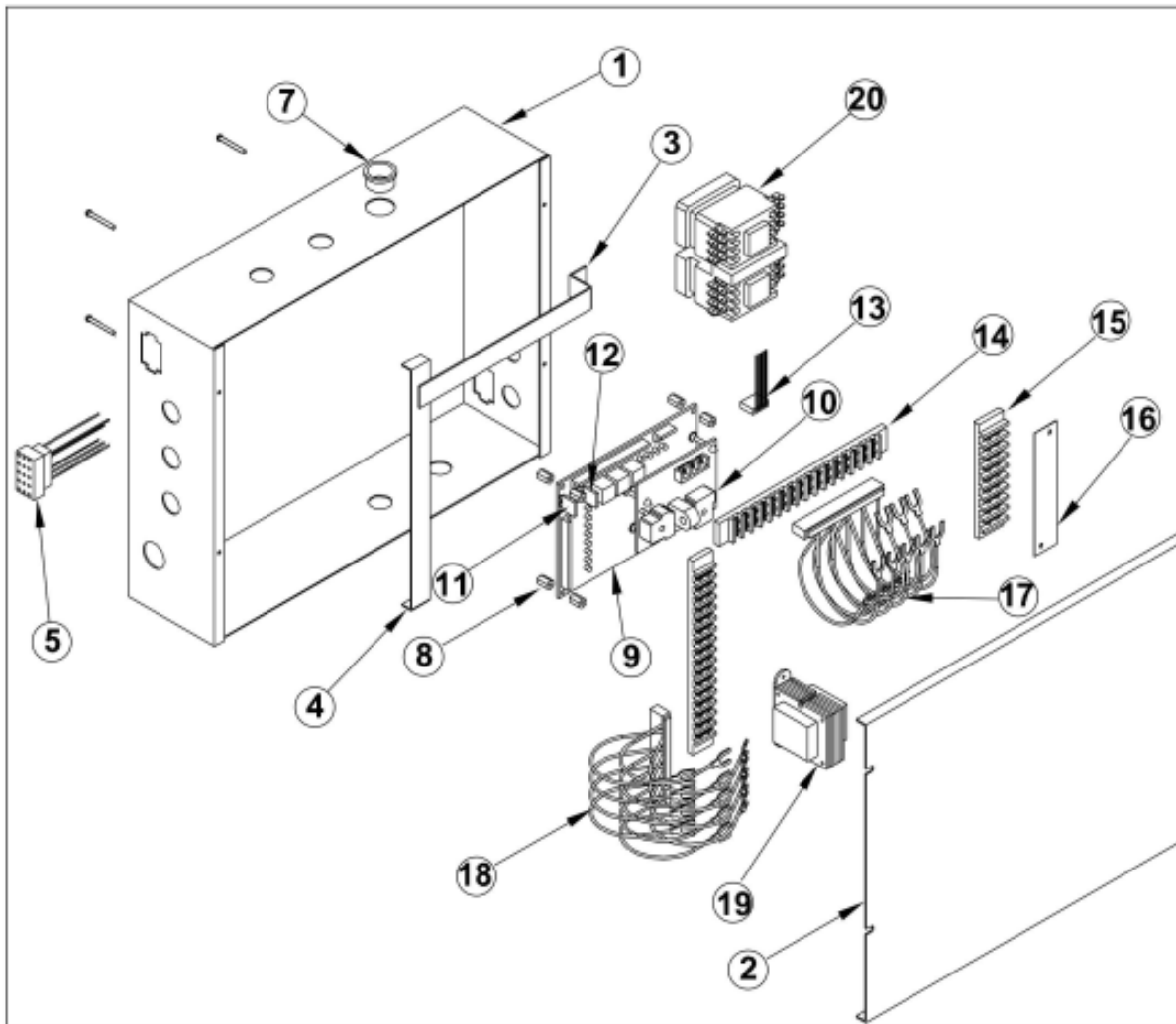

MODEL **HSLG** THREE PHASE CONTROL BOX PARTS LIST

REF NO.	PART NO.	DESCRIPTION	REF NO.	PART NO.	DESCRIPTION
1	2100-1865	Control Box Wrapper	14	2500-071	Terminal Strip, 16-141
2	2100-1866	Control Box Cover	15	2500-270	Terminal Strip, 9-142 OR
3	2100-1864	Terminal Strip Bracket		2500-185	Terminal Strip, 13-142
4	2100-1762	Terminal Strip Bracket	16	2300-488	Terminal Strip Barrier for 9-142 OR
5	2510-293	Control Box Motor Harness Assembly (Leeson motors)		2300-585	Terminal Strip Barrier for 13-142
	2510-355	Control Box Motor Harness Assembly (AO Smith motors)	17	2510-250	Output Wire Harness Assembly
7	2300-735	Heyco Bushing, 1.09 diameter	18	2510-249	Input Wire Harness Assembly
8	2500-1948	Control Board Standoff	19	2500-767	230/24VAC, 75VA, Transformer
9	2510-295	Control Board with 3 Phase Motor Board		2500-768	460/24VAC, 75VA, Transformer
	2510-268	Control Board only	20	2500-2084	24VAC Contactor
10	2500-1980	3 Phase Motor Board		2520-400	Controller, 208/230, 3 Phase
11	2500-1966	2 Amp Fuse for Control Board		2520-401	Controller, 460, 3 Phase
12	2500-1975	3 Amp Fuse for Control Board			(order limit harness and mounting hardware separately)
13	2510-253	Limit Switch Harness			

HSLG OPERATOR INSTALLATION GUIDE

PREVENTATIVE MAINTENANCE

IMPORTANT!

- Always disconnect power from operator before servicing.
- Keep clear of gate during operation.

GENERAL:

OSCO gate operators are designed for many years of trouble-free operation and, under recommended operating conditions, will require only minimal maintenance. To ensure that your unit is ready for operation at all times--and to preclude serious damage or failure--inspect the unit systematically. Proper adjustments and lubrication should be made as recommended.

LUBRICATION:

Bearings. For models which have pillow block style bearings with greaseable fittings, lubricate at least twice a year with a lithium complex based, petroleum oil NLGI 2 rated grease. Oilite and precision sealed bearings do not require additional lubrication.

Motor. Motors have sealed ball bearings and do not require further lubrication. If bearing noise develops after several years of operation, bearings should be replaced by a motor repair company, or the motor should be replaced if necessary.

Drive Chain and Sprocket (slide gate models only). The main drive chain and sprockets should be inspected for wear, cleaned, and wiped down with a lightly oiled rag every six months.

Swing Gate Arm (swing gate models only). Check all bolts for proper tension and tighten if necessary. Make sure the arm folds overextends itself slightly against the overtravel stop to reduce the chance that the gate can be backdriven open. Adjust the close limit slightly if additional travel is required. Lightly lubricate all pivot points with a light machine oil.

Barrier Gate Arm (barrier gate models only). Check all bolts for proper tension and tighten if necessary. If the arm has been warped or damaged, replace as necessary.

ADDITIONAL SIX MONTH PREVENTATIVE MAINTENANCE:

1. For operators which utilize torque limiting clutches, check for proper tightness. If there appears to be dust from wear on the pads, inspect the pads and replace if necessary. If the clutch cannot be adjusted tightly enough to move the gate without slipping, the pads must be replaced.
2. For operators with V-belts, inspect for wear and replace as necessary. Check for proper tension and adjust if required. Check all pulley setscrews for tightness and tighten if necessary.
3. For operators with internal chain drives, inspect chain and sprockets for wear and replace if necessary. Check for proper tension and alignment, and adjust if required. Check all hub sprocket setscrews and tighten if required.
4. Check limit switches and limit actuators (cams, limit nuts, etc.) for wear and replace as required. In rotary limit switch assemblies, wipe the limit shaft clean and apply a light coating of dry lubricant.
5. For operators with magnetic brakes, check for proper adjustment. Brake disc must run free when the brake is engaged. For brake assemblies other than C-face style, the brake should be adjusted so that the solenoid plunger throw is between 3/8" to 1/2". Too much throw will damage the solenoid. **If the solenoid emits a loud buzzing sound when the motor is run, the brake must be adjusted.**
6. In operators which have a disconnect handle, inspect disconnect handle for proper function and lubricate if necessary. Use a lithium based grease on all moving parts.
7. Inspect all nuts and bolts for proper tightness and tighten as necessary.
8. Check all reversing devices for proper function. Inspect all contact edges for wear and replace if required. Check photoeyes for proper alignment and function.
9. Check current sensing for proper adjustment when finished with inspection and maintenance.
10. Inspect the installation area. Are all the warning signs intact and visible? If they are missing or need replaced, contact OSCO. Be sure there are no control stations mounted within reach of the gate. Review safety literature with the customer and advise them to remove any such stations found.

For slide and swing gate operators, you must inspect the gate for proper operation. The gate should move easily without binding through its entire travel. If the gate does bind, adjust or fix as required. Failure to keep the gate in good working condition will have adverse effects on the operator.

HSLG OPERATOR INSTALLATION GUIDE

GATE OPERATOR INSTALLATION CHECKLIST

INSTALLER	CUSTOMER	
_____	_____	1. The gate has been checked to make sure it is level and moves freely in both directions.
_____	_____	2. Potential pinch areas have been guarded so as to be inaccessible OR have contact and/or non-contact obstruction sensing devices installed.
_____	_____	3. The installer has installed one or more contact or non-contact obstruction sensing devices, in compliance with UL325 requirements for this installation.
_____	_____	4. The slide gate has been screened or secured from the bottom of the gate to a minimum of 48 inches above ground to prevent a 2 1/4-inch sphere from passing through the openings anywhere in the gate and in that portion of the adjacent fence that the gate covers when the gate is in the open and closed positions. Picket gates which have spacings less than 2 1/4 inches apart to the minimum height requirement are also acceptable.
_____	_____	5. Roller covers have been installed on cantilever gates.
_____	_____	6. If pedestrian traffic is expected, a separate pedestrian gate has been installed, a minimum of seven feet from the gate. The customer has been informed that <u>all pedestrian traffic must use the pedestrian gate.</u>
_____	_____	7. Warning signs have been installed on each side of the gate in highly visible locations. The customer has been informed that these signs must remain at all times.
_____	_____	8. There are no controls installed on the gate operator, or within seven feet of the gate.
_____	_____	9. The installer has properly adjusted the obstruction sensing feature and has tested the gate to make sure that the gate stops and reverses a short distance with minimal resistance applied (40 lbs. on a swing gate at the end of the gate, 75 lbs. on a slide gate)
_____	_____	10. The installer has instructed the customer in the proper use of the gate operator and reviewed all of the operational functions, obstruction sensing devices, warning beeper and reset, etc.
_____	_____	11. The installer has instructed the customer in the proper use of the operator's manual disconnect feature. The manual disconnect must never be used while the gate is in motion. The power switch must be turned off before using the manual disconnect and disengaging the operator.
_____	_____	12. The installer has reviewed all safety instructions with the customer, and has left the safety instructions and owner's information sheets for their reference.
_____	_____	13. The installer has answered any questions the customer has regarding the operation of the gate operator and gate operator safety precautions.
_____	_____	14. The installer has explained to the customer that a regular maintenance schedule for both the gate and the gate operator is recommended.

By signing this installation checklist, I/we hereby certify that each item listed and checked above has been covered by the installer and is clearly understood by the customer.

Customer Signature

Date

Installer Signature

Date