

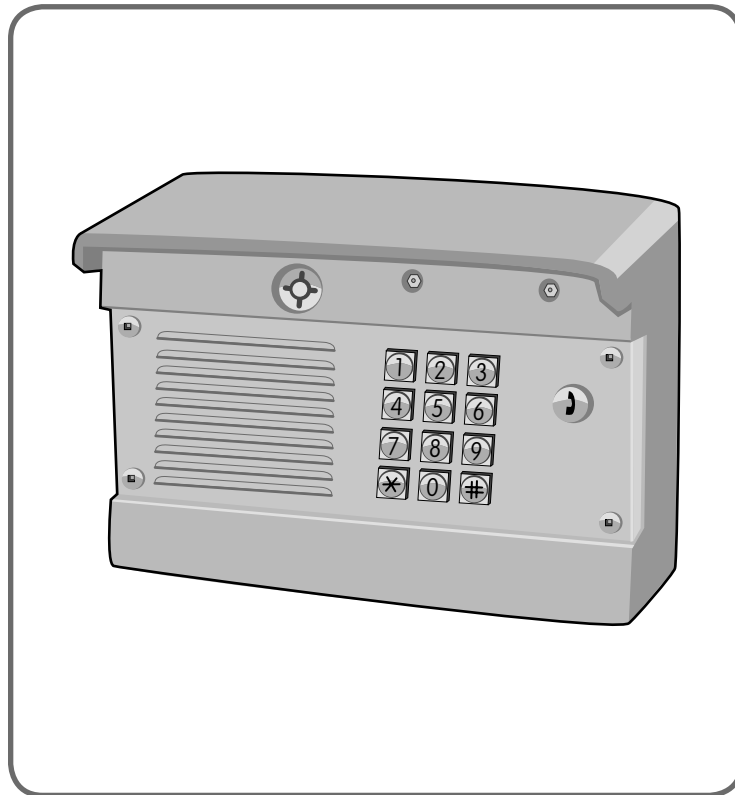

TAC1

Telephone Entry System



Installation and Programming Manual

The Chamberlain Group
845 Larch Ave.
Elmhurst, IL 60126-1196
www.liftmaster.com

TABLE OF CONTENTS

SPECIFICATIONS

Cable Requirements	3
Dimensions	3
Carton Inventory	3

INSTALLATION

Mount the Back Panel	4
Description of the Processor Board	4
Overview of Telco Wiring	5
Wiring the Unit With a Telco Line	6
Wiring the Unit Without a Telco Line	6
Wiring a Gate Operator	7
Wiring an Auto-Call Sensor	7
Wiring a Gate Operator and a Door Strike Lock	8
Wiring a Gate Operator and a Maglock	8
Wiring a Door Strike Lock	9
Wiring a Maglock	9
Earth Ground Rod	10
Power Wiring	10
Plug the Transformer into the Outlet	11
Mount the Unit	11
Set the Master Code	11

4-11

TESTING

Test the Gate/Door Relay	12
Test the Telephone Connections	12

PROGRAMMING

From the TAC1 Keypad	13
Code Setup and Code Operation	14
From the Telephone	15-16
Program a Pre-Installed Liftmaster Receiver	16
Quick Reference	17-18

13-19

TAC1 MASTER CODE

19

LIMITED WARRANTY

20

SPECIFICATIONS >> CABLE REQUIREMENTS, DIMENSIONS AND CARTON INVENTORY

CABLE REQUIREMENTS

Outdoor installations require shielded cable. Non-shielded cable can be used for indoor installations ONLY.

Processor Board	Wire Type	Recommendations
From the power transformer at 120 Vac outlet	2 - Conductor Cable	Shielded Only - See Power Wire Table Below
From the door strike, maglock or gate operator	2 - Conductor Cable	See device specifications for wire size
From the strike power supply (if needed)	2 - Conductor Cable	See device specifications for wire size
From the Earth ground to processor board	12 AWG copper wire, PVC insulated or 12 AWG copper wire, uninsulated	Belden #9912 Belden #8011
Residence and Telco phone lines	24 AWG twisted pair telephone wire	Shielded - Belden #9502
From the Processor Board	24 AWG twisted pair telephone wire	Shielded - Belden #9502
Between Processor Boards on multiple entrance installation	24 AWG twisted pair telephone wire	Shielded - Belden #9502

POWER WIRE TABLE

Distance	AC Power Wire Size
Under 30 feet	18 AWG
30 - 75 feet	18 AWG
75 - 150 feet	18 AWG
150 - 250 feet	16 AWG
250 - 500 feet	12 AWG

NOTE: Chamberlain is not responsible for conflicts between the information listed in the above table and the requirements of local building codes. The information is for suggested use only. Check local building codes before installation.

DIMENSIONS

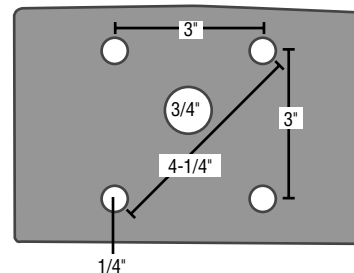
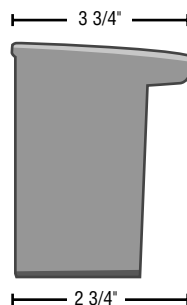
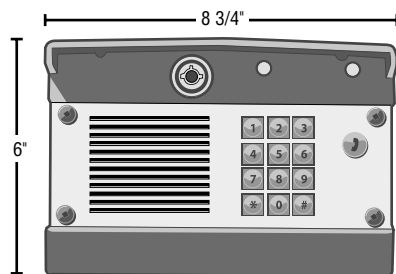

Power Supply: 12 Vac 20 VA

CARTON INVENTORY

- Unit (unlocked) (1)
- Key (1)
- 12 Volt AC 20VA Plug-In UL Listed Power Transformer (1)
- Manual (1)

INSTALLATION >> MOUNT THE BACK PANEL AND OVERVIEW OF THE PROCESSOR BOARD

MOUNT THE BACK PANEL

Choose the mounting location for the unit. Remove the back panel and attach the unit to a solid surface or post (hardware not provided).

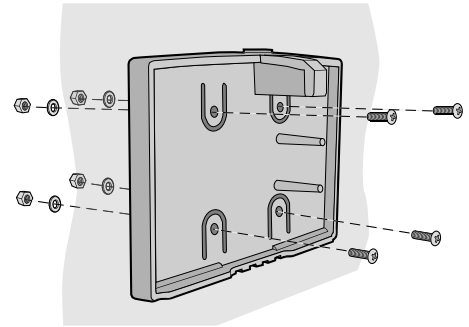

DESCRIPTION OF THE PROCESSOR BOARD

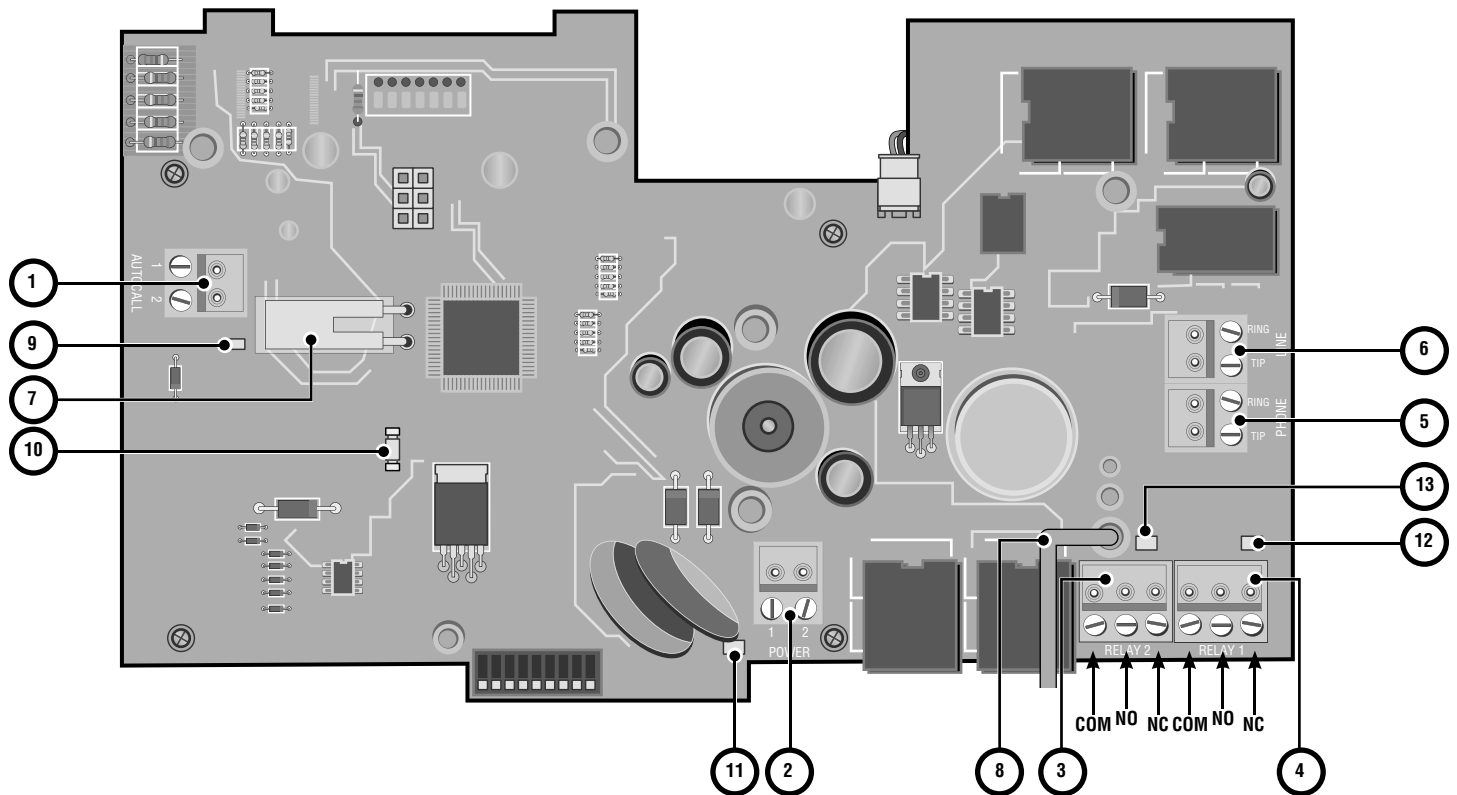

- ① **Autocall Input:** Connector for accessory device to trigger home dialing.
- ② **Power Connector:** 12 volt AC power input.
- ③ **Relay 2 Output:** Form "C" secondary control relay.
- ④ **Relay 1 Output:** Form "C" primary control relay.
- ⑤ **Phone Output:** Telephone return connection to home or office phones.
- ⑥ **Line Input:** Telephone input connection from "Telco" service provider.
- ⑦ **Tamper Switch**
- ⑧ **Ground Wire:** Wire must be connected to positive earth ground. See Earth Ground Rod.
- ⑨ **Status LED**
- ⑩ **Voice Data Send Status LED**
- ⑪ **Power Status LED**
- ⑫ **Relay 1 (Primary) Output Status LED**
- ⑬ **Relay 2 (Secondary) Output Status LED**

INSTALLATION >>OVERVIEW OF TELCO WIRING

Many phone companies have updated their color standards due to the use of Cat 5 cable for most phone line installs, and keep residential and business installs in line with each other. In the new standard, there is no green, red, black or yellow wires, they have been replaced by white/blue, blue/white, white/orange, and orange/white. If the wire is primarily orange with white stripes then that color is orange/white. Refer to the table below. The NID labels will most likely have the old coloring scheme on them, and most telephone wiring components you can purchase will still reflect the original colors.

Notes about wire connectors (terminal blocks):

- Wire connectors can be removed to simplify wiring.
- Do NOT overload wire connectors. Use ONLY one wire per hole.

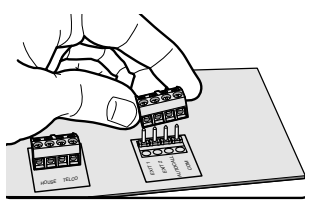

Function	Old Color Standard	New Color Standard
Tip 1	Green	White/Blue
Ring 1	Red	Blue/White
Tip 2	Black	White/Orange
Ring 2	Yellow	Orange/White

Typical Telco Overview

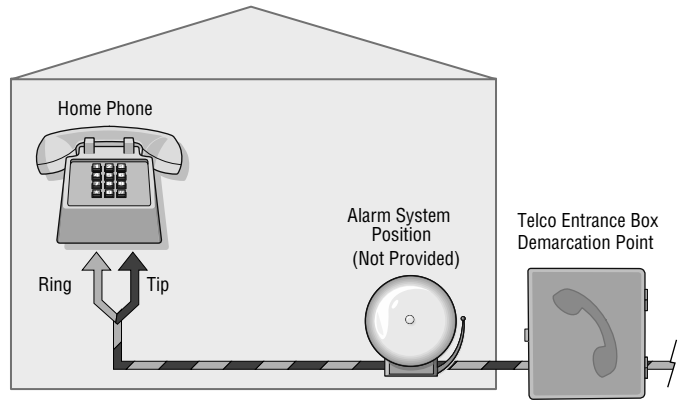

NOTES:

- The voltmeter measurement between the Tip and Ring should be between 48 and 53 V dc.
- Never run data wires and high voltage wires in the same conduit. The high voltage wires may interfere with the data wires and cause the system to malfunction.
- Reversed polarity will not damage the unit, however, some telephones will not function properly.

Typical Telco Overview With The Unit

NOTE: If the unit will be connected with an alarm system, you must connect the telephone line to the alarm system first in the series from the Telco box. If the units are not connected in this order, they will not operate properly.

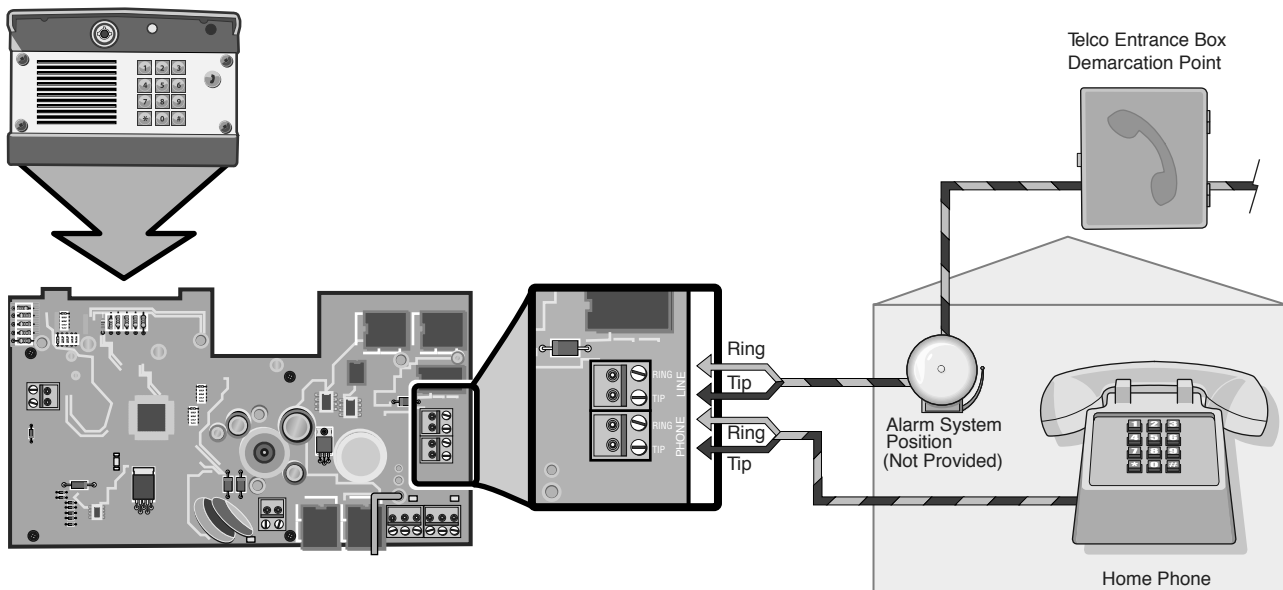

INSTALLATION >> WIRING THE UNIT WITH A TELCO LINE AND WIRING THE UNIT WITHOUT A TELCO LINE

Never run data wires and high voltage wires in the same conduit. The high voltage wires may interfere with the data wires and cause the system to malfunction.

WIRING THE UNIT WITH A TELCO LINE

Ringer Equivalence Number (REN) = 5

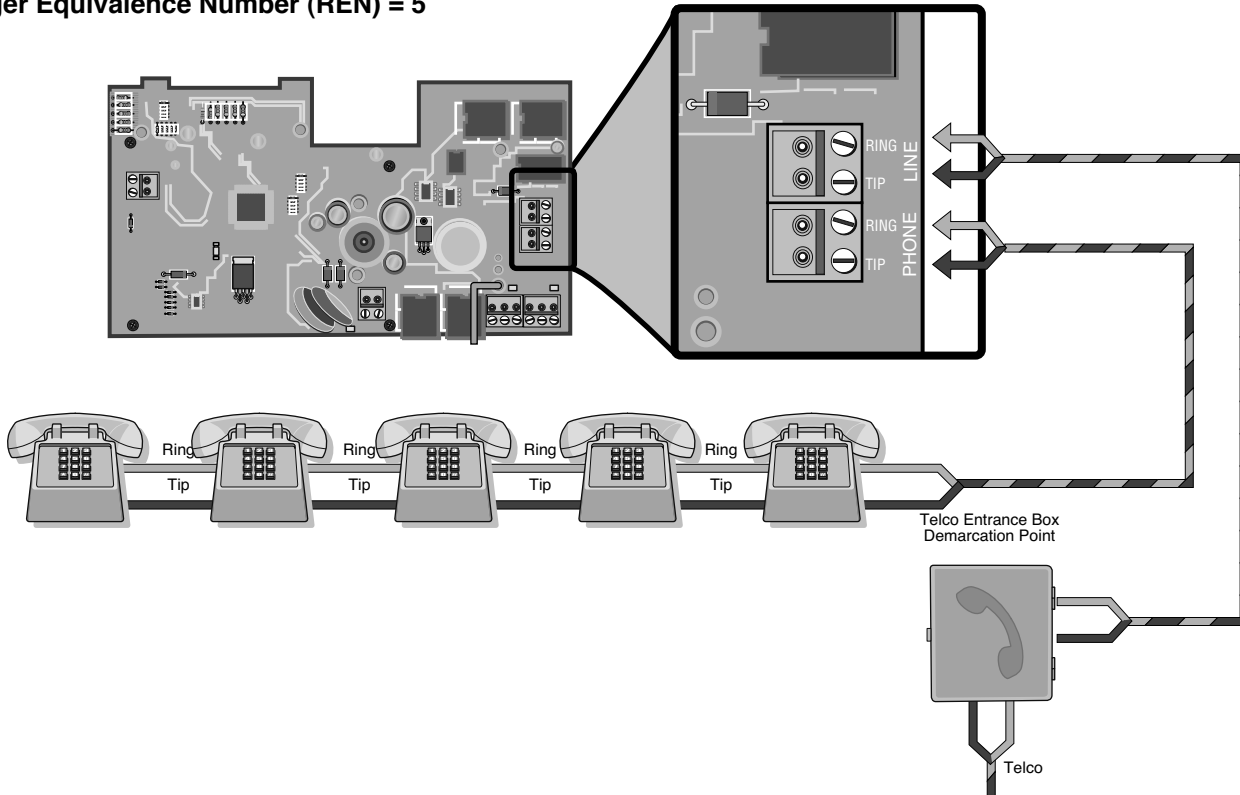

WIRING THE UNIT WITHOUT A TELCO LINE

The unit can be a stand alone system that allows communication between the unit and the resident's phones.

Ringer Equivalence Number (REN) = 3

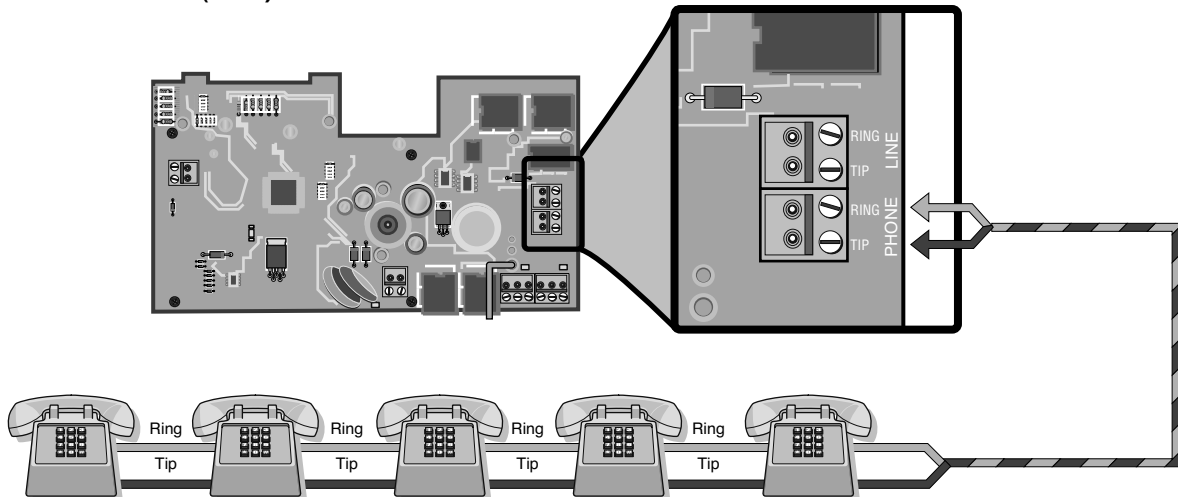

INSTALLATION >> WIRING A GATE OPERATOR (NORMALLY OPEN) AND WIRING AN AUTO-CALL SENSOR

WIRING A GATE OPERATOR (NORMALLY OPEN)

The gate operator can be connected to Relay 1 or Relay 2. See the *Programming* section for information about configuring Relays 1 and 2.

Notes about wire connectors (terminal blocks):

- Wire connectors can be removed to simplify wiring.
- Do NOT overload wire connectors. Use ONLY one wire per hole.

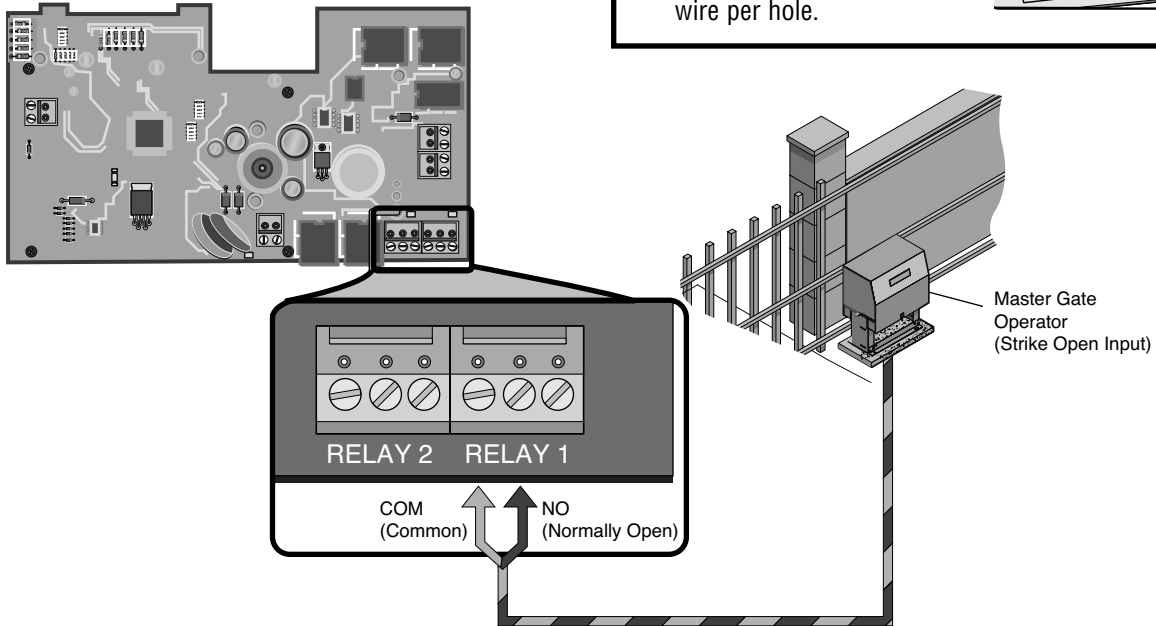
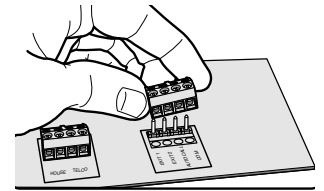

WIRING AN AUTO-CALL SENSOR

The Auto-Call feature will enable the unit to contact the resident when a driveway sensor (or any device that provides a contact closure) is activated.

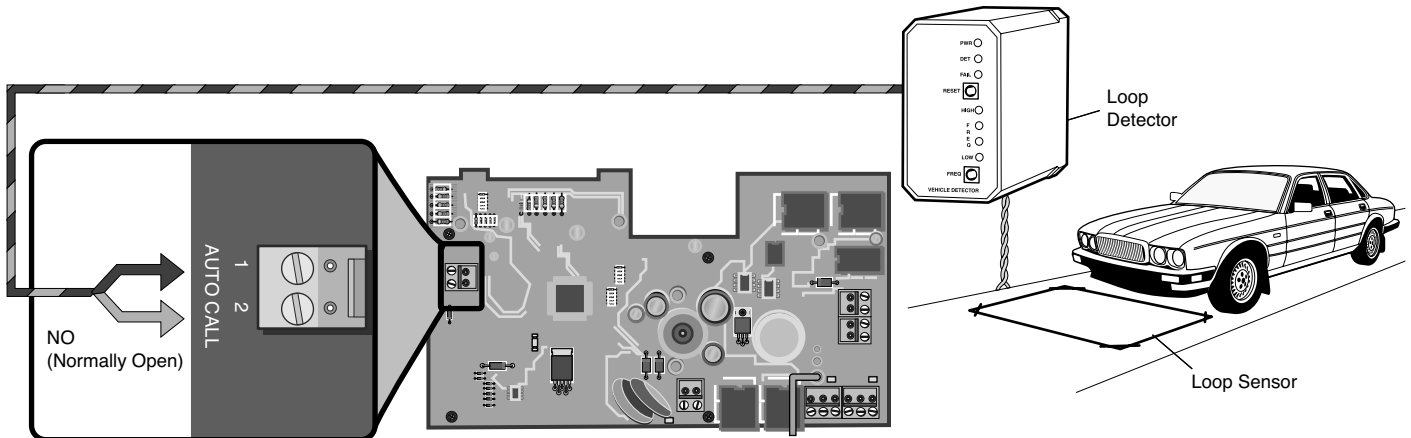

INSTALLATION >> WIRING A GATE OPERATOR (NORMALLY OPEN) A DOOR STRIKE LOCK (NORMALLY OPEN) AND WIRING A GATE OPERATOR (NORMALLY OPEN) & A MAGLOCK (NORMALLY CLOSED)

WIRING A GATE OPERATOR (NORMALLY OPEN) & A DOOR STRIKE LOCK (NORMALLY OPEN)

The door strike can be connected to Relay 1 or Relay 2. See the *Programming* section for information about configuring Relays 1 and 2.

Notes about wire connectors (terminal blocks):

- Wire connectors can be removed to simplify wiring.
- Do NOT overload wire connectors. Use ONLY one wire per hole.

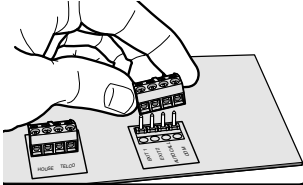
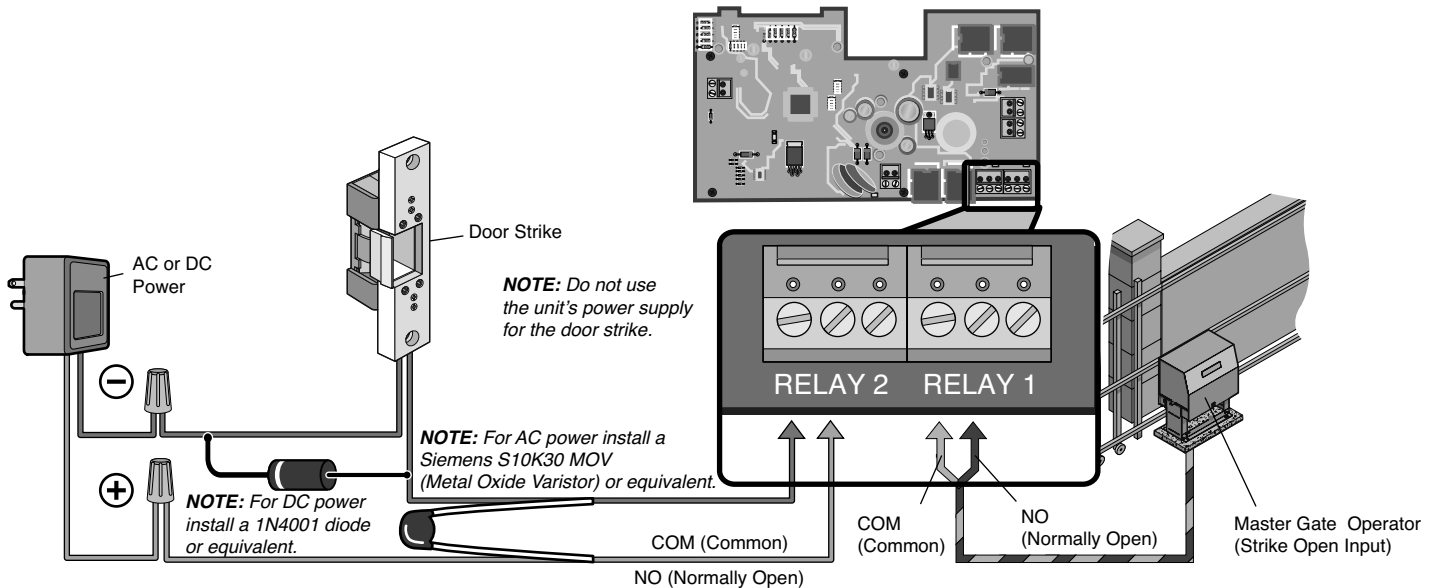
WIRING A GATE OPERATOR (NORMALLY OPEN) & A MAGLOCK (NORMALLY CLOSED)

The maglock can be connected to Relay 1 or Relay 2. See the *Programming* section for information about configuring Relays 1 and 2.

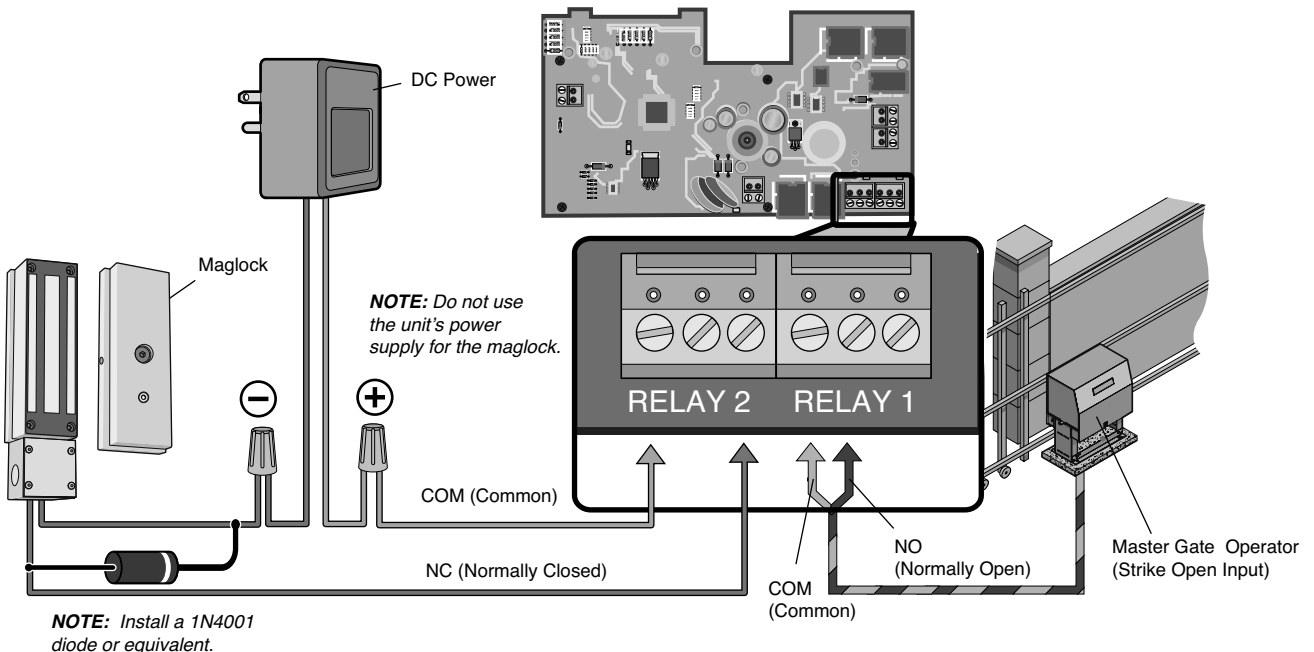

INSTALLATION >> WIRING A DOOR STRIKE LOCK (NORMALLY OPEN) AND WIRING A MAGLOCK (NORMALLY CLOSED)

WIRING A DOOR STRIKE LOCK (NORMALLY OPEN)

The door strike can be connected to Relay 1 or Relay 2. See the *Programming* section for information about configuring Relays 1 and 2.

Notes about wire connectors (terminal blocks):

- Wire connectors can be removed to simplify wiring.
- Do NOT overload wire connectors. Use ONLY one wire per hole.

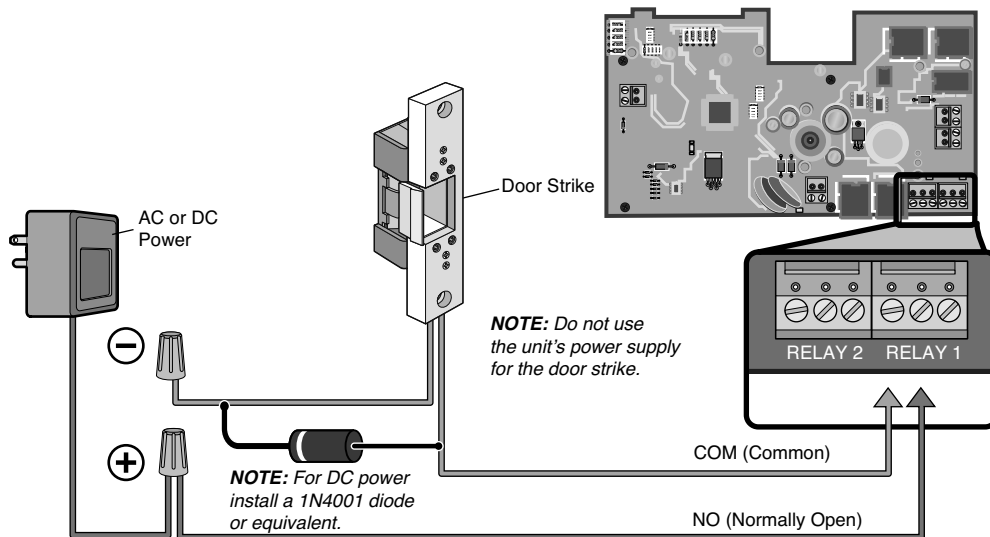
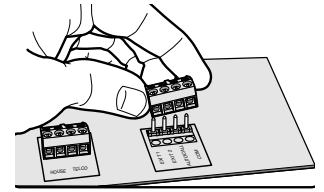

WIRING A MAGLOCK (NORMALLY CLOSED)

The maglock can be connected to Relay 1 or Relay 2. See the *Programming* section for information about configuring Relays 1 and 2.

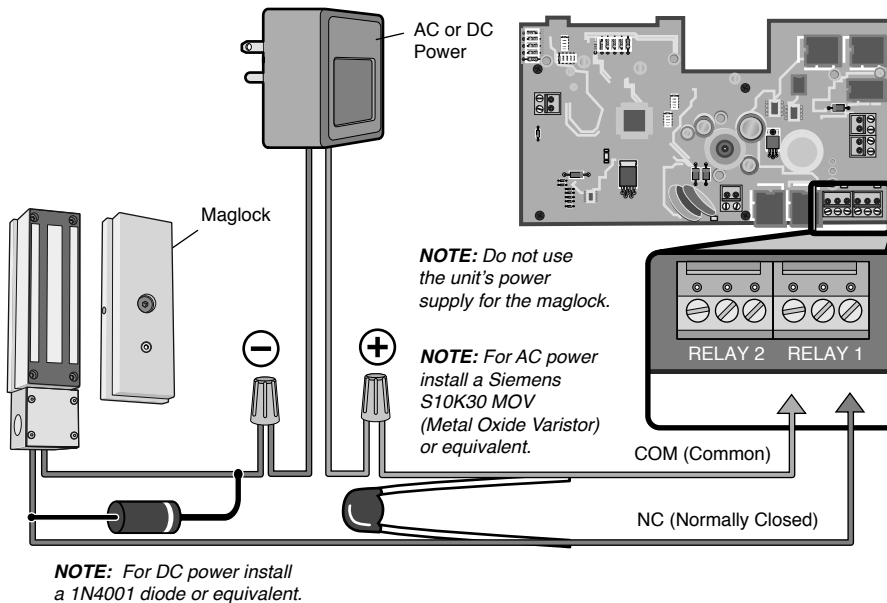

INSTALLATION >> EARTH GROUND ROD AND POWER WIRING

EARTH GROUND ROD

Ensure that the unit is grounded properly. The unit contains a number of static sensitive components that can be damaged by static discharge.

NOTES:

- Use a minimum of 12 gauge wire in most cases. The type and length of the earth ground rods vary by region. Contact the building inspector's office in the municipality where you plan to install the unit for correct grounding materials and installation procedures.
- Do not ground the unit to a pedestal post (gooseneck) if one is used.

1. Install the earth ground rod within 12 feet of the unit.
2. Attach a 12 AWG wire to the unit ground wire with a wing nut.

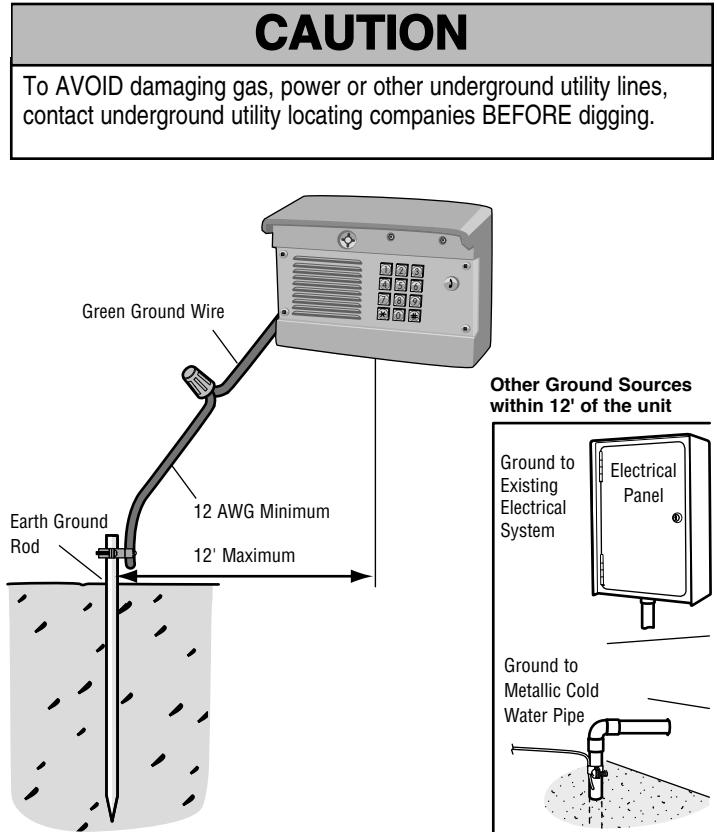

POWER WIRING

The 110 Vac outlet must be dedicated to the unit only. This outlet should be wired back to its own 10 Amp minimum circuit breaker. This will prevent two problems:

- Other equipment cannot introduce spikes, noise, surges, or dips into the power circuit.
- The system's operation will not be affected if any other equipment develops a short circuit across the power line.

Connect the transformer into a 110 Vac outlet after all connections have been made, any other type of outlet will cause damage to the system.

POWER WIRE TABLE

Distance	AC Power Wire Size
Under 30 feet	18 AWG
30 - 75 feet	18 AWG
75 - 150 feet	18 AWG
150 - 250 feet	16 AWG
250 - 500 feet	12 AWG

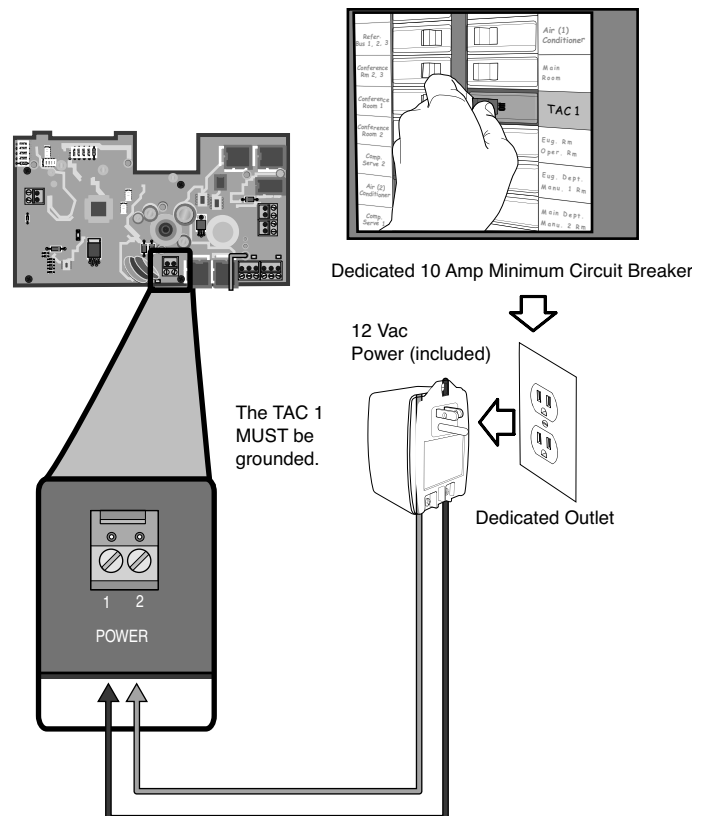

NOTE: Chamberlain is not responsible for conflicts between the information listed in the above table and the requirements of local building codes. The information is for suggested use only. Check local building codes before installation.

INSTALLATION >> PLUG THE TRANSFORMER INTO THE OUTLET, MOUNT THE UNIT AND SET THE UNIT MASTER CODE

PLUG THE TRANSFORMER INTO THE OUTLET

Plug the transformer into the 110 Vac outlet.

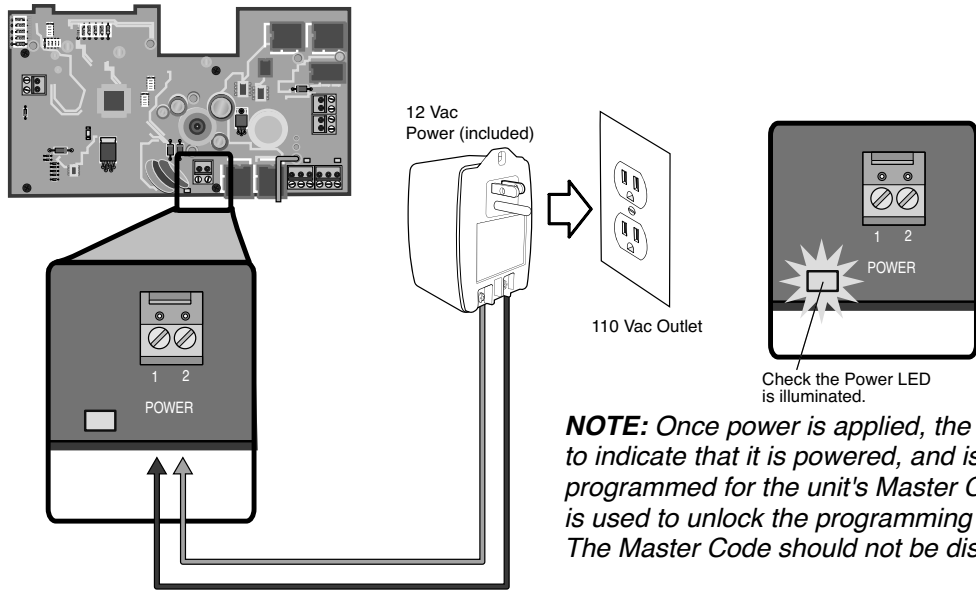

MOUNT THE UNIT

Mount the unit onto the back panel. Lock the unit with the key.

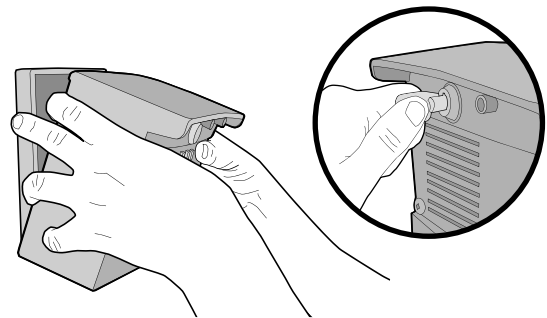

SET THE UNIT MASTER CODE

Enter  on the unit's keypad.

Enter 4 digit Master Code. Example: 1234.



Write down the Master Code and store in a secure location.

NOTE: The star (*) button acts as a cancel command that will end any call, programming or access code key sequence.

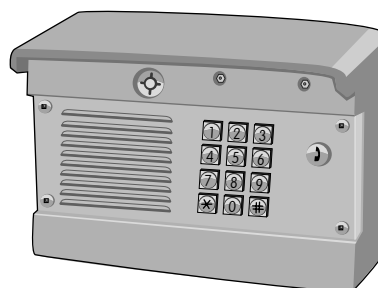

TESTING >> TEST THE GATE/DOOR RELAYS AND TEST THE TELEPHONE CONNECTIONS

TEST GATE/DOOR RELAYS

TEST RELAY 1

Enter 4 digit Master Code + 1 (Key)
The "1" Key indicates the Relay to be triggered.



NOTE: Relay 1 status indicator LED will illuminate (Blue) to show activity when triggered.

TEST RELAY 2

Enter 4 digit Master Code + 2 (Key)
The "2" Key indicates the Relay to be triggered.



NOTE: Relay 2 status indicator LED will illuminate (Blue) to show activity when triggered.

TEST THE TELEPHONE CONNECTIONS

1. Place a telephone call from the resident's telephone to verify it is operating properly, then hang up the phone.
2. Press the "Call" key on the unit's keypad. The telephone in the residence should ring.

NOTE: After the "Call" Button is pressed, the "Status" LED on the processor board will blink during transmission.

3. To test Relay 1 have someone answer the telephone and enter "*9" (Star + 9). The TAC1 will disconnect the call as soon as the relay is activated. To test Relay 2 have someone answer the telephone and enter "*5" (Star + 5). The TAC1 will disconnect the call as soon as the relay is activated.

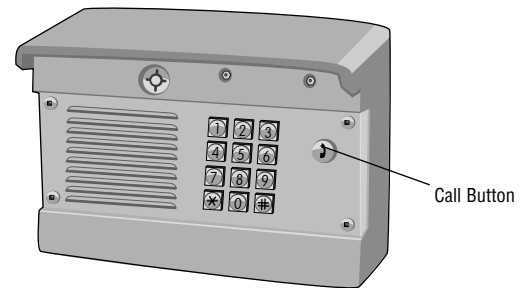

PROGRAMMING >> FROM THE TAC1 KEYPAD



GENERAL INSTRUCTION

NOTE: Use the STAR Key "*" to cancel any input.

Programming Instruction	Syntax	Keystrokes
General Programming	Master Code + Command	1234 + 1 (12,123)
Code Programming	Master Code + Command + Code	1234 +1(12) + 1234
Relay Programming	Master Code + Command + Setting	1234 + 123 + 1234
Level Adjustment	Master Code + Command + Setting	1234 + 12 + 1-3

NOTE: Keypad commands are to be entered in a single string to result in success (indicated by double high success tone). Stop and go keystrokes will result in negative tones (low single and triple fail tones).

CHANGE THE MASTER CODE

1. Enter the Master Code: [?] [?] [?] [?]
2. Enter the Program Code: [0] [9] The unit will beep.
3. Enter: [#] [#] [#]
4. Enter the New Master Code: [?] [?] [?] [?] The unit will beep.

Write down the Master Code and store in a secure location.

ENABLE PARALLEL RELAY OUTPUT (DEFAULT)

1. Enter the Master Code: [?] [?] [?] [?]
2. Enter the Program Code: [0] [2] [1]

ENABLE INDEPENDENT RELAY OUTPUT CONTROL

1. Enter the Master Code: [?] [?] [?] [?]
2. Enter the Program Code: [0] [2] [3]

ENABLE TELCO MODE

Telco Mode is using the main telephone line for the unit's communications to the house or complex.

1. Enter the Master Code: [?] [?] [?] [?]
2. Enter the Program Code: [0] [4]

ADJUST RELAY OUTPUT TIME (RELAY 1)

The amount of time (in seconds) the relay remains active. **Default level is 0.5 seconds.**

1. Enter the Master Code: [?] [?] [?] [?]
2. Enter the Program Code: [0] [2] [4]
3. Enter the Output Time (in seconds): [?] [?] [?] [?]

Example:

0000 = 0.5 Seconds (Minimum)
0010 = 10 Seconds
8000 = 8000 Seconds (Maximum)

ENABLE INTERCOM (NO TELCO) MODE

1. Enter the Master Code: [?] [?] [?] [?]
2. Enter the Program Code: [0] [3]

MICROPHONE SENSITIVITY

Allows the resident to hear the visitor at the unit, 1= Low, 2 = Medium and 3 = High. **Default level is 2.**

1. Enter the Master Code: [?] [?] [?] [?]
2. Enter the Program Code: [0] [7]
3. Enter the Volume Level: [1] or [2] or [3]

ADJUST RELAY OUTPUT TIME (RELAY 2)

The amount of time (in seconds) the relay remains active. **Default level is 0.5 seconds.**

1. Enter the Master Code: [?] [?] [?] [?]
2. Enter the Program Code: [0] [2] [5]
3. Enter the Output Time (in seconds): [?] [?] [?] [?]

Example:

0000 = 0.5 Seconds (Minimum)
0010 = 10 Seconds
8000 = 8000 Seconds (Maximum)

SPEAKER VOLUME

Allows the visitor to hear the resident at the unit, 1= Low, 2 = Medium and 3 = High. **Default level is 2.**

1. Enter the Master Code: [?] [?] [?] [?]
2. Enter the Program Code: [0] [6]
3. Enter the Volume Level: [1] or [2] or [3]

PROGRAMMING >> CODE SETUP AND CODE OPERATION



CODE SETUP

The unit's Master Code is for owner/administrator level commands. The User Codes allow users to activate and latch relays 1 and 2 and to transmit radio commands on channels one and two.

NOTE: The User Code cannot be the same as the Master Code.

ENTER A USER CODE NUMBERS

1. Enter the Master Code: - 2. Enter the Program Code: . The unit will beep.
- 3. Enter New User Code: .
- 4. Enter the Relay/Channel for the Code to control: or or no button is pressed.

NOTE: If no button is pressed in step 4, both relays/channels will activate simultaneously.

DELETE USER CODE NUMBERS

1. Enter the Master Code: - 2. Enter the Program Code: . The unit will beep.
- 3. Enter User Code to be Deleted: .

CODE OPERATION

MASTER CODE OPERATIONS

TRIGGER RELAY 1 (ONLY)

Enter the Master Code:

NOTE: Requires Relay 2 be in Independent Mode.

ENABLE VACATION (LOCK DOWN) MODE

Locks the system from all User Code activity.

1. Enter the Master Code: - 2. Enter the Program Code:

DISABLE VACATION (LOCK DOWN) MODE

1. Enter the Master Code: - 2. Enter the Program Code:

TRIGGER RELAY 1 AND CHANNEL 1

1. Enter the Master Code: - 2. Enter the Program Code:

TRIGGER RELAY 2 AND CHANNEL 2

1. Enter the Master Code: - 2. Enter the Program Code:

USER CODE OPERATIONS

TRIGGER PROGRAMMED RELAY/CHANNEL FOR USER CODE

Enter the User Code:

ENTER A TEMPORARY (1 SHOT) USER CODE NUMBER

The TAC1 holds 1 temporary User Code.

1. Enter the Master Code: - 2. Enter the Program Code: . The unit will beep.
- 3. Enter the Temporary User Code: .

ENGAGE PARTY MODE (RELAY 1)

Party Mode will latch Relay and trigger corresponding Channel.

1. Enter the Master Code: - 2. Enter the Program Code:
- To disengage party mode: Enter a valid Code into the TAC1 keypad or enter "#9" into the local telephone.

ENGAGE PARTY MODE (RELAY 2)

Party Mode will latch Relay and trigger corresponding Channel.

1. Enter the Master Code: - 2. Enter the Program Code:
- To disengage party mode: Enter a valid Code into the TAC1 keypad or enter "#5" into the local telephone.

PROGRAMMING >> FROM THE TELEPHONE



TELEPHONE PROGRAMMING

ENABLE INTERCOM MODE

Enter the Command Tone: * * 0 3

ENABLE TELCO MODE

Enter the Command Tone: * * 0 7

ENABLE STANDARD (LONG) RING TONE

Enter the Command Tone: * * 1 4

ENABLE ALTERNATE (DUAL) RING TONE (DEFAULT)

Enter the Command Tone: * * 1 5

ADJUST "PICK UP" RING COUNT

1. Enter the Command Tone: * * 1 0
2. Enter the Ring Count: 2 through 5

ENABLE ALTERNATE DTMF PROGRAMMING

This feature changes the first programming digit from * to #.

Enter the Command Tone: * * 1 3

DISABLE ALTERNATE DTMF PROGRAMMING

Enter the Command Tone: # * 1 6

CALL FORWARD PROGRAMMING

ENTER CALL FORWARDING TELEPHONE NUMBER

Enter the Command Tone:

* # #

VERIFY CALL FORWARDING NUMBER (VIA CALLER ID)

Enter the Command Tone: * * 0 6
Hang up the phone - Wait for the ring.

ERASE THE CALL FORWARDING NUMBER

Enter the Command Tone: * * # 8

ENABLE CALL FORWARDING

Enter the Command Tone: * * 0 1

DISABLE CALL FORWARDING

Enter the Command Tone: * * 0 2

PROGRAMMING >> TELEPHONE COMMANDS AND PROGRAM A PRE-INSTALLED LIFTMASTER RECEIVER

TELEPHONE COMMANDS

FROM LOCAL TELEPHONE

TRIGGER RELAY 1

Enter the Command Tone: * 9

TRIGGER RELAY 2

Enter the Command Tone: * 5

DISABLE "DO NOT DISTURB" MODE

Enter the Command Tone: * * 1 2

ENABLE PARTY MODE (RELAY 1)

Enter the Command Tone: * * 0 4

To disengage party mode: Enter "#9" into the local telephone.

ENABLE "DO NOT DISTURB" MODE

Enter the Command Tone: * * 1 1

FROM FORWARDED TELEPHONE

ACCEPT CALL FROM UNIT ON REMOTE TELEPHONE

Enter the Command Tone: 0

TRIGGER RELAY 1

Enter the Command Tone: * 9

TRIGGER RELAY 2

Enter the Command Tone: * 5

PROGRAM A PRE-INSTALLED LIFTMASTER RECEIVER

When either of the relays is activated the TAC1 will emit a 315 MHz signal to the receiver.

1. Locate the receiver. Refer to the gate or door operator manual for information about the location of the Learn button.
2. Press and release the Learn button on the receiver. The Indicator Light will light for 30 seconds indicating that receiver is in Learn Mode.
3. Within 30 seconds enter Master Code on the TAC1 keypad.
4. Press "1" key on the TAC1 keypad. The Indicator Light on the receiver will blink 3 times indicating programming is successful.

NOTE: An error tone will be heard for 3 consecutive activations only. After the third activation the unit assumes that the unit has been replaced with the receiver.

Repeat Steps 2-4 for each LiftMaster door or gate operator that will be controlled (2 maximum).

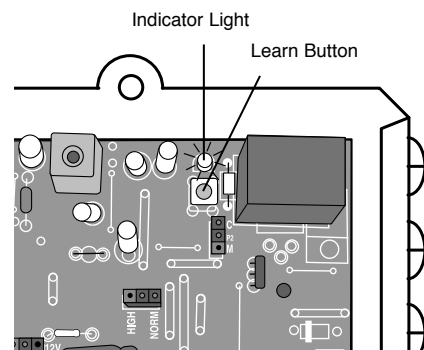

ERASE ALL CONTROL CODES

Press and hold the Learn button on the receiver until the Indicator Light turns off indicating that the receiver memory is clear (about 6 seconds).

PROGRAMMING >> QUICK REFERENCE

KEYPAD PROGRAMMING

Programming Number	Description of Task	Factory Setting	Programming Procedure
1	Trigger Relay One and Radio Channel One		Master Code (4 digits) + 1
2	Trigger Relay Two and Radio Channel Two		Master Code (4 digits) + 2
7	Delete User Code		Master Code (4 digits) + 7 + User Code that is to be deleted (4 digits)
9	Enter User Code		Master Code (4 digits) + 9 + New User Code (4 digits) + Relay/Channel Associated with the User Code (1 or 2)
03	Enable Intercom (No-Telco) Mode	Enabled	Master Code (4 digits) + 03
04	Enable Telco Mode		Master Code (4 digits) + 04
06	Speaker Volume	Level 2	Master Code (4 digits) + 06 + Volume Level (1=Low, 2=Medium or 3=High)
07	Microphone Sensitivity	Level 2	Master Code (4 digits) + 07 + Volume Level (1=Low, 2=Medium or 3=High)
09	Change the Master Code		Master Code (4 digits) + 09 + ### + New Master Code (4 digits)
51	Create Temporary (1 Shot) Code		Master Code (4 digits) + 51 + New Temporary (1 Shot) Code (4 digits)
52	Enable Vacation (Lock Down) Mode	Disabled	Master Code (4 digits) + 52
53	Disable Vacation (Lock Down) Mode		Master Code (4 digits) + 53
54	Engage Party Mode (Relay 1)	Disabled	Master Code (4 digits) + 54
56	Engage Party Mode (Relay 2)	Disabled	Master Code (4 digits) + 56
021	Enable Parallel Relay Output	Enabled	Master Code (4 digits) + 021
023	Enable Independent Relay Output Control	Disabled	Master Code (4 digits) + 023
024	Adjust Relay Output Time (Relay 1)	.5 Seconds	Master Code (4 digits) + 024 + Relay Output Time (0000-8000 Seconds) NOTE: Relay output time is ALWAYS 4 digits.
025	Adjust Relay Output Time (Relay 2)	.5 Seconds	Master Code (4 digits) + 025 + Relay Output Time (0000-8000 Seconds) NOTE: Relay output time is ALWAYS 4 digits.

DIRECT COMMANDS FROM THE TAC1 KEYPAD

Keystrokes	Action
User Code + 1	Triggers Relay 1
User Code + 2	Triggers Relay 2

AUDIO FEEDBACK FROM THE TAC1:

- 1 Low Tone = Failure
- 2 Tone Beep = Valid sequence
- 3 Tone Beep = Error or invalid sequence

NOTE: Use the STAR Key "*" to cancel any input.

NOTE: Keypad commands are to be entered in a single string to result in success (indicated by double high success tone). Stop and go keystrokes will result in negative tones (low single and triple fail tones).

PROGRAMMING >> QUICK REFERENCE

TELEPHONE PROGRAMMING

Programming Number	Description of Task	Factory Setting	Programming Procedure
**01	Enable Call Forwarding	Disabled	**01
**02	Disable Call Forwarding		**02
**03	Enable Intercom Mode	Disabled	**03
**06	Verify Call Forwarding Number (Via Caller ID)	Disabled	**06
**07	Enable Telco Mode	Disabled	**07
**#8	Erase Call Forwarding Number		**#8
**10	Adjust "Pick-Up" Ring Count		**10 + Ring Count (2-5)
**13	Enable Alternate DTMF Programming	Disabled	**13
**14	Enable Standard (Long) Ring Tone		**14
**15	Enable Alternate (Dual) Ring Tone	Enabled	**15
#*16	Disable Alternate DTMF Programming		**16
*# Call Forwarding Number #	Enter Call Forwarding Telephone Number		*# +Telephone Number (Up to 14 digits) + #

DIRECT COMMANDS FROM THE LOCAL TELEPHONE

Programming Number	Description of Task	Factory Setting	Programming Procedure
*5	Triggers Relay 2		*5
*9	Triggers Relay 1		*9
**04	Enable Party (Latched) Mode Relay 1		**04
**05	Disable Party (Latched) Mode Relay 1		
**11	Enable "Do Not Disturb" Mode	Disabled	**11
**12	Disable "Do Not Disturb" Mode		**12

DIRECT COMMANDS FROM THE FORWARDED TELEPHONE

Programming Number	Description of Task	Factory Setting	Programming Procedure
0	Accepts Call From The Unit		0
*5	Triggers Relay 2		*5
*9	Triggers Relay 1		*9

NOTE: Use the STAR Key "*" to cancel any input.

NOTE: Keypad commands are to be entered in a single string to result in success (indicated by double high success tone). Stop and go keystrokes will result in negative tones (low single and triple fail tones).

TAC1 MASTER CODE

Write down the Master Code and store in a secure location.

--	--	--	--

LIMITED WARRANTY

The Chamberlain Group, Inc. ("Seller") warrants to the first purchaser of this product, for the structure in which this product is originally installed, that it is free from defect in materials and/or workmanship for a period of one year from the date of purchase.

The proper operation of this product is dependent on your compliance with the instructions regarding installation, operation, maintenance and testing. Failure to comply strictly with those instructions will void this limited warranty in its entirety.

If, during the limited warranty period, this product appears to contain a defect covered by this limited warranty, call 1-800-528-2806 before dismantling this product. Then send this product, pre-paid and insured, to our service center for warranty replacement. Products returned to Seller for warranty replacement, which upon receipt by Seller are confirmed to be defective and covered by this limited warranty, will be replaced (at Seller's sole option) at no cost to you and returned pre-paid. Defective parts will be replaced with new or factory-rebuilt parts at Seller's sole option.

THIS LIMITED WARRANTY IS IN LIEU OF ANY OTHER WARRANTIES, EXPRESS OR IMPLIED, INCLUDING ANY IMPLIED WARRANTY OF MERCHANTABILITY OR FITNESS FOR A PARTICULAR PURPOSE OR OTHERWISE, AND OF ANY OTHER OBLIGATIONS OR LIABILITY ON SELLER'S PART. THIS LIMITED WARRANTY DOES NOT COVER NON-DEFECT DAMAGE, DAMAGE CAUSED BY IMPROPER INSTALLATION, OPERATION OR CARE (INCLUDING, BUT NOT LIMITED TO ABUSE, MISUSE, FAILURE TO PROVIDE REASONABLE AND NECESSARY MAINTENANCE, UNAUTHORIZED REPAIRS OR ANY ALTERATIONS TO THIS PRODUCT), LABOR CHARGES FOR REINSTALLING A REPAIRED OR REPLACED UNIT, PROBLEMS RELATED TO INTERFERENCE, OR REPLACEMENT OF BATTERIES.

UNDER NO CIRCUMSTANCES SHALL SELLER BE LIABLE FOR CONSEQUENTIAL, INCIDENTAL OR SPECIAL DAMAGES ARISING IN CONNECTION WITH USE, OR INABILITY TO USE, THIS PRODUCT. IN NO EVENT SHALL SELLER'S LIABILITY FOR BREACH OF WARRANTY, BREACH OF CONTRACT, NEGLIGENCE OR STRICT LIABILITY EXCEED THE COST OF THE PRODUCT COVERED HEREBY. NO PERSON IS AUTHORIZED TO ASSUME FOR US ANY OTHER LIABILITY IN CONNECTION WITH THE SALE OF THIS PRODUCT.

Some States do not allow the exclusion or limitation of consequential, incidental or special damages, so the above limitation or exclusion may not apply to you. This limited warranty gives you specific legal rights, and you may also have other rights which vary from state to state.

**FOR TECHNICAL SUPPORT DIAL OUR TOLL FREE NUMBER:
1-800-528-2806**

www.liftmaster.com

NOTICE: To comply with FCC and or Industry Canada rules (IC), adjustment or modifications of this receiver and/or transmitter are prohibited, except for changing the code setting or replacing the battery. THERE ARE NO OTHER USER SERVICEABLE PARTS.
Tested to Comply with FCC Standards FOR HOME OR OFFICE USE. Operation is subject to the following two conditions: (1) this device may not cause harmful interference, and (2) this device must accept any interference received, including interference that may cause undesired operation.

This document is protected by copyright and may not be copied or adapted without the prior written consent of The Chamberlain Group. This documentation contains information proprietary to The Chamberlain Group and such information may not be distributed without the prior written consent of The Chamberlain Group. The software and firmware included in the Chamberlain product as they relate to this documentation are also protected by copyright and contain information proprietary to The Chamberlain Group.