

S800H

24V Underground Hydraulic Swing Gate Operator

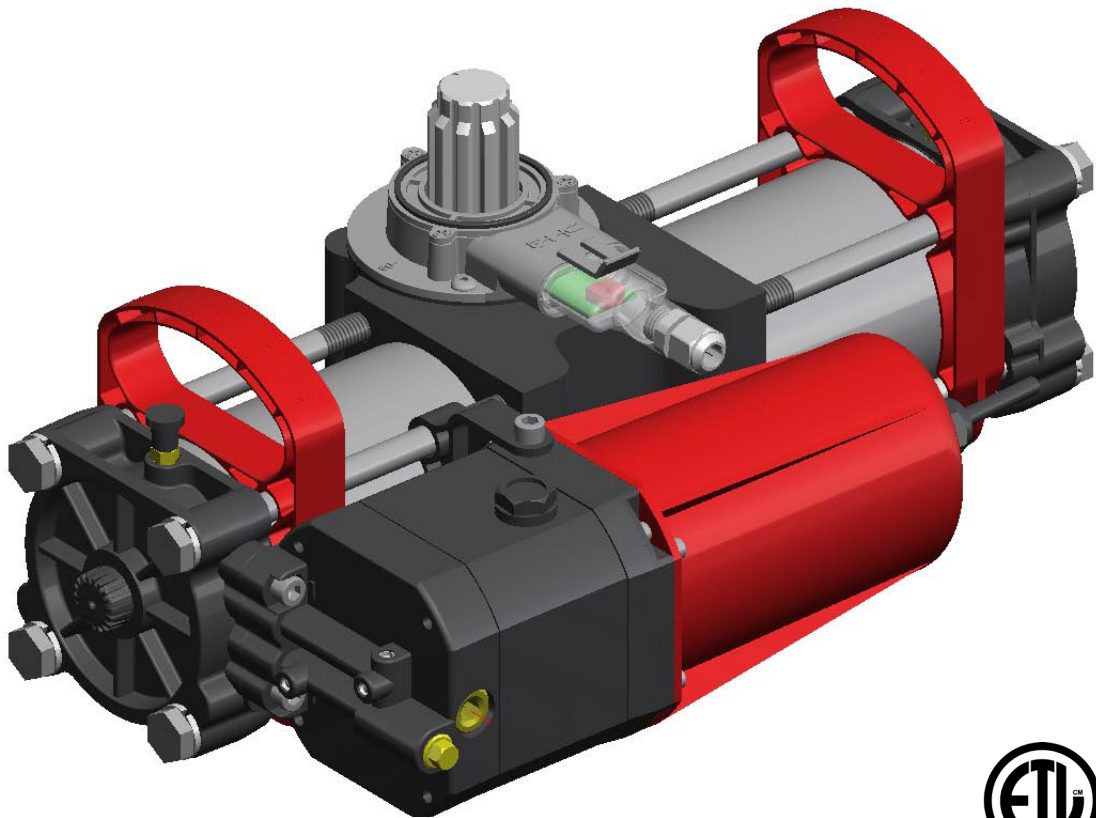

Intertek

UL325 - UL991

FAAC International Inc.
Headquarter & East Coast Operations
5151 Sunbeam Road
Suites 9-11
Jacksonville, FL 32257
Tel. 866 925 3222
www.faacusa.com

FAAC International Inc.
West Coast Operations
357 South Acacia Avenue
Unit 357
Fullerton, CA 92831
Tel. 800 221 8278

FAAC

CONTENTS

IMPORTANT SAFETY INFORMATION	3
Important Safety Instructions	3
Important Installation Instructions	3
General Safety Precautions	4
UL325 Gate Operator Classifications	5
Installing the Warning Signs	5
1. DESCRIPTION AND CHARACTERISTICS	6
1.1 TECHNICAL SPECIFICATIONS	6
1.2 ELECTRICAL LAYOUT	6
2. INSTALL THE LOAD BEARING BOX	7
3. INSTALL THE OPERATOR	9
3.1 INTERNAL MECHANICAL POSITIVE STOPS	11
3.2 ADJUSTMENT OF THE TRAVEL-LIMIT STOPS	11
3.3 FINAL STEPS	11
4. MANUAL OPERATIONS	12
4.1 BUILT IN HYDRAULIC RELEASE	12
4.2 EXTERNAL IN HYDRAULIC RELEASE	12
5. MAINTENANCE	13
5.1 BLEEDING OPERATIONS	13
7.2 MECHANICAL EMERGENCY RELEASE	13
6. ENCODER CONNECTION	14
7. S800H PARTS DIAGRAM	16
E024U CONTROL BOARD AND LIMITED WARRANTY	A2 - A18



Read this instruction manual before you begin installing the product.
 = Information regarding personal safety and proper maintenance of the product.

IMPORTANT SAFETY INFORMATION

Important Safety Instructions

WARNING - TO REDUCE THE RISK OF SEVERE INJURY OR DEATH:

- READ AND FOLLOW ALL INSTRUCTIONS.
- Never let children operate or play with the gate controls. Keep remote controls away from children.
- Always keep people and objects away from the gate. **NO ONE SHOULD CROSS THE PATH OF A MOVING GATE.**
- Test the gate operator monthly. The gate **MUST** reverse on contact with a rigid object or when an object activates a non-contact sensor. If necessary, adjust the force or the limit of travel and then retest the gate operator. Failure to properly adjust and retest the gate operator can increase the risk of injury or death.
- Use the manual release mechanism only when the gate is not moving.
- **KEEP GATE PROPERLY MAINTAINED.** Have a qualified service person make repairs to gate hardware.
- The entrance is for vehicles only. Pedestrians must use a separate entrance.
- **SAVE THESE INSTRUCTIONS.**

Important Installation Instructions

1. Install the gate operator only when the following conditions have been met:
 - The operator is appropriate for the type and usage class of the gate.
 - All openings of a horizontal slide gate have been guarded or screened from the bottom of the gate to a minimum of 4 feet (1.25 m) above the ground to prevent a 2.25 inch (55 mm) diameter sphere from passing through openings anywhere in the gate or through that portion of the adjacent fence that the gate covers when in the open position.
 - All exposed pinch points are eliminated or guarded.
 - Guarding is supplied for exposed rollers.
2. The operator is intended for installation on gates used by vehicles only. Pedestrians must be provided with a separate access opening.
3. To reduce the risk of entrapment when opening and closing, the gate must be installed in a location that allows adequate clearance between the gate and adjacent structures. Swinging gates shall not open outward into public access areas.
4. Before installing the gate operator, ensure that the gate has been properly installed and that it swings freely in both directions. Do not over-tighten the operator clutch or pressure relief valve to compensate for a damaged gate.
5. User controls must be installed at least 6 feet (1.83 m) away from any moving part of the gate and located where the user is prevented from reaching over, under, around or through the gate to operate the controls. Controls located outdoors or those that are easily accessible shall have security features to prevent unauthorized use.
6. The Stop and/or Reset buttons must be located within line-of-sight of the gate. Activation of the reset control shall not cause the operator to start.
7. All warning signs and placards must be installed and easily seen within visible proximity of the gate. A minimum of one warning sign shall be installed on each side of the gate.
8. For gate operators that utilize a non-contact sensor (photo beam or the like):
 - See instructions on the placement of non-contact sensors for each type of application.
 - Exercise care to reduce the risk of nuisance tripping, such as when a vehicle trips the sensor while the gate is still moving.
 - Locate one or more non-contact sensors where the risk of entrapment or obstruction exists, such as at the reachable perimeter of a moving gate or barrier.
 - Use only FAAC "Photobeam" photoelectric eyes to comply with UL325.

Important Installation Instructions (continued)

9. For gate operators that utilize a contact sensor (edge sensor or similar):
 - Locate one or more contact sensors where the risk of entrapment or obstruction exists, such as at the leading edge, trailing edge, and post mounted both inside and outside of a vehicular horizontal slide gate
 - Locate one or more contact sensors at the bottom edge of a vehicular vertical lift gate.
 - Locate one or more contact sensors at the bottom edge of a vertical barrier (arm).
 - Locate one or more contact sensors at the pinch point of a vehicular vertical pivot gate.
 - Locate hard-wired contact sensors and wiring so that communication between sensor and gate operator is not subjected to mechanical damage.
 - Locate wireless contact sensors, such as those that transmit radio frequency (RF) signals, where the transmission of signals are not obstructed or impeded by building structures, natural landscaping or similar hindrances. Wireless contact sensors shall function under their intended end-use conditions.
 - Use only FAAC MSE MO, CN60 or M60 edge sensors.

**General Safety Precautions****Gate Construction**

Vehicular gates should be constructed and installed in accordance with ASTM F2200: Standard Specification for Automated Vehicular Gate Construction.

For more information, contact ASTM at: www.astm.org

Installation

- If you have any questions or concerns regarding the safety of the gate operating system, do not install the operator and consult the manufacturer.
- The condition of the gate structure itself directly affects the reliability and safety of the gate operator.
- Only qualified personnel should install this equipment. Failure to meet this requirement could cause severe injury and/or death, for which the manufacturer cannot be held responsible.
- The installer must provide a main power switch that meets all applicable safety regulations.
- It is extremely unsafe to compensate for a damaged gate by increasing hydraulic pressure.
- Install devices such as reversing edges and photo beams to provide better protection for personal property and pedestrians. Install reversing devices that are appropriate to the gate design and application.
- Before applying electrical power, ensure that voltage requirements of the equipment correspond to the supply voltage. Refer to the label on your gate operator system.

Usage

- Use this equipment only in the capacity for which it was designed. Any use other than that stated should be considered improper and therefore dangerous.
- The manufacturer cannot be held responsible for damage caused by improper, erroneous or unreasonable use.
- If a gate system component malfunctions, disconnect the main power before attempting to repair it.
- Do not impede the movement of the gate, you may injure yourself or damage the gate system as a result.
- This equipment may reach high thermal temperatures during normal operation, therefore use caution when touching the external housing of the gate operator.
- Use the manual release mechanism according to the procedures presented in this manual.
- Before performing any cleaning or maintenance operations, disconnect power to the equipment.
- All cleaning, maintenance or repair work must be performed by qualified personnel.

UL325 Gate Operator Classifications

RESIDENTIAL VEHICULAR GATE OPERATOR CLASS I

A vehicular gate operator system intended for use in a single family dwelling, garage or associated parking area.

COMMERCIAL / GENERAL ACCESS VEHICULAR GATE OPERATOR CLASS II

A vehicular gate operator system intended for use in commercial locations or buildings such as multi-family housing units (five or more single family units), hotels, parking garages, retail stores or other buildings that service the general public.

INDUSTRIAL / LIMITED ACCESS VEHICULAR GATE OPERATOR CLASS III

A vehicular gate operator system intended for use in industrial locations or buildings such as factories, loading docks or other locations not intended to service the general public.

RESTRICTED ACCESS VEHICULAR GATE OPERATOR CLASS IV

A vehicular gate operator system intended for use in guarded industrial locations or buildings such as airport security areas or other restricted access locations that do not service the general public, and in which unauthorized access is prevented via supervision by security personnel.

Installing the Warning Signs

This FAAC swing gate operator is supplied with two warning signs to alert people that a possible hazard exists and that appropriate actions should be taken to avoid the hazard or to reduce exposure to it.

Permanently install one warning sign on each side of the gate so they are fully visible to traffic and pedestrians.

Use appropriate hardware such as metal screws (not supplied) to permanently install each warning sign.



Model S800H 24V Underground Hydraulic Swing Gate Operator

1. DESCRIPTION AND CHARACTERISTICS

FAAC S800H is an integrated hydraulic automated system, permitting vehicle access through swing leaf gates which, when installed invisibly in the ground, does not alter the appearance of the gate. The model with a hydraulic lock device (CBAC) does not require the installation of an electrical lock, as it guarantees the mechanical locking of the leaf when the motor is not operating. The model without a hydraulic lock device always requires one or more electrical locks to ensure the leaf is mechanically locked. The S800H automated systems were designed and built to automate swing leaf gates. Do not use for any other purpose.

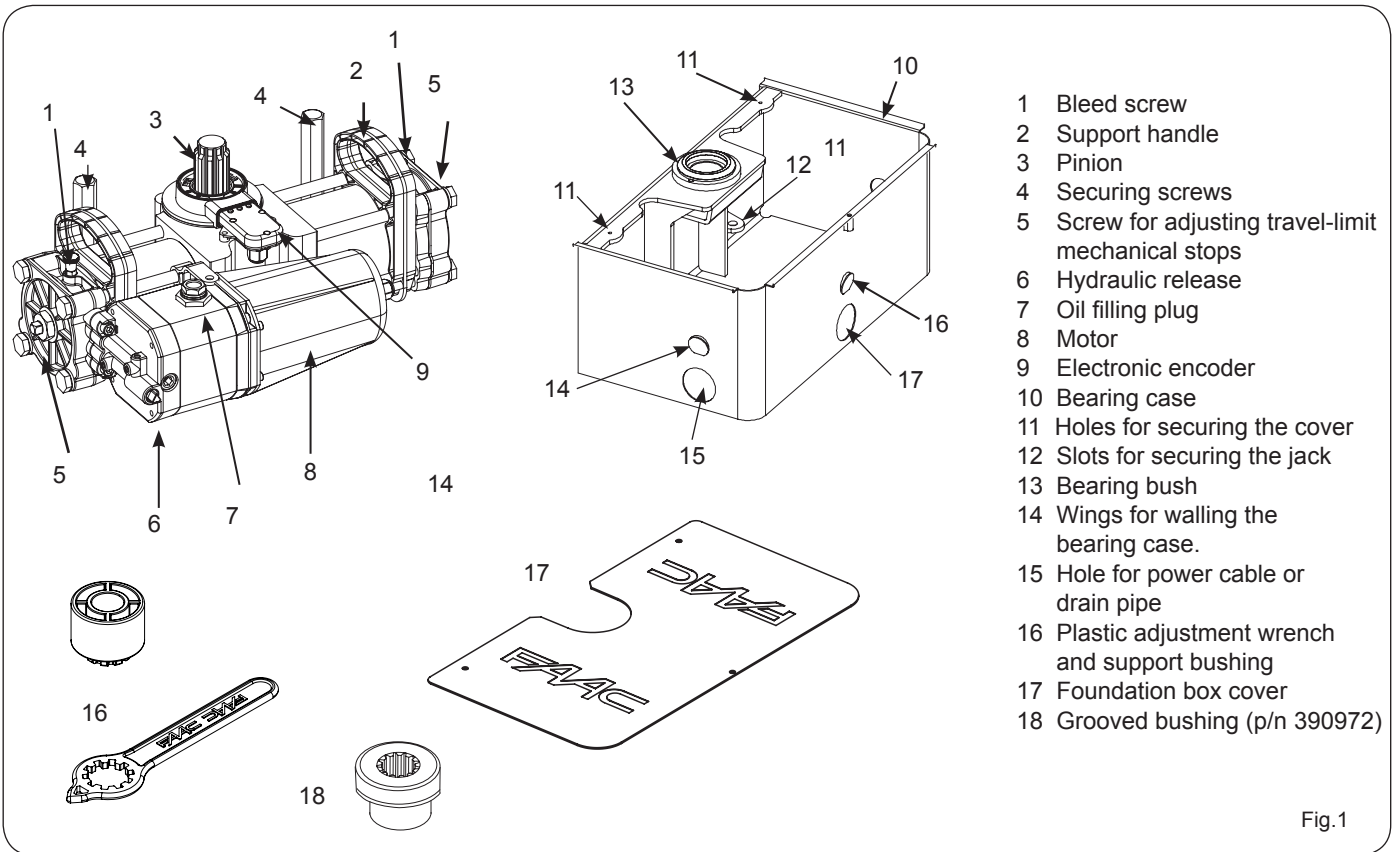

Fig.1

1.1 TECHNICAL SPECIFICATIONS

TECHNICAL SPECIFICATIONS	CBAC OPERATOR	SB OPERATOR
Power supply (V dc)	24	
Absorbed power (W)	60	
Protection class	IP 67	
Type of oil	FAAC HP OIL	
Operating ambient temperature	-4°F +131°F	
Hydraulic lock	Built in	Not available
Max. torque (lbf.ft)	450	
Angular speed (°/sec)	8.2	
Duty cycle at 68 °F	Continuous	
Class of Operation	Residential, Commercial	
Max opening angle	113° (S800H 100°) 187° (S800H 180°)	
Leaf max. length (ft)	13	16
Leaf max. weight (lb)	1760	

1.2 ELECTRICAL LAYOUT

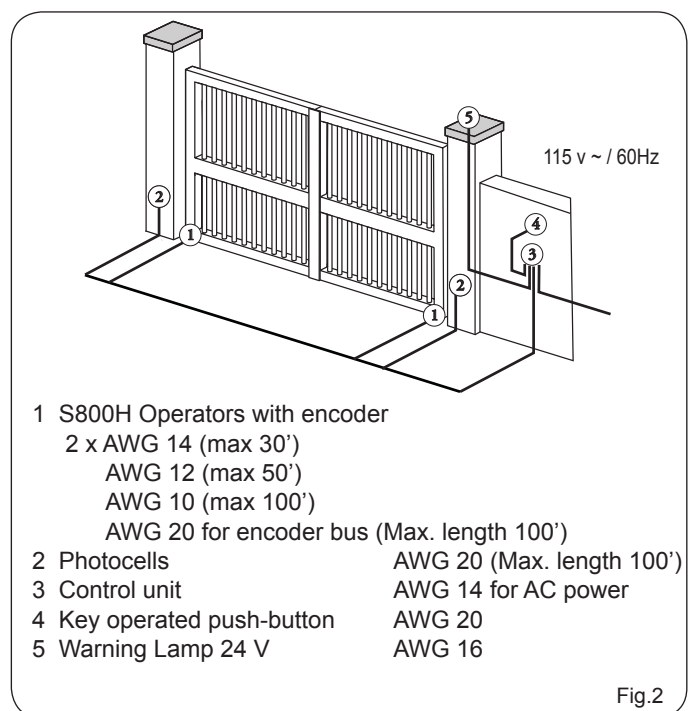
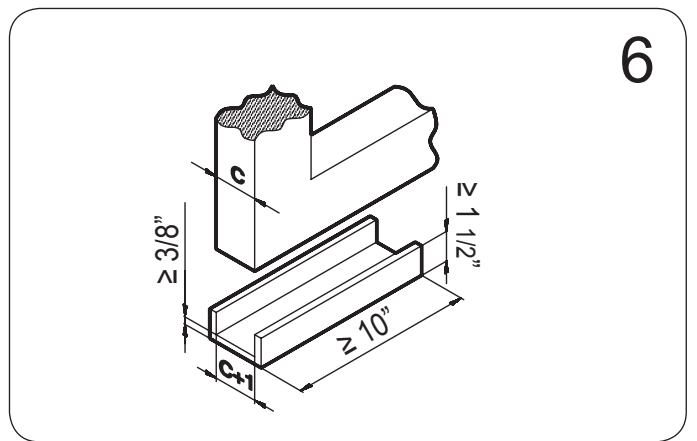
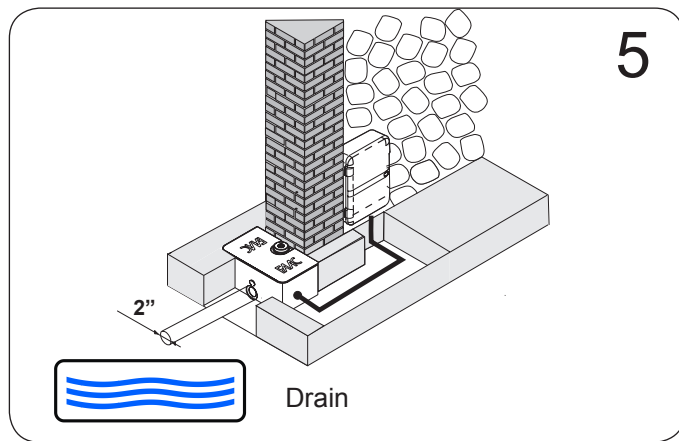
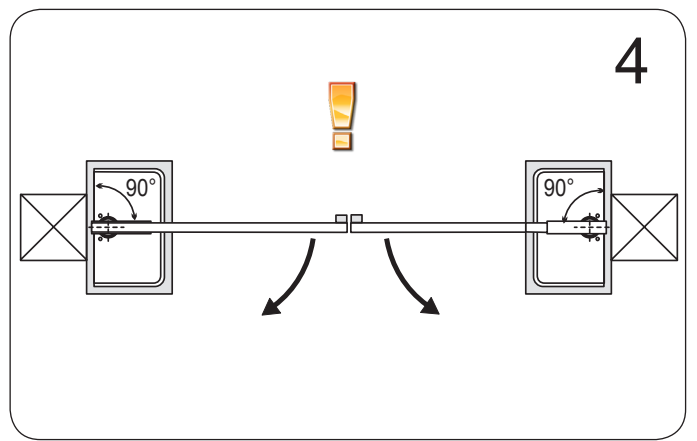
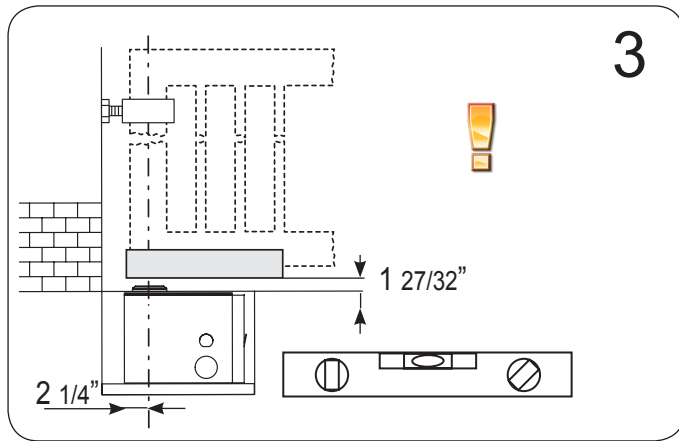
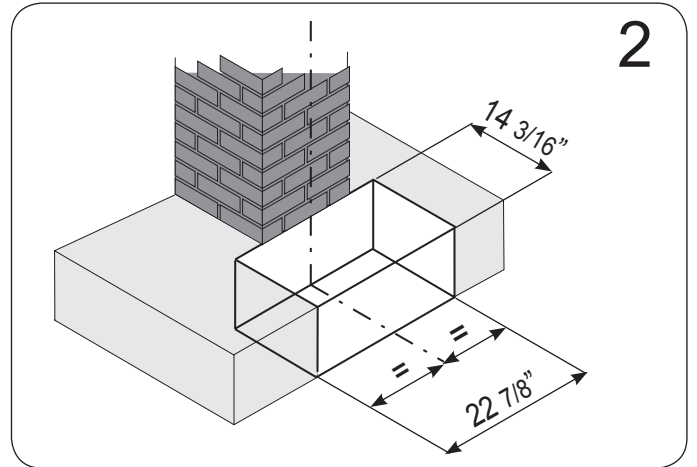
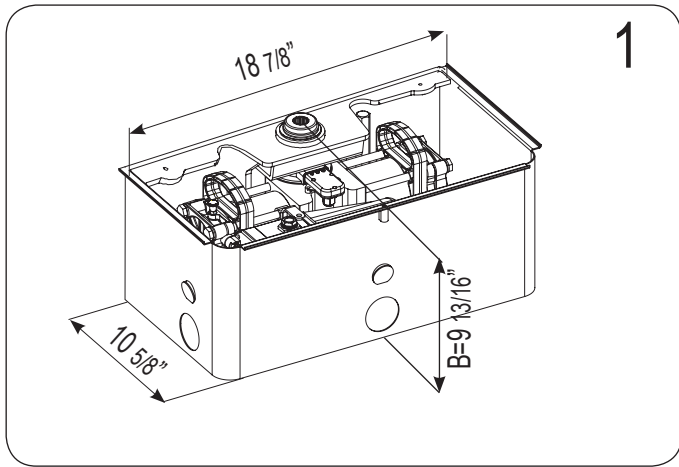

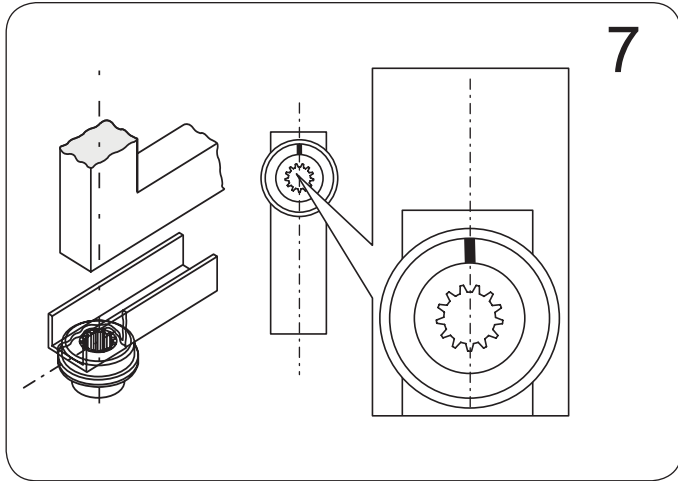

Fig.2

2. INSTALL THE LOAD BEARING BOX



 Dimensions in inches



TO ENSURE CORRECT INSTALLATION,
THE LEAF ROTATION AXIS MUST BE
PERFECTLY ALIGNED WITH THE OPE-
RATOR (Fig. 7)

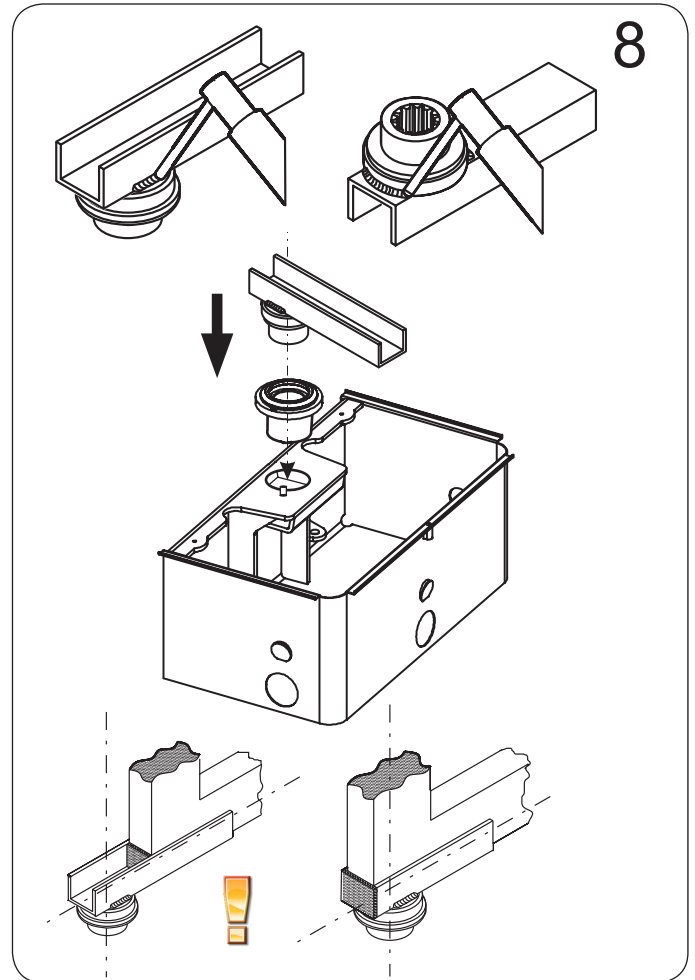

3. INSTALL THE OPERATOR

- 1) Move the gate to its open position.
- 2) Referring to the instructions in chapter 4.1, hydraulically release the operator, using the release screw (Fig. 3 ref.1)

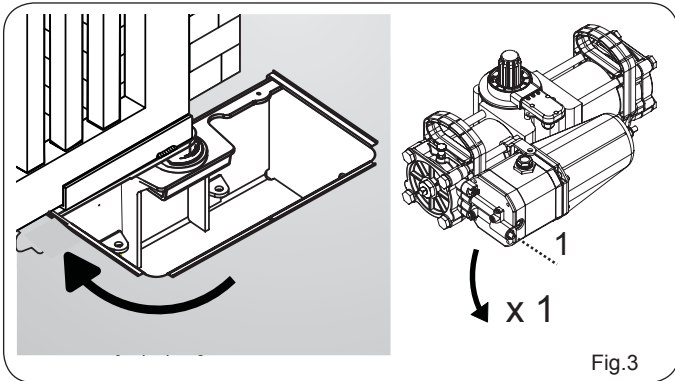

- 3) On the operator, unscrew the plug (Fig.4 ref. A) of the screw of the closing travel limit device (Fig.4 ref. 1) and check if the screw is completely tight.

- 4) Unscrew the closing travel limit screw (Fig.4 ref. B) by one turn (**IMPORTANT FOR CORRECT COUPLING OF THE PINION-GROOVED BUSHING DURING INSTALLATION**).

- 5) Turn the operator pinion with the supplied wrench (Fig. 5 ref. 1), **in the gate closing direction** as shown in Fig.5, up to the internal stop point of the piston, and remove the wrench.

- 6) **Without moving the pinion**, insert the supplied wrench on the operator as shown in Fig.6, and make sure that it indicates 0 (ZERO) on the operator's plastic panel (Fig.6 ref.1). If necessary rotate the pinion. (**IMPORTANT FOR CORRECT COUPLING OF THE PINION-GROOVED BUSH DURING INSTALLATION**).

TURN THE KEY UNTILL IT REACHES THE MECHANICAL STOP-POINT AND REMOVE IT FROM THE PINION

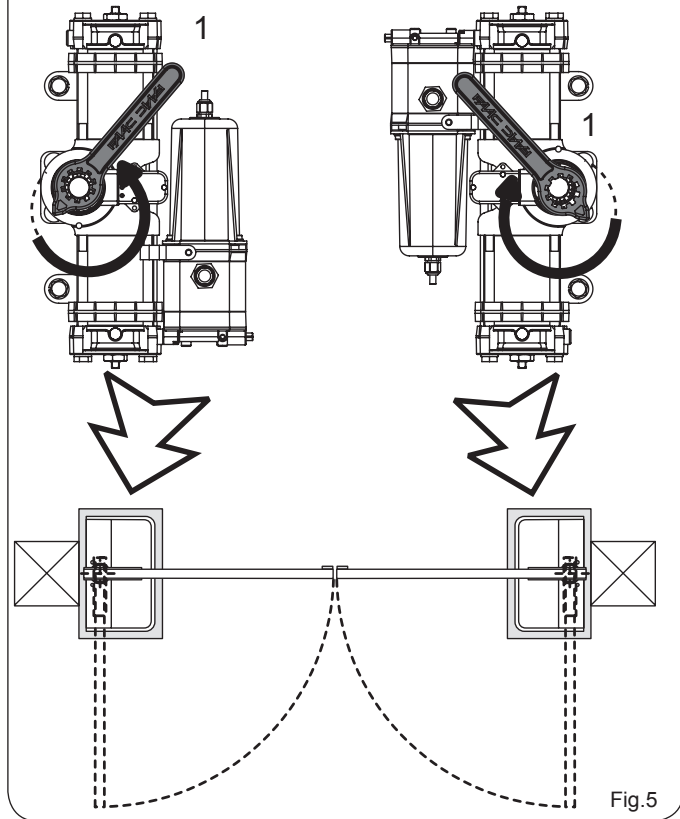

INSERT THE KEY WITHOUT MOVING THE PINION AND CHECK IF IT INDICATES ZERO

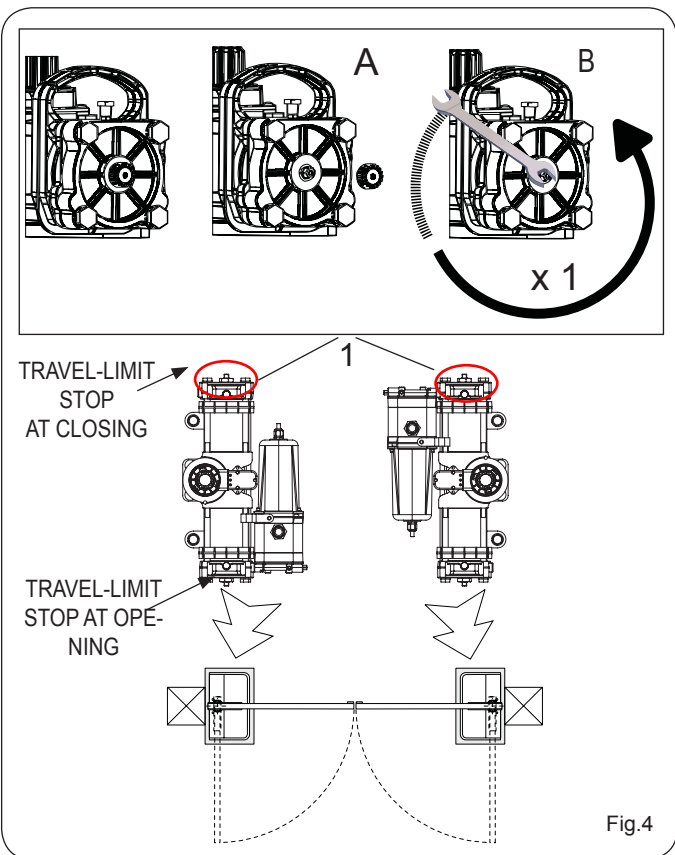
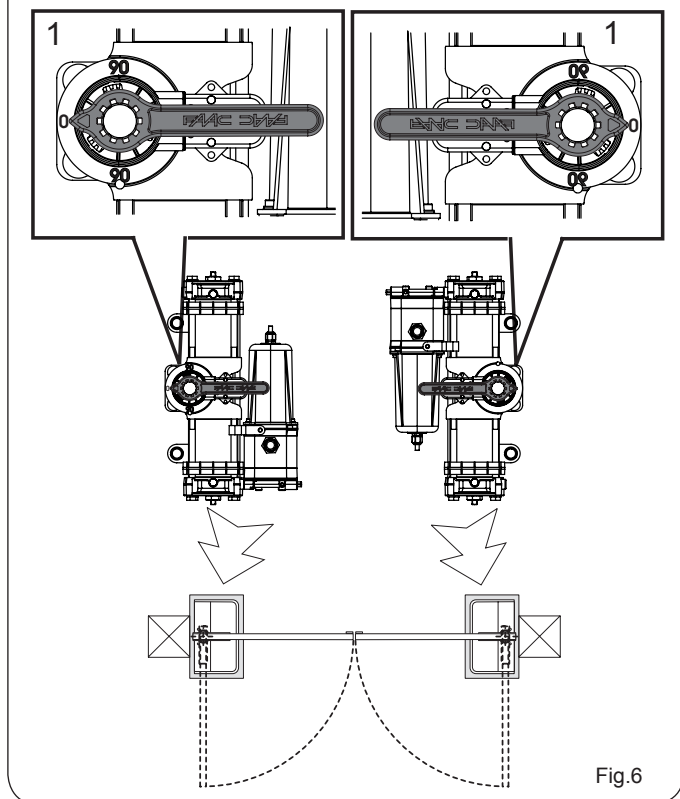

NOTE: if necessary, lightly tighten the closing travel-limit screw
 7) Turn the operator pinion with the supplied wrench until the mark point to 90° and then remove the wrench (see Fig. 7)

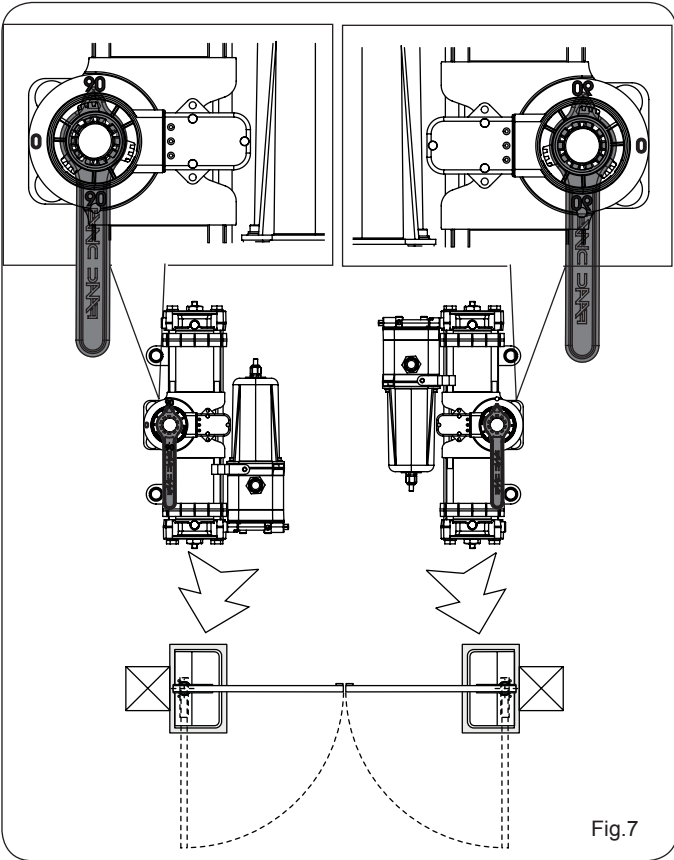

Fig.7

8) Grease the pinion and insert the operator in the load bearing box as shown in Fig.8-9,
 9) Raise the operator with its handles (Fig.10 ref. A), inserting the pinion in the grooved bushing of the bearing case. To facilitate the operation, slightly rotate the operator until coupling takes place.

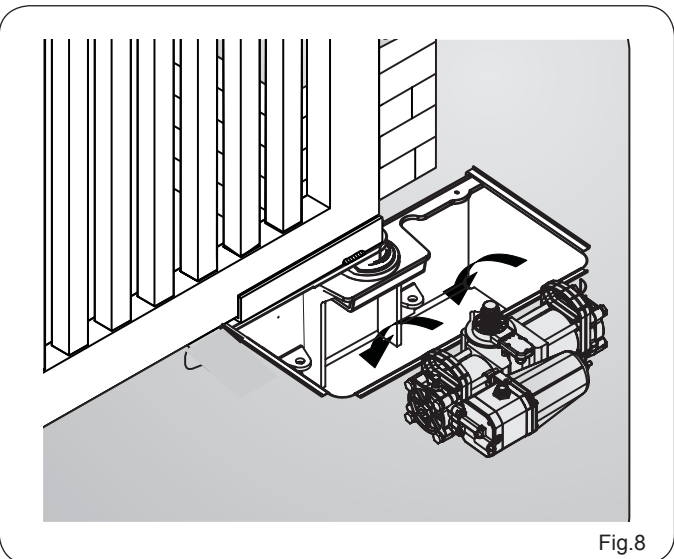

Fig.8

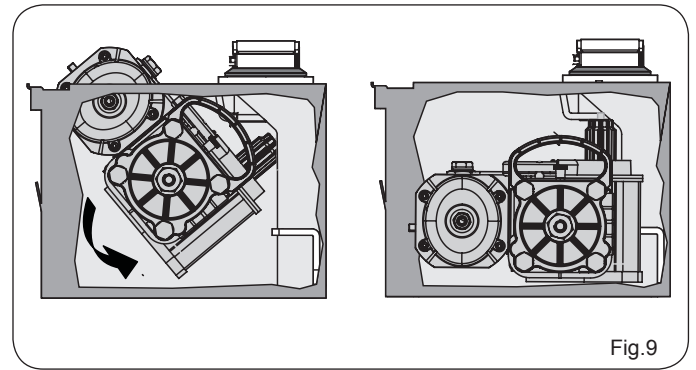

Fig.9

10) Place the supplied plastic wrench with the spacer under the operator, as shown in figure 10 ref. B, C
 12) Insert and screw in the fastening screws with the supplied lockwasher as shown in Fig. 10 ref. C, in order to secure the operator to the load bearing box as shown in Fig. 11.
 13) Close the gate and check if the closing travel-limit stop is correctly positioned; if necessary, adjust the travel-limit stop, referring to the instructions in paragraph 3.4.
 14) Open the gate and check if the opening travel-limit stop is correctly positioned; if necessary, adjust the travel-limit stop, referring to the instructions in paragraph 3.4.
 15) Hydraulically re-lock the operator as per instructions in chapter 4

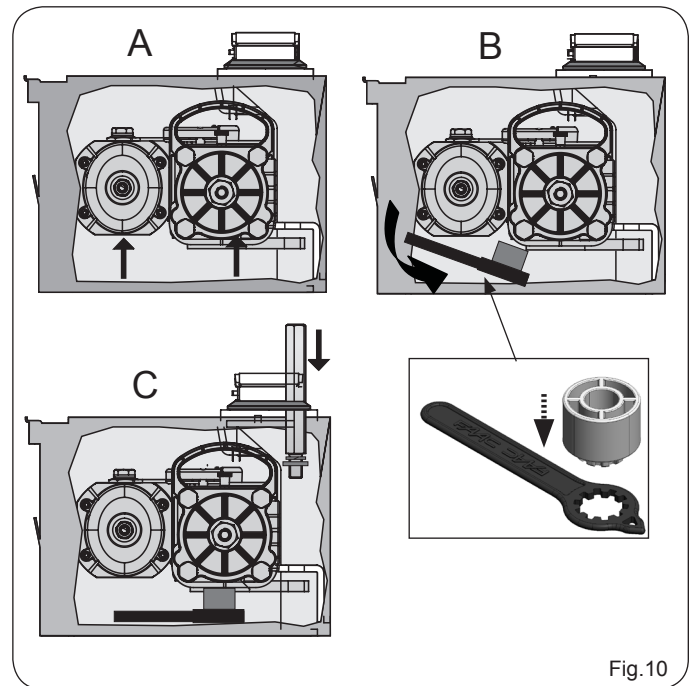

Fig.10

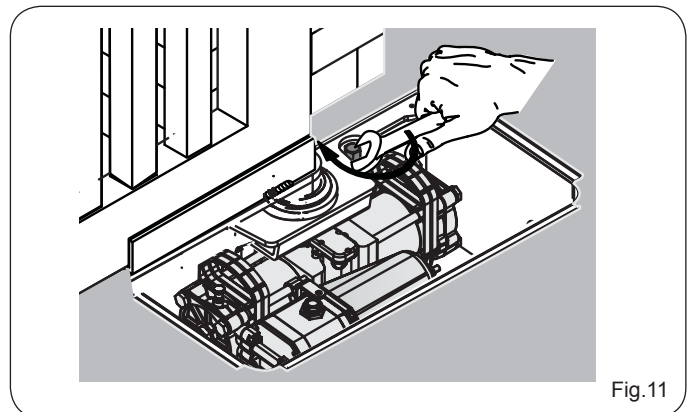

Fig.11

3.1 INTERNAL MECHANICAL POSITIVE STOPS

The S800H operator is supplied standard with internal opening and closing mechanical stops. This is to facilitate the installation operations because there is no need to build external mechanical stops.

The mechanical travel-limit stops (POSITIVE STOPS) can be adjusted in the last 30° of the operator's MAXIMUM travel, at both opening and closing.

FAAC SUPPLIES THE TRAVEL LIMIT DEVICES TOTALLY OPEN (MAXIMUM PINION ROTATION ANGLE).

3.2 ADJUSTMENT OF THE TRAVEL-LIMIT STOPS

- 1) Hydraulically release the operator. (See chapter 4.1)
- 2) Close the leaf, manually taking it into its closed position.
- 3) Unscrew the cap (Fig.12 ref.A) of the closing travel-limit screw (Fig.12 ref.1)
- 4) UNSCREW the travel-limit stop screw (Fig.12 ref.B) at closing (Fig.12 ref.1), until the leaf begins to move.
- 5) Fasten the supplied U-bracket (Fig.13) on the travel-limit stop screw.
- 6) Open the leaf, manually taking it into its opening position.
- 7) Unscrew the cap of the screw (Fig.12 ref.A) of the opening travel-limit stop (Fig.12 ref.2).
- 8) UNSCREW the travel-limit stop screw (Fig.12 ref. 2), until the leaf begins to move.
- 9) Fasten the supplied U-bracket (Fig.13) on the travel-limit stop screw.
- 10) Open and close the gate to check if the travel-limit stop is correctly adjusted.
- 11) Re-lock the operator again, following the instructions in chapter 4.1.

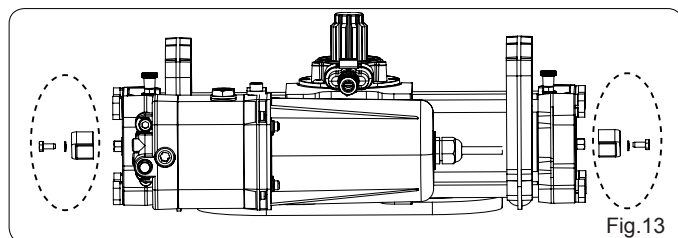

Fig.13

3.3 FINAL STEPS

- 1) Place the encoder in its slot on the motor (See Fig. 14).
- 2) Connect the motor (Fig.1 ref. 8) and the encoder (Fig.1 ref. 9) to the control unit, following the specific instructions.
- 3) Secure the cover of the load bearing box with the supplied screws (Fig.15;16).
- 4) Place the warning signs on both sides of the gate

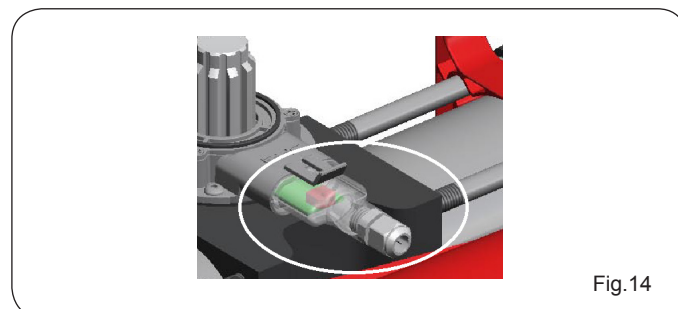

Fig.14

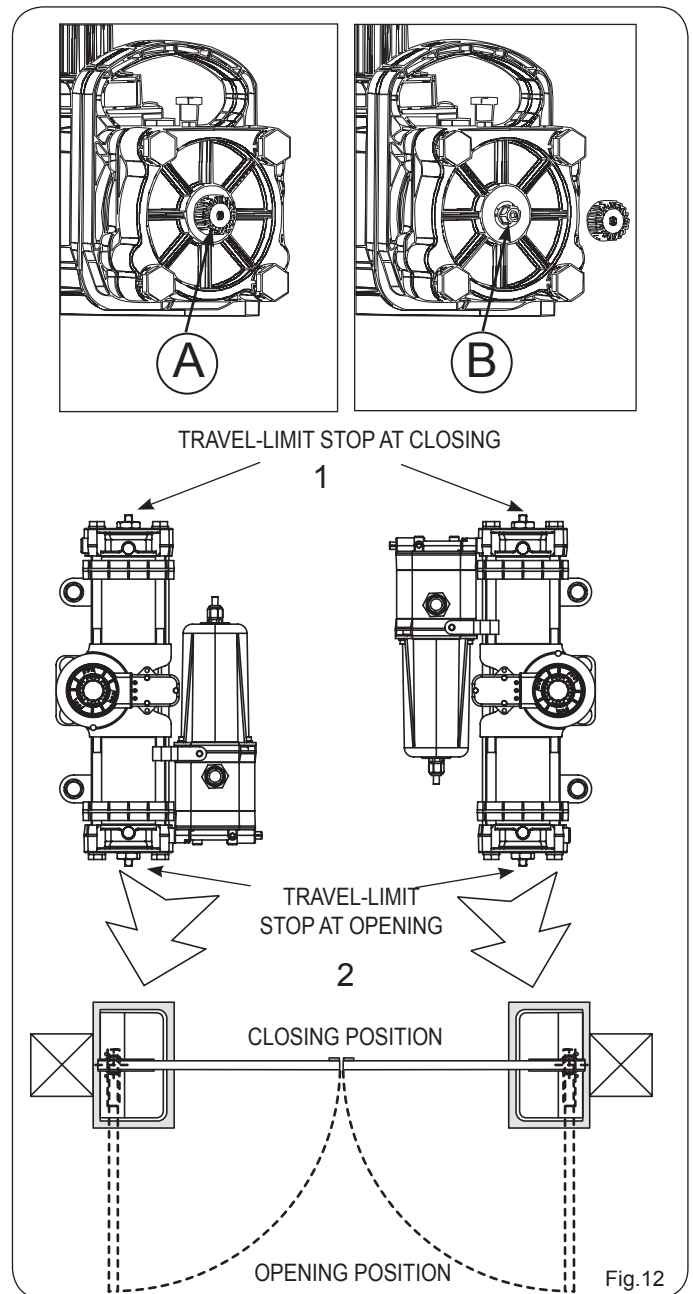

Fig.12

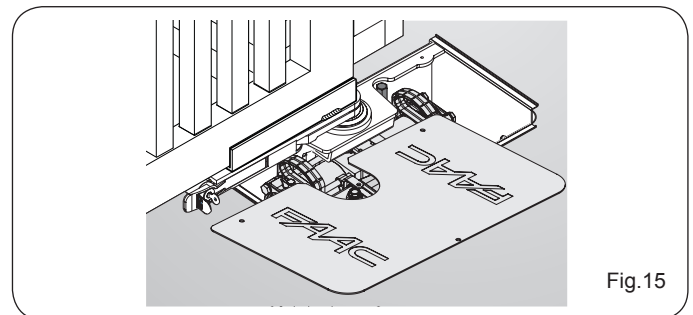

Fig.15

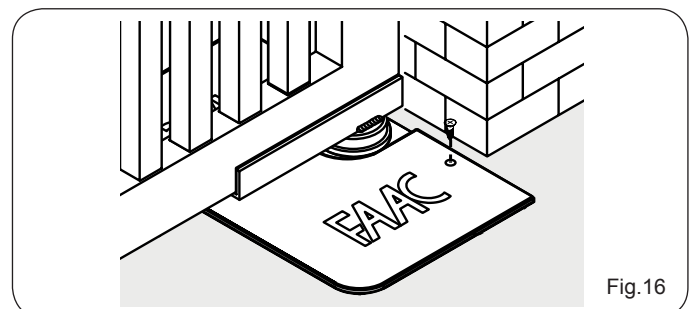

Fig.16

4. MANUAL OPERATION

⚠ MAKE SURE TO CUT POWER BEFORE RELEASING OR LOCKING THE OPERATOR

4.1 BUILT IN HYDRAULIC RELEASE

If the gate has to be moved manually due to a power cut or fault of the automated system, you can use the hydraulic release device with the release key (Fig.17):

- 1) Remove the cover from the bearing case.
- 2) Turn the release screw
 - To RELEASE, turn the screw counter-clockwise by one turn. (DO NOT COMPLETELY UNFASTEN THE SCREW TO AVOID SPILLING THE OIL.
 - To re-engage the hydraulic operation, turn the screw clockwise up to the mechanical stop point. (DO NOT OVERTIGHTEN)

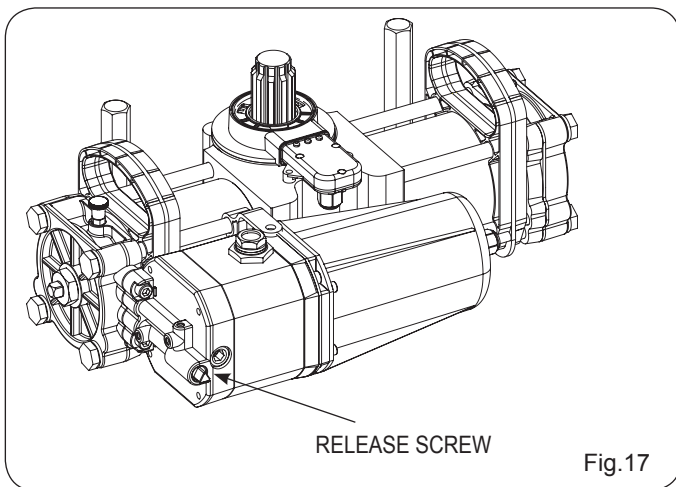

Fig.17

4.2 EXTERNAL HYDRAULIC RELEASE

The S800H operator kit comes with a field installable hydraulic manual release, that can be conveniently mounted on top of the load bearing box

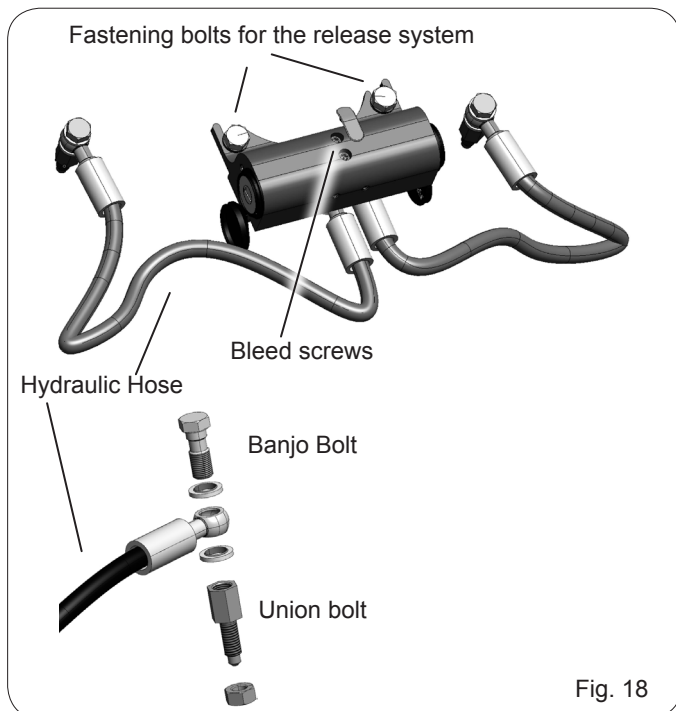

Fig. 18

4.2.1 INSTALLATION PROCEDURE

- 1) Release the operator using the built in hydraulic release
- 2) Fasten the external release body to the load bearing box system using the two supplied M8 screws (fig. 19 ref. 1)
- 3) Remove the bleed unions on the operator, then connect those supplied with the release system (Fig. 19 ref. 2)
- 3) Re-lock the built in manual release.

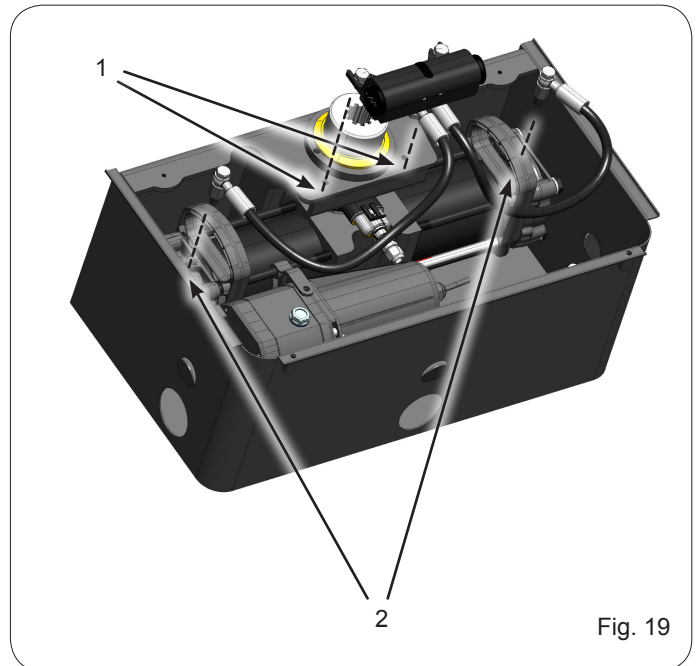

Fig. 19

4.2.2 BLEEDING PROCEDURE

The installation of the hydraulic release could have let air in the circuit, causing irregular operation like an incorrect movement of the leaf and excessive noise during operation. To solve this problem, operate as follows:

- 1) Command an opening movement of the gate.
- 2) During the leaf movement, loosen the opening bleed screw (Fig.20 ref.1)
- 3) Let air come out from the hydraulic circuit through the bleed screw until non-emulsified oil comes out.
- 4) Tighten the bleed screw before the operator ends the opening cycle.
- 5) Command a closing movement of the gate.
- 6) During the leaf movement, loosen the closing bleed screw (Fig.20 ref. 2)
- 7) Let air come out from the hydraulic circuit through the bleed screw until non-emulsified oil comes out.
- 8) Tighten the bleed screw before the operator ends the closing cycle.
- 9) Repeat the operations, if necessary.
- 10) Restore the oil level until it is just under the cap, using the oil supplied (Fig. 21 ref.1).

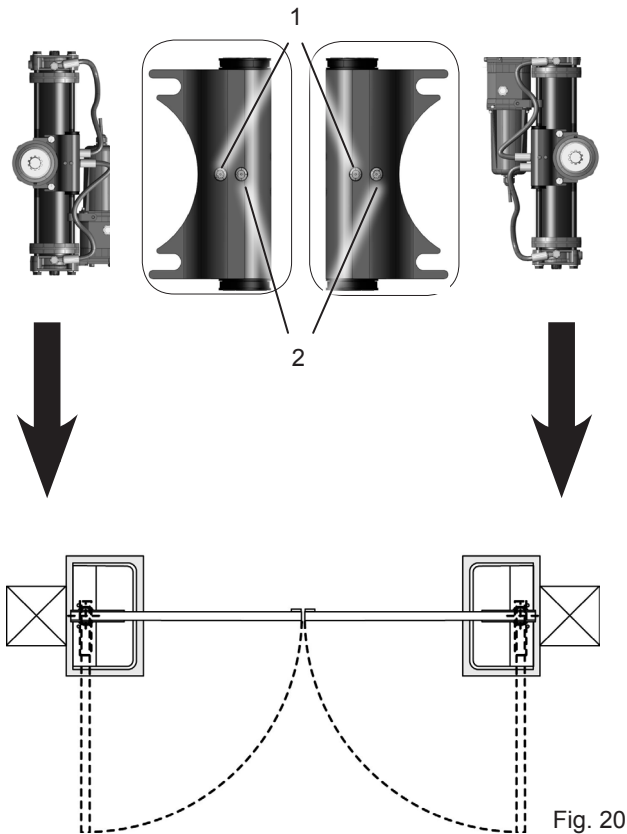

Fig. 20

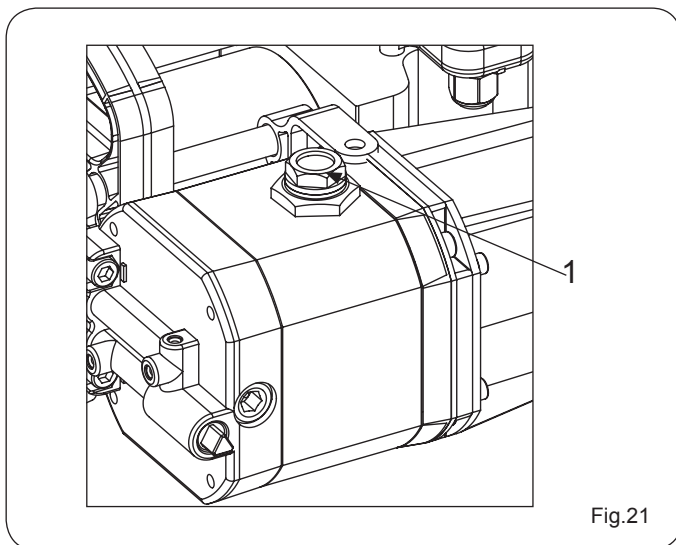

Fig.21

4.2.3 USING THE RELEASE SYSTEM

To release the operator, remove the plastic cover, insert the key and turn the release lock counter-clockwise for about one turn. (Fig. 22 ref. 1)

To lock the operator again, turn the release lock clockwise until reaching the stop point, do not force (Fig. 22 ref. 2)

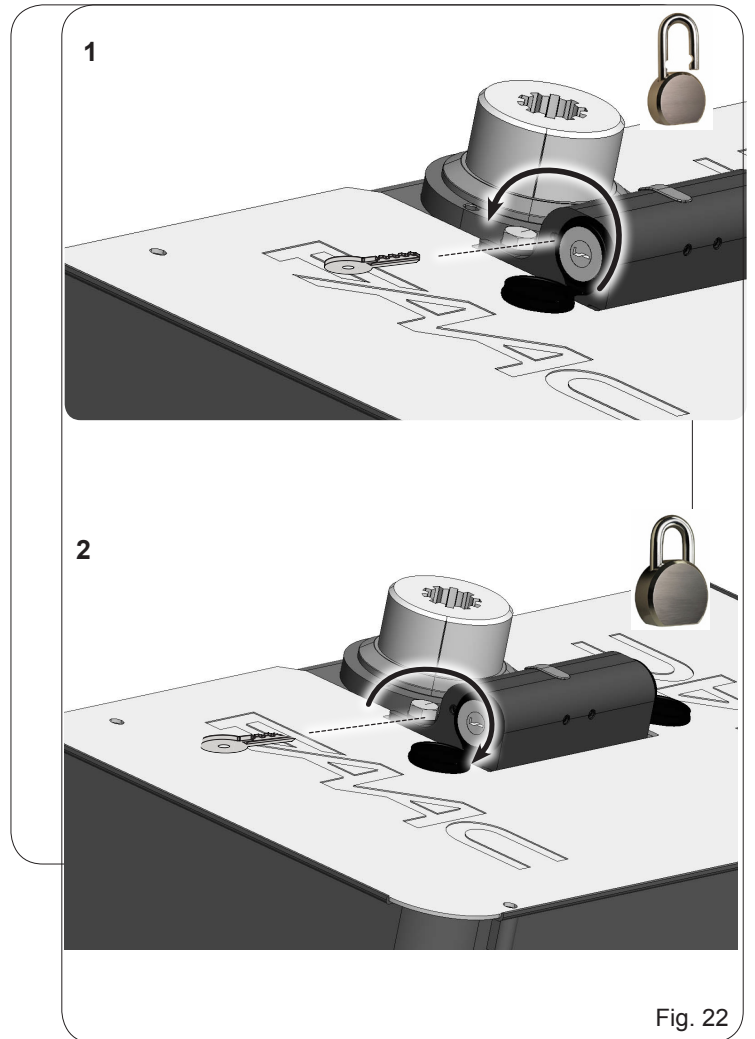



Fig. 22

5. MAINTENANCE

Run a functional check of the system at least every 6 months, with special attention to the efficiency of the safety and release devices (including the thrust force of the operator), and to the smooth operation of the gate hinges.

5.1 BLEEDING OPERATIONS

 THE S800H OPERATOR IS SUPPLIED WITH THE HYDRAULIC CIRCUIT ALREADY AIR FREE. DO NOT BLEED. BLEEDING IS ONLY NECESSARY IN THE EVENT OF MAINTENANCE OF THE HYDRAULIC SYSTEM, OR INSTALLATION OF THE HYDRAULIC MANUAL RELEASE

The presence of air in the hydraulic circuit causes the automated system to operate incorrectly, i.e. a faulty movement of the leaf and too much noise while operating. Please refer to the procedure illustrated in paragraph 4.2.2 to correct this problem:

6. ENCODER CONNECTION

The S800H operator comes with an encoder system that allows the control board to monitor the position of the leaf connected to the operator at any time. The proper assignment of the leaf to the corresponding encoder depends on the connection of the two encoder wires (leaf 1- encoder 1; leaf 2 - encoder 2).

To verify the proper assignment of **LEAF 1 - ENCODER 1 - MOTOR 1** and **LEAF 2 - ENCODER 2 - MOTOR 2**, you can use the LEDs visible through the encoder's shell, as shown in Figures 23 and 24:

To invert the leaf-encoder combination, change the encoder polarity by swapping its wires until the right LEDs are lit.

NOTE: THE ENCODER WIRES MUST BE CONNECTED TO THE BUS CONNECTOR OF THE CONTROL BOARD.

Please refer to the E024U board pinout for more information

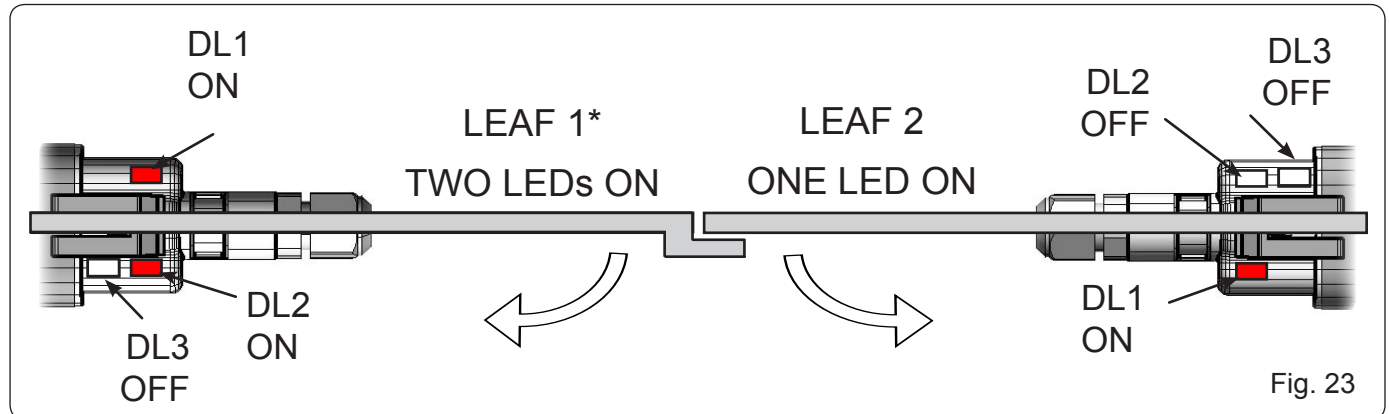

Fig. 23

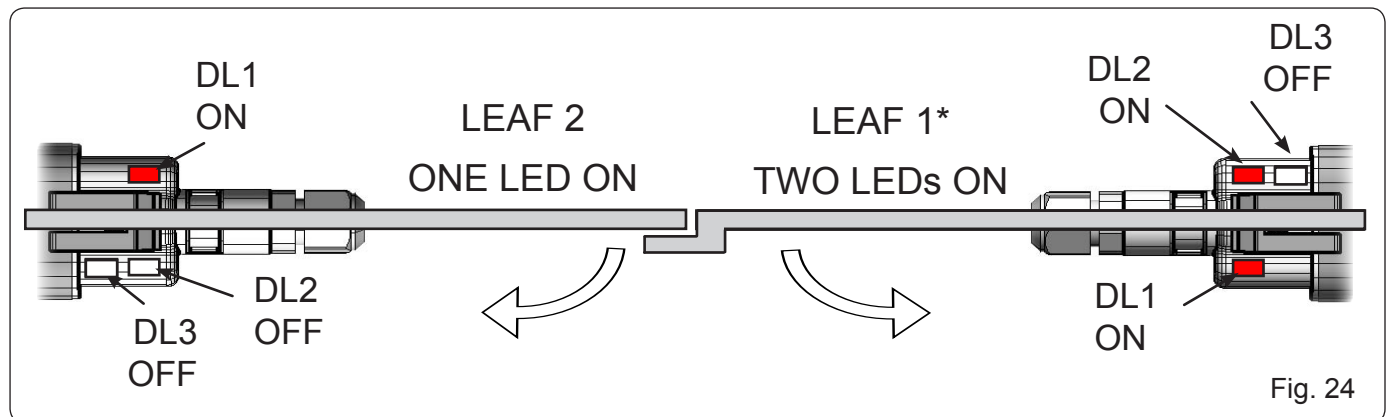

Fig. 24

Leaf 1 opens first and close second. if you do not have a leaf overlap between 1 and 2, the board may be set with leaf delay equal to zero

Switching the polarity of the encoder's wires on the board connector you can change the association of the encoder to the leaf.

TABLE 1

LED	ON STEADY	FLASHING	OFF
DL 1	Power ON and encoder communicating with the control board	Power ON but encoder NOT communicating with the board (eg: wiring error, both encoders with the same polarity)	Power OFF and no communication (eg: no power or no connection)
DL 2	Encoder assigned to Leaf 1	/	Encoder assigned to Leaf 2
DL 3	/	Encoder generating pulses during leaf movement	Leaf not moving

7. S800H PARTS DIAGRAM

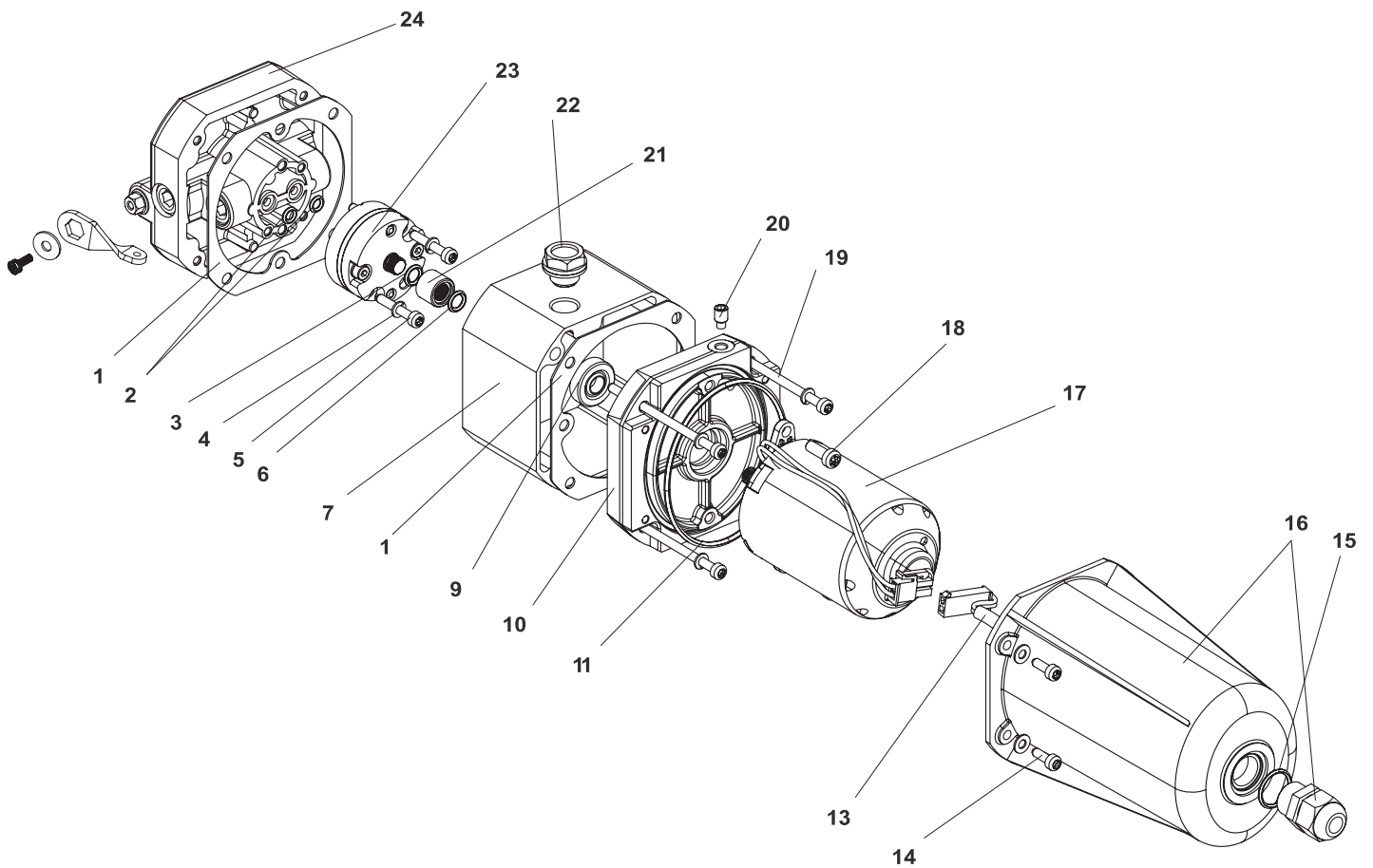

1	63000276	GASKET FOR TANK
2	7090010015	SEAL OR 4.48X1.78
3	7090030015	GASKET OR 6.75X1.78
4	703101	WASHER GROWER 4 1751 Z
5	701632	SCREW TCEI M4x25 UNI 5931 8G Z
6	7090030015	GASKET OR 6.75X1.78
7	63000266	24 V HYDR. UNIT TANK
9	63000306	N7MMR TYPE GASKET
10	63000376	S800H MOTOR FLANGE
11	7090100025	GASKET OR 72.69X2.62
13	63001665	S800H UL MOTOR CABLE
14	701103	TCEI 4X 12 5931 INOX
15	7090190015	GASKET OR 14.00X1.78
16	63002635	S800H MOTOR COVER
17	63000376	S800H MOTOR
18	701072	SCREW TCEI 5X 14 5931 8.8 Z
19	701975	SCREW TCEI M4x75 UNI 5931 INOX
20	701245	STEI M6x8 UNI 5925 + VEBLOCK 360°
21	63000256	BUSH FOR PUMP SHAFT
22	7110015	CAP
23	63000246	0.5 LT 10010 PUMP
24	63000226	CB FLANGE

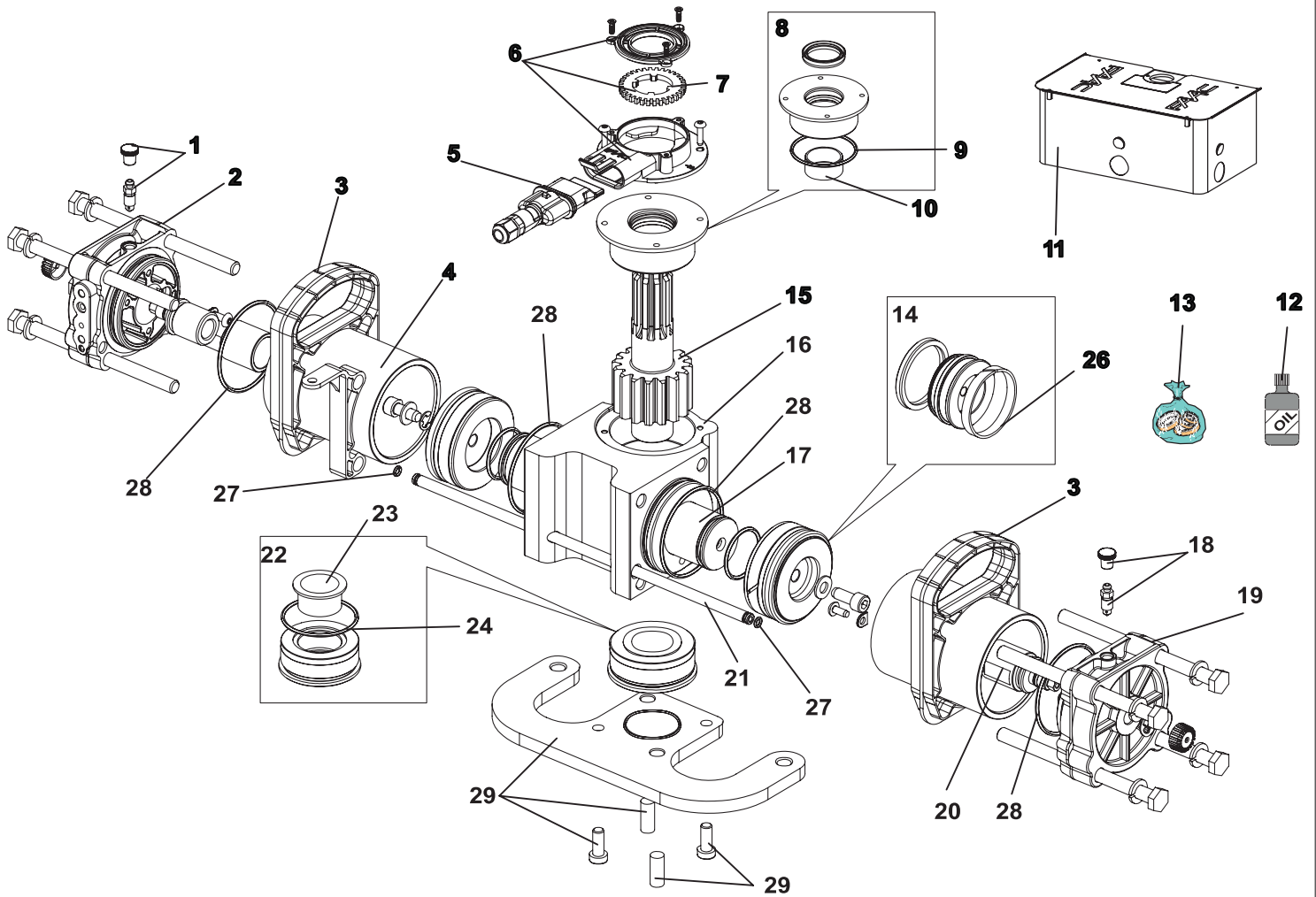

1	63000016	ESCAPE VALVE GROUP
2	63000136	FLANGE LH
3	63002625	NR. 2 HANDLES
4	63000116	100° CYLINDER BARREL
5	63000125	ENCODER
6	63000005	ENCODER SUPPORT KIT
7	63000115	MAGNETIC DISC
8	63000076	UPPER BUSHING GROUP
9	63000176	OR 55.25x2.62 GASKET
10	63000186	IGUS CYLINDRICAL BUSH
11	490112	FOUNDATION BOX
12	714017	HYDRAULIC OIL LT. 1
13	63000006	GASKET KIT
14	63000106	PISTON
15	63000056	PISTON SHAFT
16	63000046	CENTRAL BODY
17	63000086	100° RACK
18	63000016	ESCAPE VALVE GROUP

19	63000146	FLANGE RH
20	63000036	POSITIVE STOP
21	63000156	100° FEEDING PIPE RH
22	63000066	LOWER BUSHING GROUP
23	63000206	IGUS CYLINDRICAL BUSH
24	63000196	OR3200 50.47x2.62 GASKET
26	7092025	BALS B275236 GASKET
27	7090635	SEAL ORM 5x1.5 (0050-15)
28	7090490025	GASKET OR 64.77X2.62
29	63002465	FOUNDATION PLATE

1. E024U CONTROL BOARD DESCRIPTION & CHARACTERISTICS

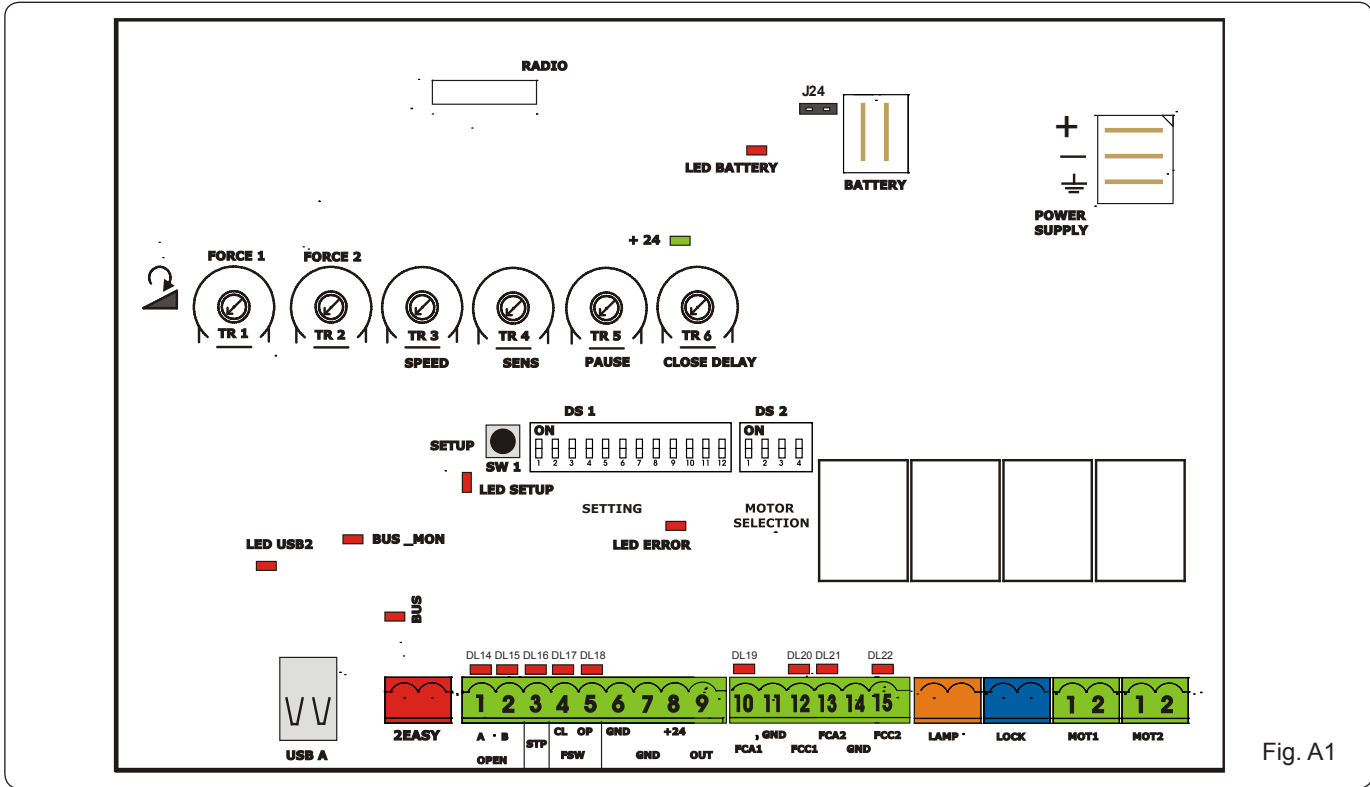

Fig. A1

1.1 TECHNICAL SPECIFICATIONS

Main power supply	115/230 V~ 50/60 Hz switchable
Secondary power supply	24 Vdc - 16 A max. (min. 20 Vdc. - max. 36 Vdc.)
Power consumption	stand-by = 4W max. = 400 W
Max load per motor	7 A
Accessory power supply	24 Vdc - 500 mA
Battery charge current	150 mA
Operating temperature	-4 °F.....+131 °F
Protection fuses	All self-resetting
Main power fuse	2.5 A Timed
Operating Logics	E, A, S, EP, AP, SP, B, C
Operating time out	10 min.
Pause time	Programmable (0 to 4 min) with trimmer
Motor force, speed, obstacle sensitivity, closing delay	Programmable with dedicated trimmer
Connector inputs	Power supply, Battery, Radio receiver, USB
Terminal strip inputs	Encoder, Open A, OpenB, Stop, Open safety fotocell, Closing safety fotocell, Limit switches
Terminal strip outputs	Lamp, Buzzer, Motors, Lock, Programmable OUT, accessory power supply
Programming	With trimmers, dipswitches and pushbutton

1.2 LAYOUT AND COMPONENTS

RADIO	Connector for the radio receiver
BATTERY	Connector for the backup battery
J24	Jumper to disable battery charging (With the jumper present the battery is charged)
POWER SUPPLY	DC Power supply input
TR1 to TR6	Programming Trimmers
+24 LED	DC power indicator
SW1 - SETUP	Pushbutton for automatic setup
DS1 - DS2	Programming dipswitches
LED ERROR	Troubleshooting indicator
USB A	USB connection for software upgrade

1.3 RADIO CONNECTION

On the radio connector it's possible to plug in receivers RP and RP2. With a single channel radio RP it will be possible to activate only the OPEN A input, with a dual channel radio RP2 it will be possible to activate both OPEN A and OPEN B inputs. Plug in the radio board with the component side towards the internal part of the board.



Make sure you insert or disconnect the board ONLY with the power off.

2. INPUT / OUTPUT DESCRIPTION

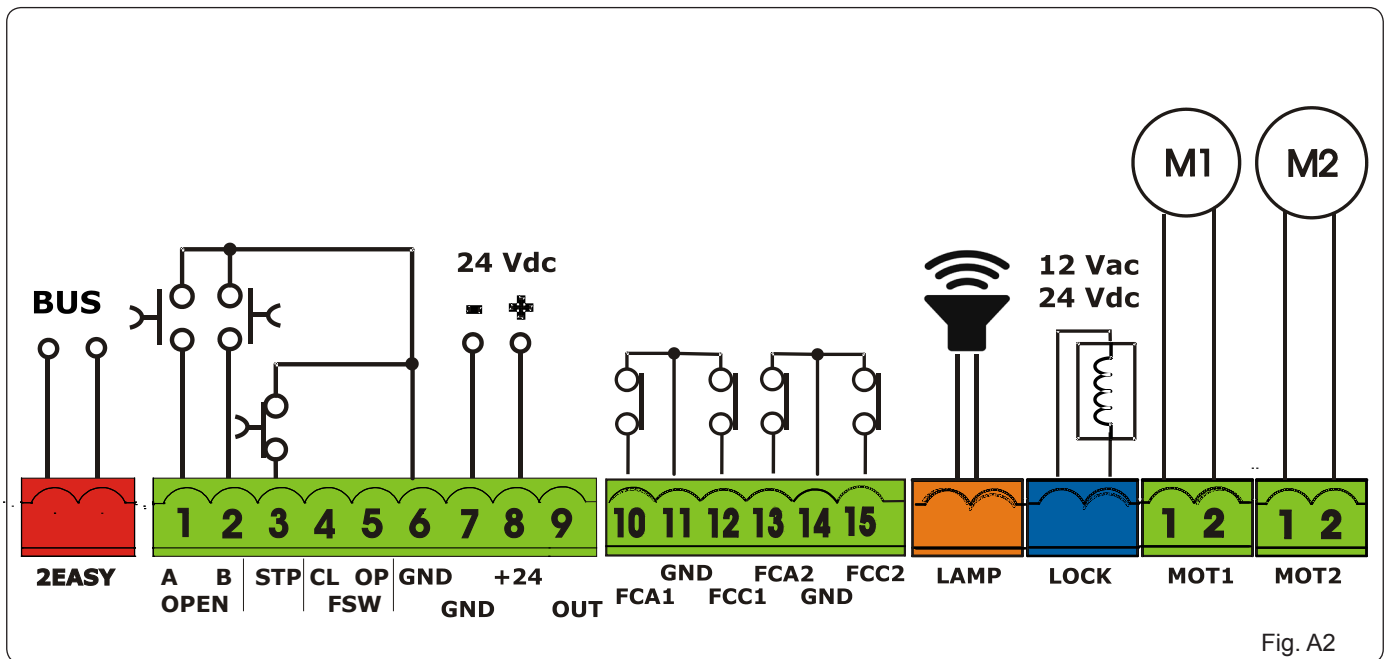

Fig. A2

PIN	LABEL	FUNCTION
2 EASY	2 EASY	Input for bus 2easy accessories (encoder)
1	OPEN A	N.O. Contact for total opening command
2	OPEN B / CLOSE	OPEN B: N.O. Contact for opening of leaf 1 only (with only one leaf the opening stops at 50% of traveling) CLOSE (LOGIC B-C): N.O. Contact for closing command
3	STOP	N.C. Contact for stop command
4	FSW CL	N.C. Contact for closing safety
5	FSW OP	N.C. Contact for opening safety
6	GND (-)	24 Vdc negative
7	GND (-)	24 Vdc negative
8	+ 24	24 Vdc positive
9	OUT (-)	Programmable output (See: DS1 SW 11-12)
10	FCA 1	Open limit switch Motor 1
11	GND (-)	24 Vdc negative
12	FCC 1	Close limit switch Motor 1
13	FCA 2	Open limit switch Motor 2
14	GND (-)	24 Vdc negative
15	FCC2	Close limit switch Motor 2
LAMP	LAMP	Audio alarm output (DS1 SW11=OFF) Output for flashing light 24Vdc 15W max (DS1 SW11=ON)
LOCK	LOCK	Output for electrical lock, max 5A pulse (DS2 - SW 4=OFF) 12 Vac / 24Vdc Always ON (maglock): max 1 A (DS2 - SW 4=ON) 24 Vdc
MOT1	MOT 1	Motor 1 output (first moving motor)
MOT2	MOT 2	Motor 2 output (second moving motor)
USB A	USB	Firmware upgrade input

3. PHOTOCELLS CONNECTIONS

How to connect Normally Open contacts.
(Connect them in parallel)

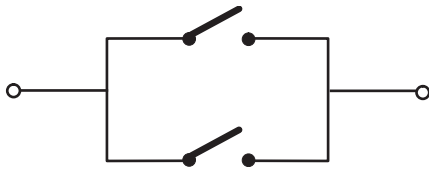

Fig. A3

How to connect Normally Close contacts.
(Connect them in series)



Fig. A4

The E024U board allows the connection of several safety devices (for example photocells). With photocells you can activate the FAILSAFE function, which, before each movement of the operator, tests each fotocells. In case the test fails the movement is inhibited. To activate this function set to ON the dip-switch N. 11 and 12 of DS1, and connect the negative of the transmitter to the OUT pin (No.9).

The photocells must be connected depending on which area they must protect. (See Fig. A5)

Closing Safety D : These photocells protect the area covered by the gate during the closing movement. They have no effect during the opening movement.

Opening Safety B-C : These photocells protect the area covered by the gate during the opening movement. They have no effect during the closing movement.

Opening/Closing Safety A : These photocells protect the area covered by the gate both during the opening and the closing movements.

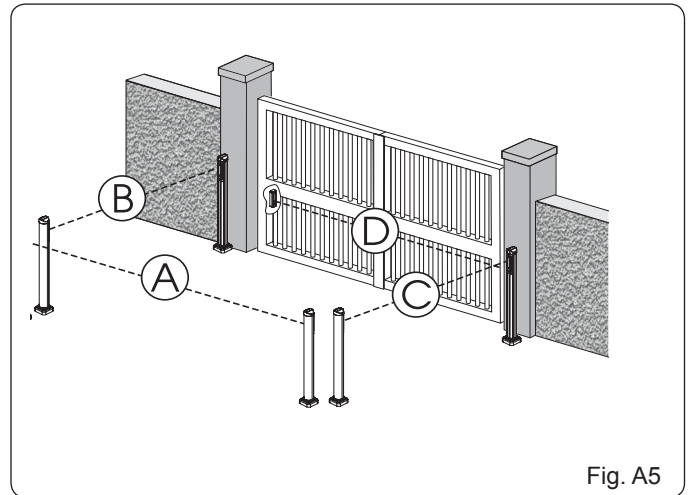

Fig. A5

3.1 CONNECTIONS TO NORMALLY CLOSE (N.C.) PHOTOCELLS

Connection of a pair of closing photocells and a pair of opening/closing photocells

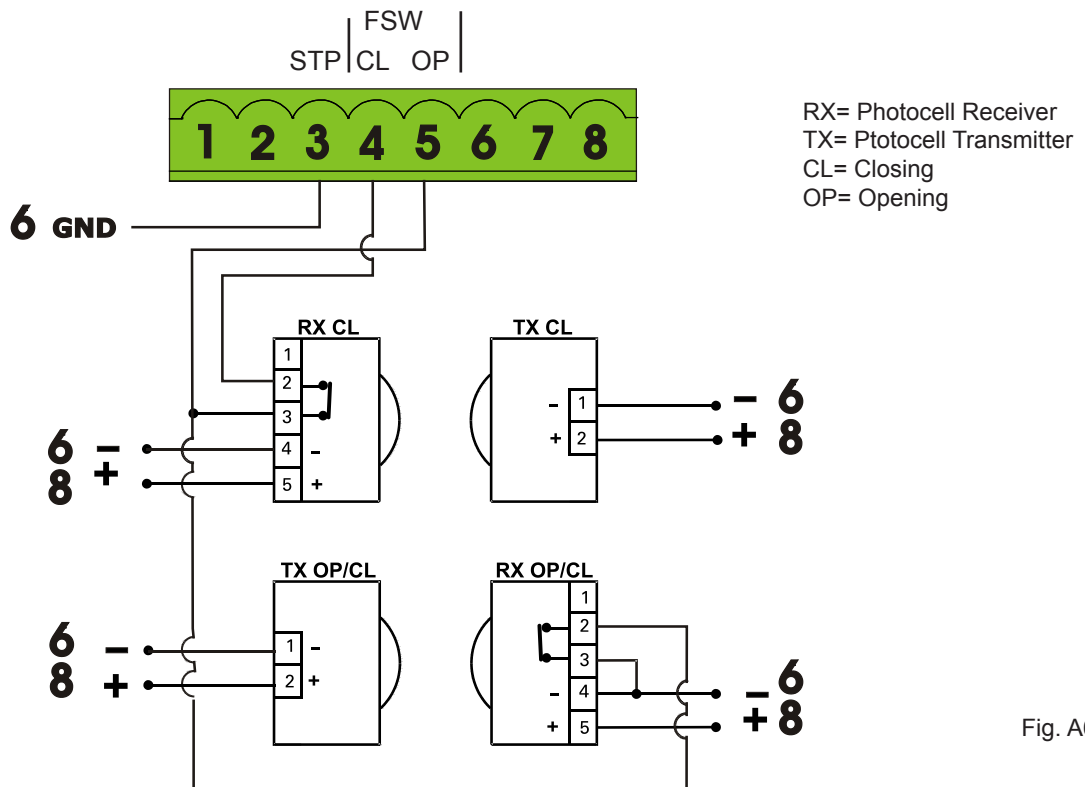
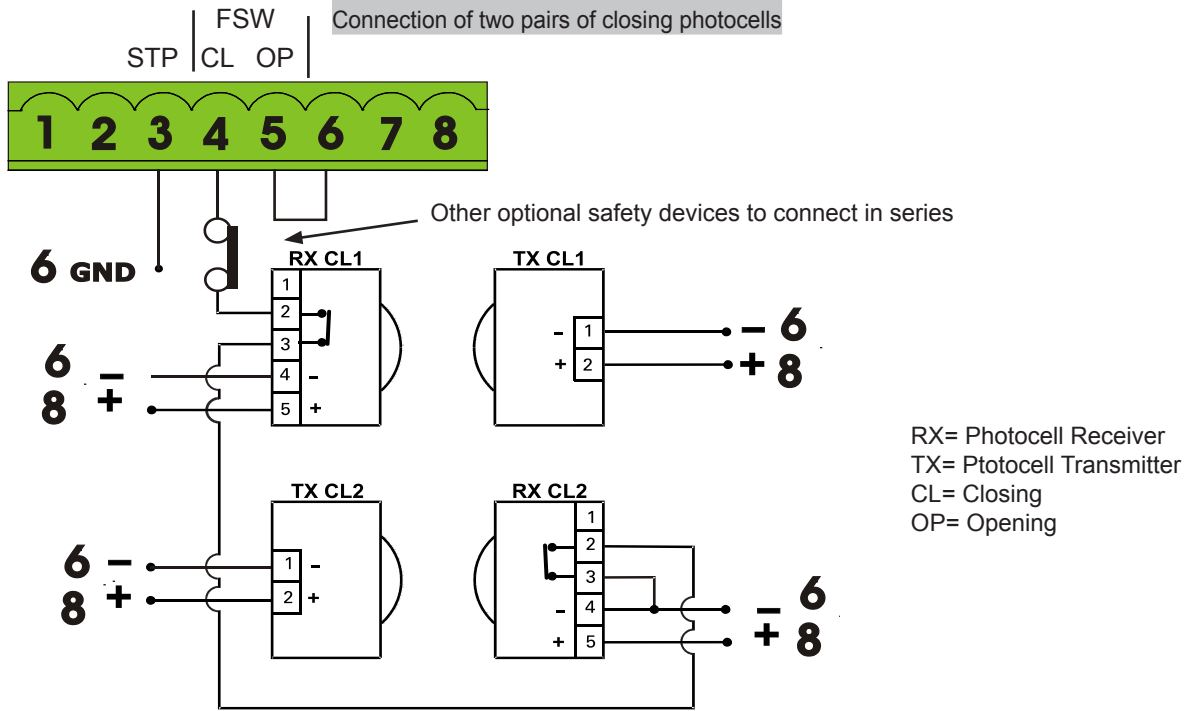

Fig. A6

To use the FAIL-SAFE mode connect the negative power supply of the transmitters to OUT (pin 9), and set dip-switch 11 and 12 to ON on DS1



To use the FAIL-SAFE mode connect the negative power supply of the transmitters to OUT (pin 9), and set dip-switch 11 and 12 to ON on DS1

When using the FAIL-SAFE mode also the safety inputs not used (FSW CL , FSW OP) must be connected to OUT (pin No. 9)

Fig. A7

Connection of a pair of closing photocells, a pair of opening photocells and a pair of opening/closing photocells

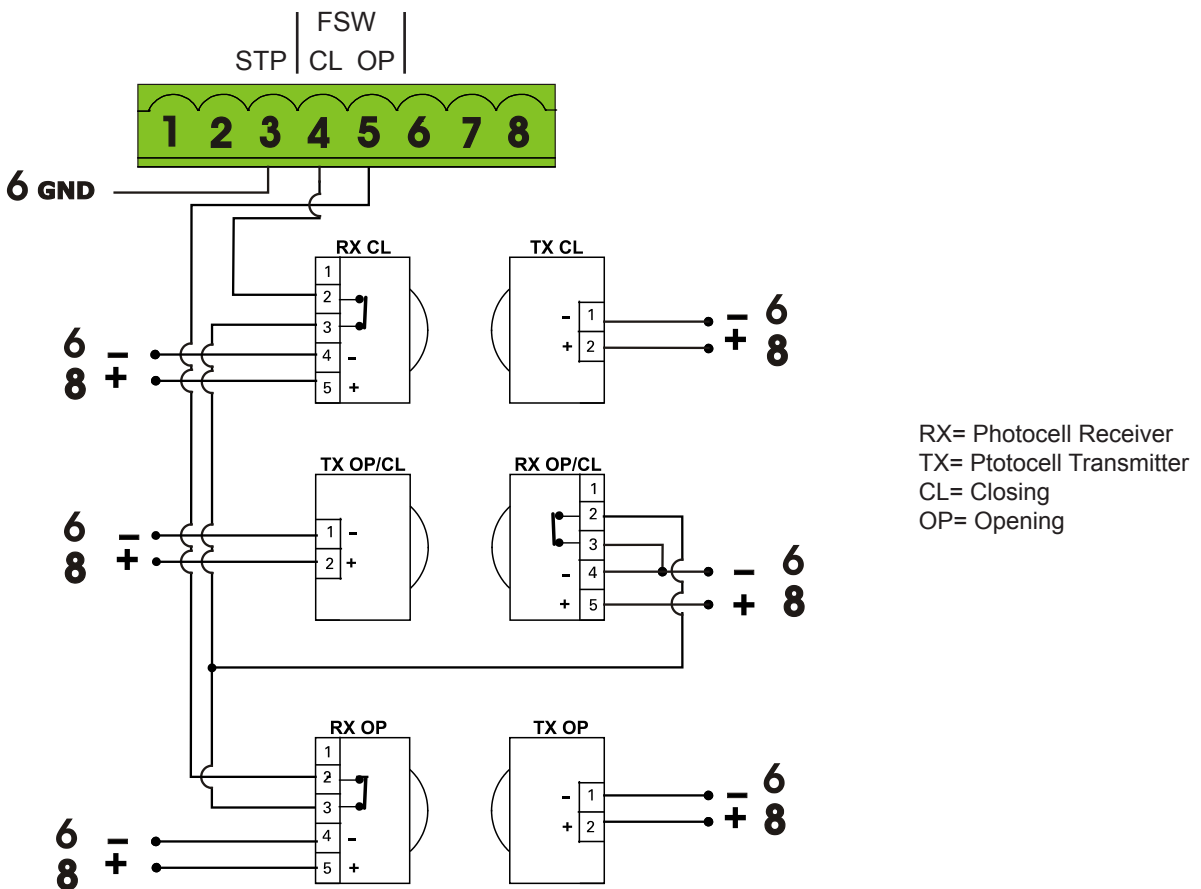

To use the FAIL-SAFE mode connect the negative power supply of the transmitters to OUT (pin 9), and set dip-switch 11 and 12 to ON on DS1

Fig. A8

Connection of a pair of closing photocells and a pair of opening photocells

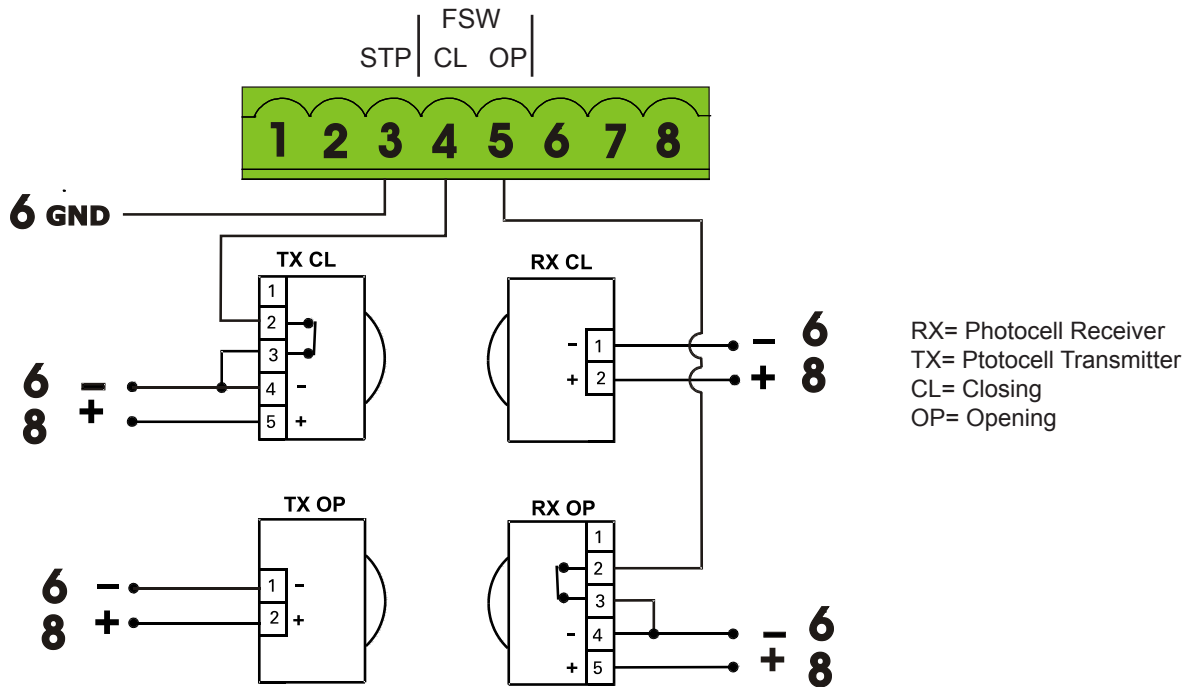

☞ To use the FAIL-SAFE mode connect the negative power supply of the transmitters to OUT (pin 9), and set dip-switch 11 and 12 to ON on DS1

Fig. A9

Connection of no safety or stop devices
(NOT RECOMMENDED)

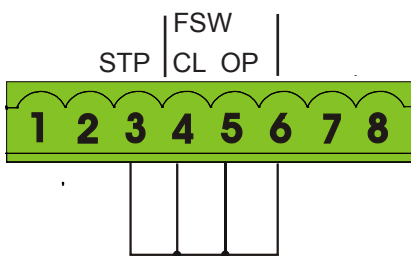

Fig. A10

Connection of a generic closing safety device and a generic open safety device

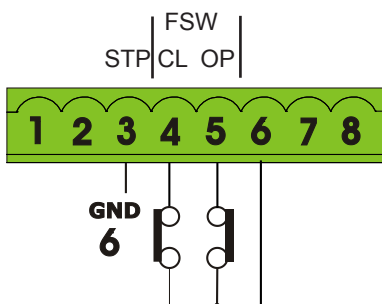
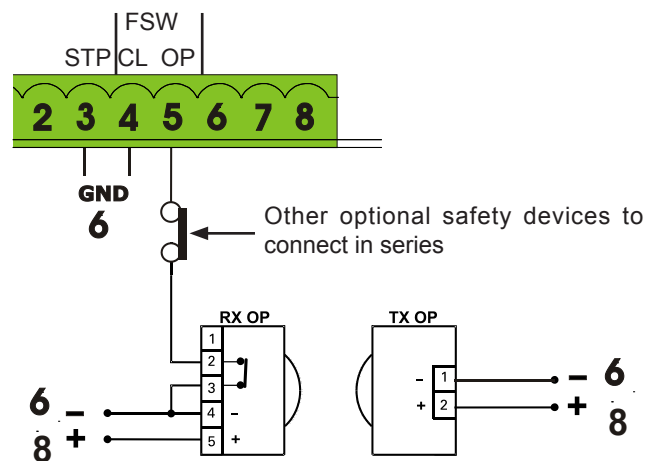

Fig. A11

Connection of one pair of opening photocells



☞ To use the FAIL-SAFE mode connect the negative power supply of the transmitters to OUT (pin 9), and set dip-switch 11 and 12 to ON on DS1

☞ When using the FAIL-SAFE mode also the safety inputs not used (FSW CL, FSW OP) must be connected to OUT (pin No. 9)

Fig. A12

4. PROGRAMMING

4.1 DIP SWITCH DS1 SETTINGS FOR OPERATING LOGIC

OPERATING LOGIC

DS 1: SW 1 - SW 2 - SW 3



LOGIC	SW 1	SW 2	SW 3	PAUSE TIME	DESCRIPTION
E (default) Semiautomatic	OFF	OFF	OFF	NO	One command opens, the next one closes. A command during opening stops the gate
A Automatic	ON	ON	ON	0 - 4 min	One command opens, waits for the pause time and then closes automatically
S Security	OFF	OFF	ON	0-4 min	One command opens, waits for the pause time and then closes automatically. If the closing safety is activated or another command is given during the pause time it closes
EP Semiautomatic step by step	OFF	ON	OFF	NO	One command opens, the next one closes. During the movement a command stops the gate
AP Automatic step by step	OFF	ON	ON	0-4 min	One command opens, waits for the pause time and then closes automatically. A command during the pause time holds the gate open
SP Security step by step	ON	OFF	OFF	0-4 min	One command opens, waits for the pause time and then closes automatically. If the closing safety is activated during pause time the gate closes in 5 s. A command during pause time holds open the gate
B Manned Pulsed	ON	OFF	ON	NO	An open A command opens the gate, an open B command closes the gate
C Manned Constant	ON	ON	OFF	NO	Holding open A active opens the gate, holding Open B active closes the gate



For more details on the operating logics please refer to Chapter 12 - Function Logics

4.2 ADJUSTING TRIMMERS

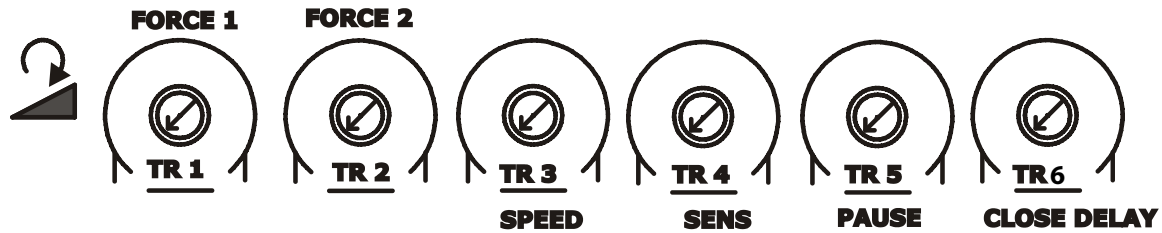
**TR1 – FORCE ADJUSTMENT MOTOR 1**

Turn clockwise to increase the opening and closing force

TR 2 – FORCE ADJUSTMENT MOTOR 2

Turn clockwise to increase the opening and closing force

TR 3 – SPEED ADJUSTMENT FOR MOTOR1 AND MOTOR 2

Turn clockwise to increase the opening and closing speed

TR 4 – SENSITIVITY ADJUSTMENT FOR OBSTACLE DETECTION FOR MOTOR 1 AND MOTOR 2

Turn clockwise to increase the sensitivity for obstacle detection.

With this trimmer you can adjust the reaction time for the board to invert the motion of the gate in case of obstacle detection, or the complete stop in case the board is in the positive stop detection zone.

If an obstacle is detected during the gate movement the board will invert the motor rotation until the gate goes back to the original starting position. If in the successive movement an obstacle is detected again the board will be put in alarm mode and won't take any more commands until the STOP input is activated (Alarm Reset) or power is cycled

TR 5 – PAUSE TIME ADJUSTMENT (0 - 4 min.)

Turn clockwise to increase the pause time.

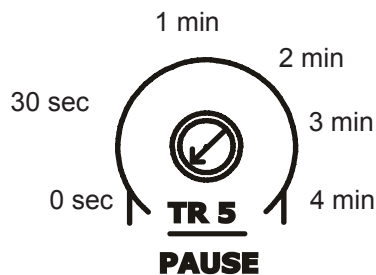

 Dip switches DS1: 1 to 3 need to be set for an operating mode with PAUSE time for this adjustment to have any effect

TR6 - CLOSING DELAY OF LEAF 1 OVER LEAF 2 ADJUSTMENT (0 - 15 sec)

Turn clockwise to increase the delay

4.3 DIP SWITCH DS1 SETTINGS FOR BOARD SETUP

BOARD SETUP		DS 1: SW 4 to SW 12	
OPENING DELAY	SW 4		
0 sec (default)	OFF	The opening of leaf 2 is delayed after the opening of leaf 1. This is to avoid that the gate's leaves interfere with each other during the initial part of the movement. In case there is only one leaf it has no effect.	
2 sec	ON		
REVERSE AND LAST STROKE	SW 5	If active, before opening, while the gate is closed, the motors thrust to close for 2 s to facilitate the release of the electric lock. At closing the motors are activated for a final stroke after slowdown to facilitate locking of the electric lock.	
inactive (default)	OFF		
active	ON		
MAX THRUST AT STARTUP	SW 6	With this function active the motors work at maximum force at startup (regardless of the force setting) during the initial phase of the movement. Useful for heavy leaves	
inactive (default)	OFF		
active for 3 sec	ON		
AUTOMATIC OPENING IN CASE OF POWER FAILURE	SW 7	If active and with the optional backup battery installed, the board will open the gate after one minute from the power failure and keep it open. Within the minute wait it's always possible to open and close the gate with a command. If the logic used has a pause time the board will close the gate when the power comes back.	
inactive (default)	OFF		
active	ON		
CLOSING SAFETY LOGIC	SW 8	With this function you can choose the behaviour of the closing safety. With SW8 OFF the gate movement will be reversed as soon as the safety is active, with SW8 ON the gate will stop when the safety is active and it will reverse only when the safety is deactivated again.	
immediate reverse (default)	OFF		
reverse when cleared	ON		
PREFLASHING	SW 9	This function activates the flashing lamp for 5s before the movement of the gate	
inactive (default)	OFF		
active for 5 sec	ON		
EXTRA SENSITIVITY TO OBSTACLE DETECTION	SW 10	If active this function allows to have an immediate reverse in case the gate hits a rigid obstacle, while keeping the motor active in case of a gradual increment of resistance, like with wind pressure on the gate or increased friction	
inactive (default)	OFF		
active	ON		
ORANGE TERMINAL FUNCTION	SW 11	If OFF after the second consecutive obstacle detection this output is activated until the STOP contact is open or the power is cycled if ON the output can be connected to a warning lamp. NOTE: for UL325 compliance this switch must be left OFF	
Audio Alarm (default)	OFF		
Warning Lamp	ON		
OUT FUNCTION (pin 9) max 100mA	SW 12	if OFF: use pin 9 as power supply negative for a warning lamp. The lamp will be active during opening, pause and stop. Flashing during close, off when the gate is closed If ON: use pin 9 as power supply negative for the safety photocells. Before any movement the board will check for the presence of the safety photocells. If the test fails the gate will not move.	
Lamp	OFF		
Photocells FAIL SAFE active	ON		

4.4 DIP SWITCH DS2 SETTINGS FOR OPERATOR TYPE AND LOCK MODE

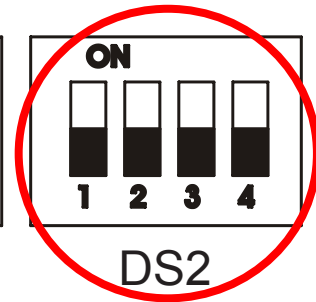
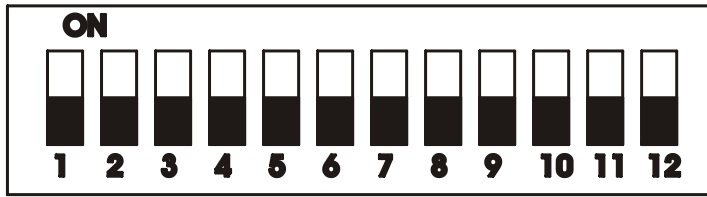

IMPORTANT



DS 2			
OPERATOR SELECTION			
OPERATOR TYPE	SW 1	SW 2	SW 3
S450H, S800H	OFF	OFF	OFF
S418	OFF	OFF	ON
415, 390, 770	ON	OFF	OFF

DS 2	
LOCK OUTPUT MODE	
OUTPUT MODE	SW 4
Active only for 3 sec. after an open impulse (from gate closed)	OFF
Active always except 3 sec. before an opening	ON

5. LED DIAGNOSTICS

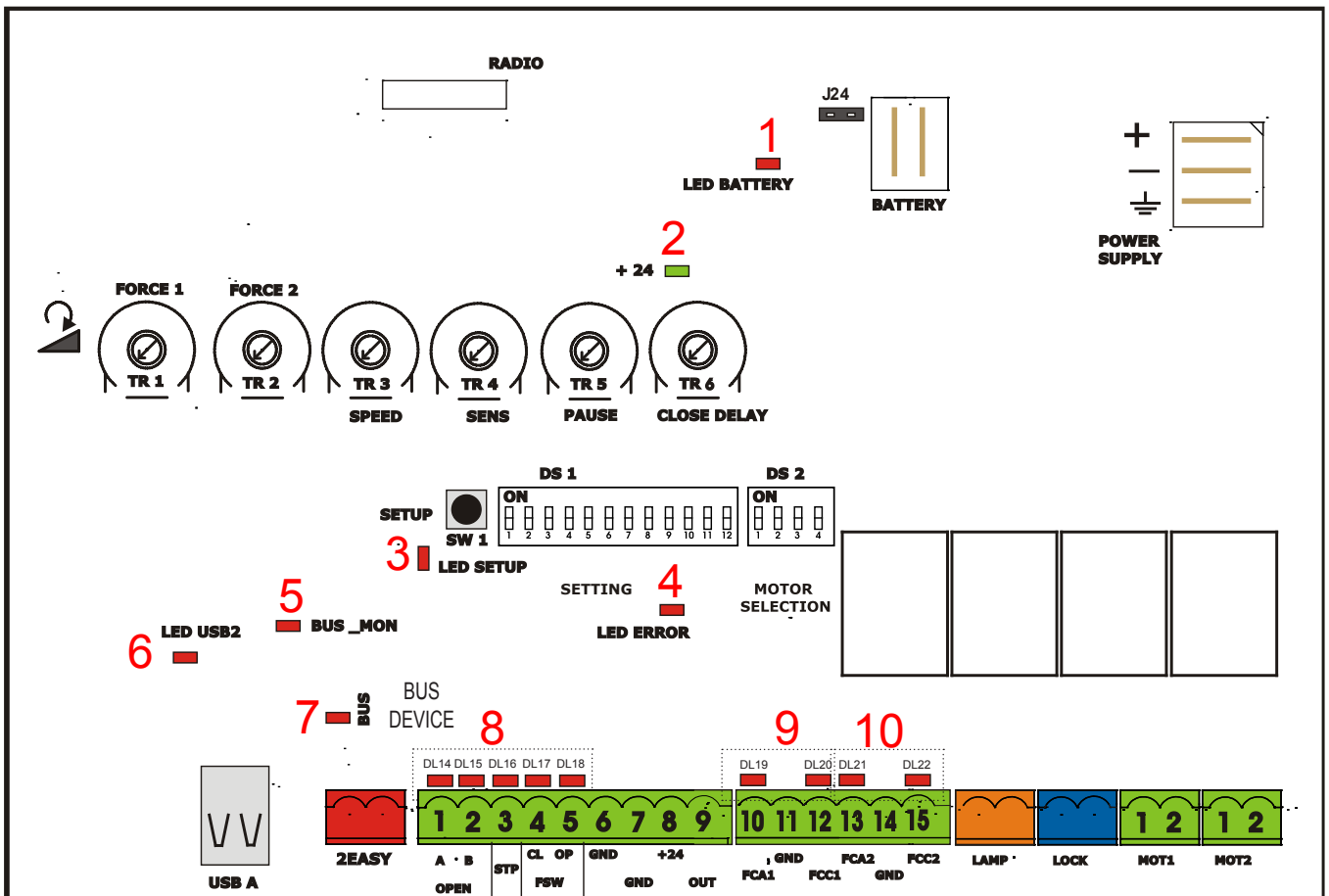

L E D	DESCRIPTION	LED STATUS		
		In BOLD the normal state with gate closed and working		
		ON STEADY	OFF	BLINKING
1	LED BATTERY	Board working on AC power	Board working on battery power or ext supply	Battery charging
2	LED +24	Main power present	Main power OFF	
3	LED SET-UP		Normal operation	SLOW BLINK (1 sec. ON - 1 sec. OFF) SET-UP needed
				FAST BLINK (0.5 sec. ON - 0.5 sec OFF) SET UP in in progress
4	LED ERROR	Board malfunction	No errors	Error conditions. See LED ERROR DISPLAY table
5	LED BUS_MON	Communication on Bus "2easy" OK	Communication bus "2Easy" inactive. Verify the bus "2Easy" devices for shorts	Bus 2Easy devices with the Same address. Verify dip switch Setting on photocells or Encoder LEDs
6	LED USB		Software update done or USB key not present	USB key inserted and software Update in progress (DON'T Remove the USB key)
7	RESERVED			
8	LED DL 14 OPEN A INPUT (N.O.)	OPEN A active	OPEN A not active	
	LED DL 15 OPEN B INPUT (N.O.)	OPEN B active	OPEN B not active	
	LED DL 16 STOP INPUT (N.C.)	STOP non active	STOP active or wiring error	
	LED DL 17 FSW CL INPUT (N.C.)	Closing safety devices clear	Closing safety devices triggered or wiring error	
	LED DL 18 FSW OP INPUT (N.C.)	Opening safety devices clear	Opening safety devices triggered or wiring error	
9	LED DL 19 FCA1 OPEN LIMIT SWITCH MOTOR1 (N.C.)	Limit switch OFF or not used	Limit Switch activated	
	LED DL 20 FCC1 CLOSE LIMIT SWITCH MOTOR1 (N.C.)	Limit switch OFF or not used	Limit Switch activated	
10	LED DL 21 FCA2 OPEN LIMIT SWITCH MOTOR2 (N.C.)	Limit switch OFF or not used	Limit Switch activated	
	LED DL 22 FCC2 CLOSE LIMIT SWITCH MOTOR2 (N.C.)	Limit switch OFF or not used	Limit Switch activated	



The diagnostic LED shows only one error condition at a time, with the priority of the below table. In case there is more than one error once one is eliminated the LED will show the next

LED ERROR DISPLAY		
NUMBER OF FLASHES	ERROR CONDITION	SOLUTION
1	OBSTACLE DETECTION	Remove the obstacle
2	BOARD IN SLEEP MODE (Slow blinking means that the automatic open in case of power failure function is active)	Verify the presence of AC power
3	MOTOR 1 FAILURE	Replace motor 1
4	MOTOR 2 FAILURE	Replace motor 2
5	ENCODER on motor 1 or motor 2 broken or wiring error	Verify the encoder wiring and LED status. If they are correct replace the encoder
6	FAIL SAFE FAILED	Verify the photocells wiring and alignment
7	BOARD THERMAL PROTECTION ACTIVE	Turn off the board and wait until the components cool down
8	MAX RUN TIME REACHED WITHOUT FINDING THE POSITIVE STOP (10 min.)	- Verify that the operator manual release is not engaged - Verify that the board recognizes the mechanical stop, in case redo the setup procedure

6. TIME LEARNING (SET-UP)

After powering up the board for the first time or when the board will need it the setup LED will blink at a slow frequency to indicate that the setup procedure to learn the running times is needed.

The setup can be redone at any time by pressing and holding the setup button as indicated below.

After the setup first movement, if the leafs are opening instead of closing you need to reverse the wires going to the motor that moves in the wrong direction

- When they reach the close mechanical stop or FCC1 and FCC2 both leafs stop and leaf 1 restarts automatically opening at full speed followed by leaf 2 (if present).
- If you selected an automatic logic the board will wait for the pause time and then closes the gate automatically. Otherwise you have to give an OPEN command to close the gate.

6.1 AUTOMATIC TIME LEARNING

WARNING: If the time learning setup is done automatically then the slow down points are set by the board on his own

Move the leafs to the mid position
Very important for a good result

- Press and hold the SETUP button until the SETUP LED lights up, wait about 3 sec. until it turns off and then release it immediately. NOTE: If you wait too long to release it the manual set-up will start. The LED will blink during the setup procedure
- Leaf 2 (if present) starts to move slowly in closing direction, stopping when it reaches the mechanical stop or FCC2.
- Leaf 1 begins to move slowly in closing direction, stopping when it reaches the mechanical stop, or FCC1.
- Leaf 1 starts to move slowly in opening direction, followed by leaf 2 (if present) still slowly.
- When they both reach the open mechanical stop or FCA1 and FCA2 they stop and reverse, leaf 2 (if present) automatically starts closing at full speed followed by leaf 1.

6.2 MANUAL TIME LEARNING

WARNING: If the manual time learning setup is done then the slow down points must be set by the installer during the procedure

Move the leafs to the mid position
Very important for a good result

- Press and hold the SETUP button until the SETUP LED lights up, keep it pressed for about 3 sec. until it turns off and keep it pressed more until the leaf 2 (if present) starts moving slowly. The LED will blink during the setup procedure
- Leaf 2 will move in closing direction until it reaches the mechanical stop or FCC2
- Leaf 1 starts moving slowly until it reaches the mechanical stop or FCC1
- Leaf 1 starts moving in opening direction at the set speed (trimmer speed).
- At the point where you want the slowdown to start give an OPEN A command with the push button or the remote that is already stored in memory. Leaf 1 starts to slow down and stops when it reaches the mechanical stop or FCA1.
- Leaf 2 starts moving in opening direction at the set speed (trimmer speed)

7. At the point where you want the slowdown to start give an OPEN A command with the push button or the remote that is already stored in memory. Leaf 2 starts to slow down and stops when it reaches the mechanical stop or FCA2.
8. Leaf 2 starts to close at the set speed (trimmer speed).
9. At the point where you want the slowdown to start give an OPEN A command with the push button or the remote that is already stored in memory. The leaf 2 starts to slow down and stops when it reaches the mechanical stop or FCC2.
10. Leaf 1 starts to close at the set speed (trimmer speed).
11. At the point where you want the slowdown to start give an OPEN A command with the push button or the remote that is already stored in memory. Leaf 1 starts to slow down and stops when it reaches the mechanical stop or FCC1.
12. The manual time learning procedure is complete.

6.3 OBSTACLE DETECTION FUNCTION

The obstacle detection function is achieved by controlling the current absorption and / or through the encoder connected to the motors.

If the gate encounters an obstacle during the movement of opening or closing, the obstacle detection function is activated and the operator reverses the direction of the gate.

In case of a second consecutive obstacle the operator stops the gate right away and any further command is inhibited. To re-enable the automation, you must remove power or open the STOP contact input. Until this "reset" the Audio Alarm output will be active.

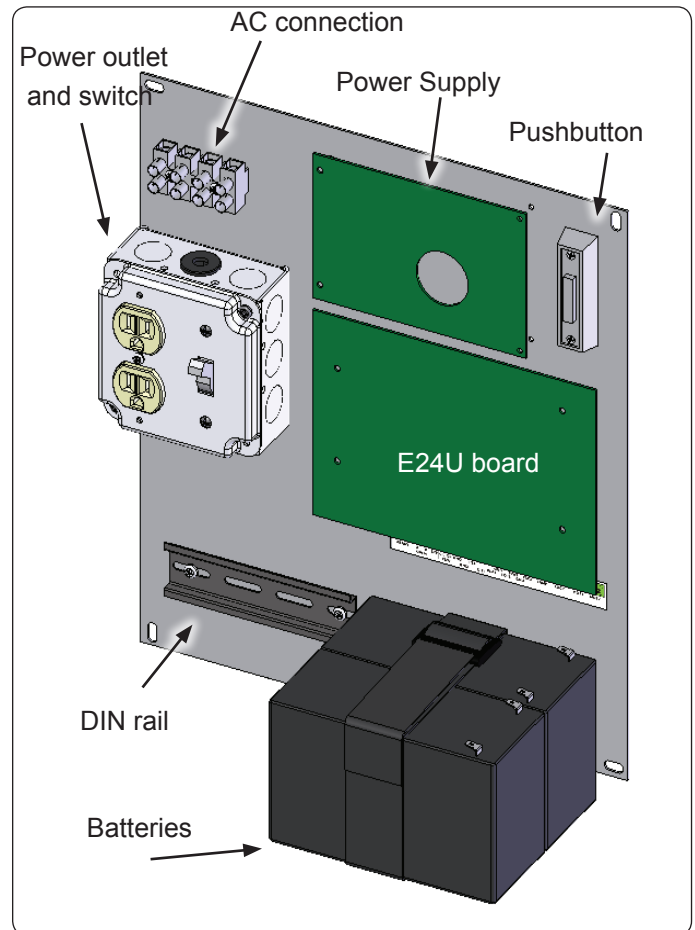

On the back panel are installed the control board, the power supply and additional accessories.

7. ENCLOSURE

The E024U board is supplied on a panel that fits in a 16x14" enclosure.

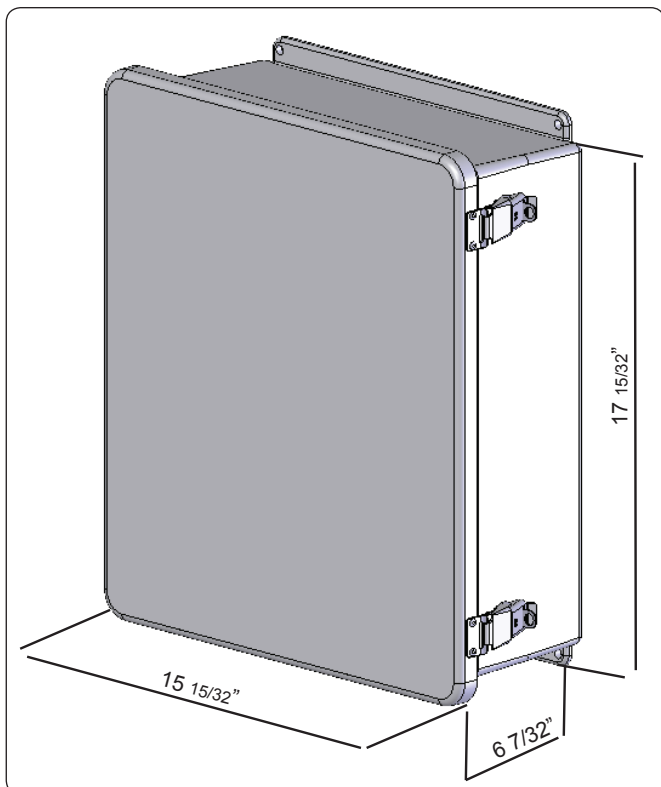

E024U CONTROL BOARD

8. POWER CONNECTION

AC POWER GUIDELINES:

THE E024U control board and power supply uses a single phase AC power line to operate, charge the batteries, and power gate accessories. Use the following guidelines when installing the AC power:

1. Check the local wiring codes in all cases and follow all local building codes. Wiring and hookup should be performed by a qualified electrician/installer only.
2. AC power should be supplied from a circuit breaker panel and must have its own dedicated circuit breaker. This supply must include a green ground conductor.
3. Use copper conductor wires with liquid tight flexible conduit UL listed for electric cable protection

14 AWG, 600V, 80°C
Terminal Block max Torque 2.1 Nm

4. Properly ground the gate operator to minimize or prevent damage from power surges and/or lightning. Use a grounding rod if necessary. A surge suppressor is recommended for additional protection.

AC POWER CONNECTION

To connect AC power to the controller:

1. Turn the circuit breaker for the AC gate operator power OFF before connecting the AC input wires.
2. Turn OFF the Power Switch located on the left side of enclosure before connecting the AC input wires.
3. Connect the AC input wires to the AC terminal located on the top left of the control box. See diagram below.
4. Batteries must be installed after the AC power is on. See Battery Power Connection.

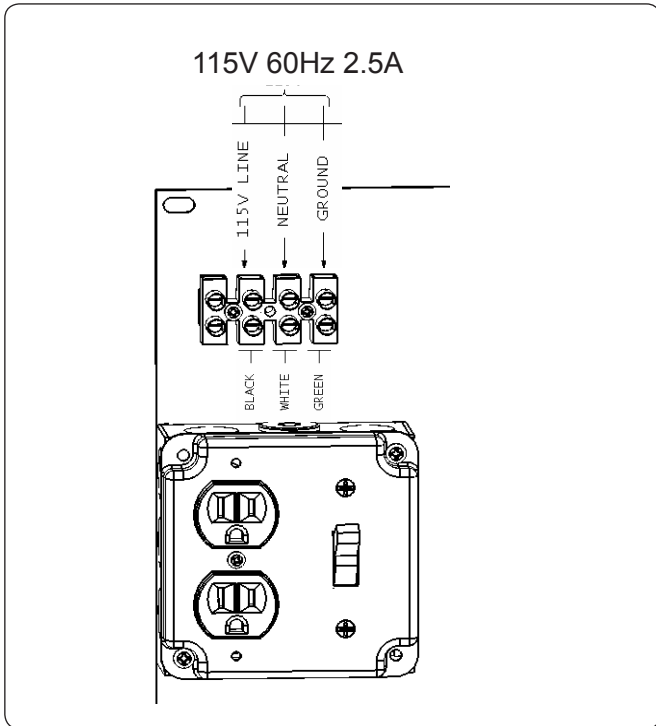

8.1 POWER SUPPLY

The E024U board is powered by a high efficiency switching power supply that takes 115V or 230V in input and provides 36VDC to power the board. The power supply is preset for 115V at the factory, consult with FAAC Tecnical Support for 230V wiring options.

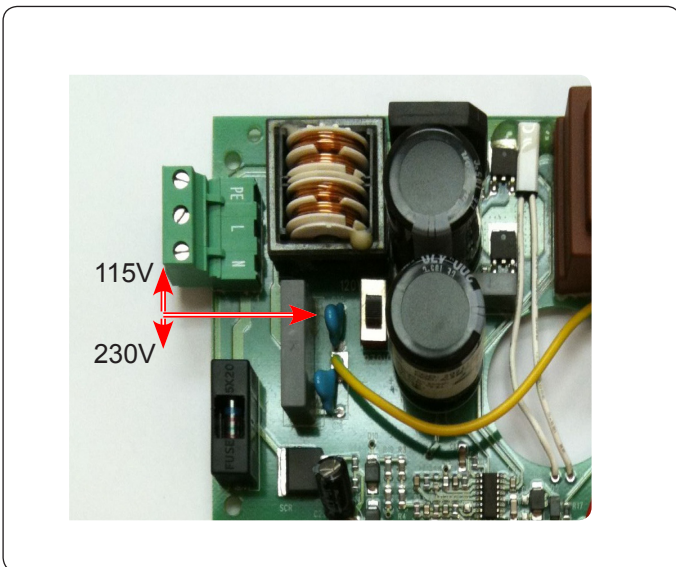

9. BACKUP BATTERY

The E024U board allows the connection of a 24V backup battery to provide power to operate the gate during blackouts. For more details about how the boards handles the loss of main power and how to configure its behaviour please see par 4.3 and DS1 switch 7.

To connect the battery use the provided cable and plug it on the BATTERY connector on the board. Plug the other end of the cable to the batteries, red wire to +24 and black wire to GND.

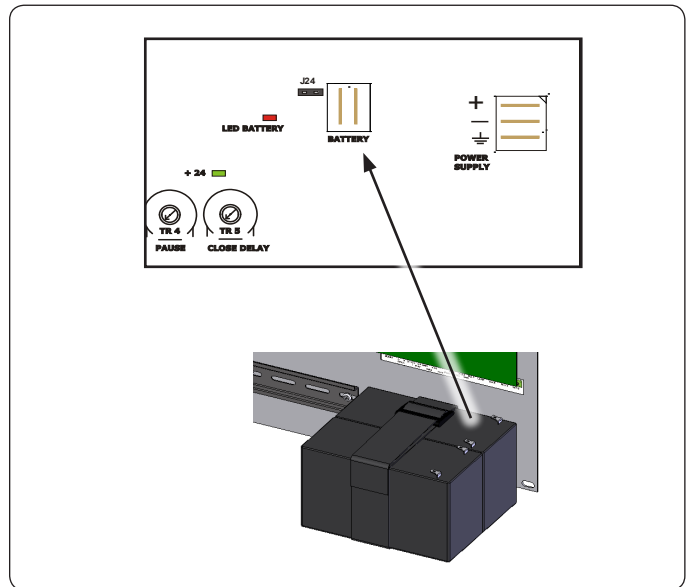

9.1 DISABLE THE BATTERY CHARGER

To disable the battery charger unplug jumper J24

J24 PRESENT = BATTERY CHARGING ACTIVE

J24 NOT PRESENT = BATTERY CHARGING NOT ACTIVE

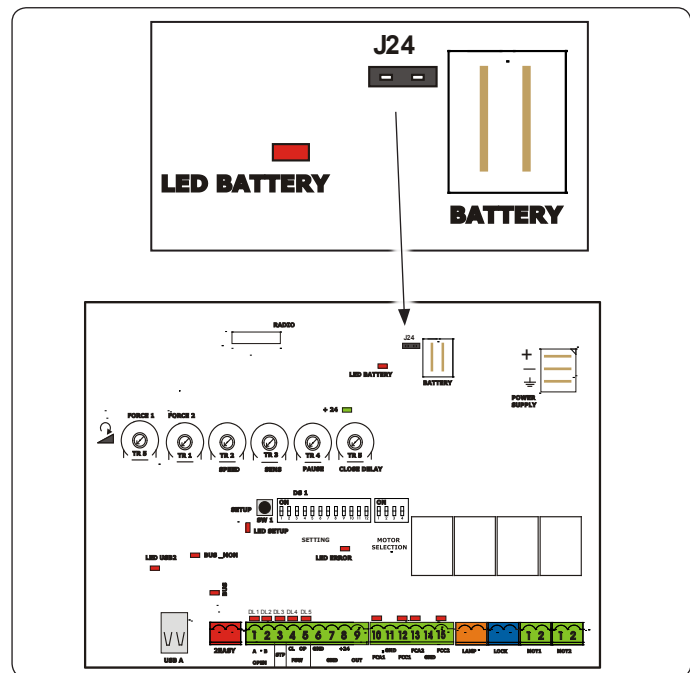

10. FIRMWARE UPGRADE

The E024U board keeps the operating firmware in a field programmable memory, it can be easily upgraded through the on board USB port

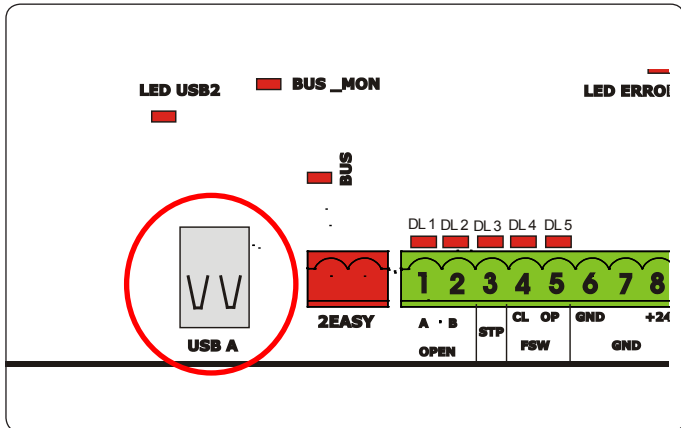

For the upgrade you need a USB Flash Drive, where you have to copy the file supplied by FAAC. Then follow these steps:

1. Disconnect the batteries if they are present.
2. Turn the AC power off and insert the Flash Drive into the USB A input on the board
3. Turn the AC power back on. The USB2 LED will start to flash to confirm the beginning of the software update. (WARNING: DON'T TURN THE POWER OFF OR REMOVE THE FLASH DRIVE UNTIL THE USB2 LED TURNS OFF.
4. Wait until the USB 2 LED turns off
5. Remove the USB Flash drive.
6. Cycle power, reconnect the batteries if needed and execute a new SETUP procedure (See chapter 6)



WARNING: Only upgrade the firmware with the proper file supplied by FAAC. otherwise the board could be damaged

11. FUNCTION LOGICS

LOGIC "E"	PULSES							
	SYSTEM STATUS	OPEN A	OPEN B	CLOSE	STOP	FSW OP	FSW CL	FSW CL/OP
CLOSED	opens the leaves	opens leaf 1	no effect	no effect (OPEN disabled)	no effect (OPEN disabled)	no effect	no effect	no effect (OPEN disabled)
OPENING	stops operation (1)	stops operation	recloses leaves immediately	stops operation	immediately reverses at closing	no effect	stops and opens at release (OPEN stops - saves CLOSE)	
OPEN	recloses leaves immediately (1)	recloses leaves immediately	recloses leaves immediately	no effect (OPEN/CLOSE disabled)	no effect	no effect (CLOSE disabled)	no effect (OPEN/CLOSE disabled)	
CLOSING	reopens leaves immediately	reopens leaves immediately	no effect	stops operation	no effect	reverses at opening	stops and opens at release (OPEN stops - saves CLOSE)	
BLOCKED	closes leaves	closes leaves	closes leaves	no effect (OPEN/CLOSE disabled)	no effect (OPEN disabled)	no effect (CLOSE disabled)	no effect (OPEN stops - saves CLOSE)	

(1) if the cycle began with OPEN-B (leaf 1), both leaves are activated at opening

LOGIC "A"	PULSES							
	SYSTEM STATUS	OPEN A	OPEN B	CLOSE	STOP	FSW OP	FSW CL	FSW CL/OP
CLOSED	opens and closes after pause time	opens leaf 1 and closes after pause time	no effect	no effect (OPEN disabled)	no effect (OPEN disabled)	no effect (OPEN disabled)	no effect	no effect (OPEN disabled)
OPENING	no effect (1)	no effect	recloses leaves immediately	stops operation	reverses at closing	no effect	stops and opens at release (saves CLOSE)	
OPEN IN PAUSE	reloads pause time (1)	reloads pause time of released leaf	recloses leaves immediately	stops operation	no effect	recharges pause time (CLOSE disabled)	recharges pause time (CLOSE disabled)	
CLOSING	reopens leaves immediately	reopens leaves immediately	no effect	stops operation	no effect	reverses at opening	stops and opens at release (saves CLOSE)	
BLOCKED	closes leaves	closes leaves	closes leaves	no effect (OPEN/CLOSE disabled)	no effect (OPEN disabled)	no effect (CLOSE disabled)	no effect (OPEN/CLOSE disabled)	

(1) if the cycle began with OPEN-B (leaf 1), both leaves are activated at opening

LOGIC "S"	PULSES						
SYSTEM STATUS	OPEN A	OPEN B	CLOSE	STOP	FSW OP	FSW CL	FSW CL/OP
CLOSED	opens and closes after pause time	opens released leaf and closes after pause time	no effect	no effect (OPEN disabled)	no effect (OPEN disabled)	no effect	no effect (OPEN disabled)
OPENING	no effect (1)	no effect	recloses leaves immediately	stops operation	reverses at closure	continues to open and recloses immediately	stops and opens at release (saves CLOSE)
OPEN IN PAUSE	recloses leaves immediately (1)	recloses leaves immediately	recloses leaves immediately	stops operation	no effect	stops and, at release, closes	stops and, at release, closes
CLOSING	reopens leaves immediately	reopens leaves immediately	no effect	stops operation	no effect	reverses at opening (see DS1-SW8) and closes immediately at end	stops and opens after release and closes immediately at end
BLOCKED	closes leaves	closes leaves	closes leaves	no effect (OPEN/CLOSE disabled)	no effect (OPEN disabled)	no effect (CLOSE disabled)	no effect (OPEN/CLOSE disabled)

(1) if the cycle began with OPEN-B (leaf 1), both leaves are activated at opening

LOGIC "EP"	PULSES						
SYSTEM STATUS	OPEN A	OPEN B	CLOSE	STOP	FSW OP	FSW CL	FSW CL/OP
CLOSED	opens the leaves	opens leaf 1	no effect	no effect (OPEN disabled)	no effect (OPEN disabled)	no effect	no effect (OPEN disabled)
OPENING	stops operation (1)	stops operation	recloses leaves immediately	stops operation	immediately reverses at closure	no effect	stops and opens at release (OPEN stops - saves CLOSE)
OPEN	recloses leaves immediately (1)	recloses leaves immediately	recloses leaves immediately	no effect (OPEN/CLOSE disabled)	no effect	no effect (CLOSE disabled)	no effect (OPEN/CLOSE disabled)
CLOSING	stops operation	stops operation	no effect	stops operation	no effect	reverses at opening	stops and opens at release (OPEN stops - saves CLOSE)
BLOCKED	restarts moving in opposite direction. Always closes after STOP	restarts moving in opposite direction. Always closes after STOP	closes leaves	no effect (OPEN/CLOSE disabled)	no effect (OPEN disabled)	no effect (CLOSE disabled)	no effect (OPEN stops - saves CLOSE)

(1) if the cycle began with OPEN-B (leaf 1), both leaves are activated at opening

LOGIC "AP"	PULSES						
SYSTEM STATUS	OPEN A	OPEN B	CLOSE	STOP	FSW OP	FSW CL	FSW CL/OP
CLOSED	opens and closes after pause time	opens leaf 1 and closes after pause time	no effect	no effect (OPEN disabled)	no effect (OPEN disabled)	no effect	no effect (OPEN disabled)
OPENING	stops operation (1)	stops operation	recloses leaves immediately	stops operation	reverses at closing (saves OPEN)	no effect	stops and opens at release (OPEN stops - saves CLOSE)
OPEN IN PAUSE	stops operation (1)	stops operation	recloses leaves immediately	stops operation	no effect	recharges pause time (CLOSE disabled)	recharges pause time (CLOSE disabled)
CLOSING	reopens leaves immediately	reopens leaves immediately	no effect	stops operation	no effect	reverses at opening (see DS1-SW8)	stops and opens at release (OPEN stops - saves CLOSE)
BLOCKED	closes leaves	closes leaves	closes leaves	no effect (OPEN/CLOSE disabled)	no effect (OPEN disabled)	no effect (CLOSE disabled)	no effect (OPEN/CLOSE disabled)

(1) if the cycle began with OPEN-B (leaf 1), both leaves are activated at opening

LOGIC "SP"	PULSES						
SYSTEM STATUS	OPEN A	OPEN B	CLOSE	STOP	FSW OP	FSW CL	FSW CL/OP
CLOSED	opens and closes after pause time	opens leaf 1 and closes after pause time	no effect	no effect (OPEN disabled)	no effect (OPEN disabled)	no effect	no effect (OPEN disabled)
OPENING	stops operation (1)	stops operation	recloses leaves immediately	stops operation	reverses at closure	continues to open and recloses immediately	stops and opens after release and closes immediately at end (OPEN stops - saves CLOSE)
OPEN IN PAUSE	recloses leaves immediately (1)	recloses leaves immediately	recloses leaves immediately	stops operation	no effect	stops and, at release, closes	stops and, at release, closes
CLOSING	stops operation	stops operation	no effect	stops operation	no effect	reverses at opening	stops and opens at release (saves CLOSE)
BLOCKED	restarts moving in opposite direction. Always closes after STOP	restarts moving in opposite direction. Always closes after STOP	recloses leaves immediately	no effect (OPEN/CLOSE disabled)	no effect (OPEN disabled)	no effect (CLOSE disabled)	no effect (OPEN/CLOSE disabled)

(1) if the cycle began with OPEN-B (leaf 1), both leaves are activated at opening

LOGIC "B"	PULSES						
SYSTEM STATUS	OPEN A	OPEN B	CLOSE	STOP	FSW OP	FSW CL	FSW CL/OP
CLOSED	opens the leaves	no effect	no effect	no effect (OPEN disabled)	no effect (OPEN disabled)	no effect	no effect (OPEN disabled)
OPENING	no effect	closes leaves	closes leaves	stops operation	reverses at closure	no effect	stops and, at release, closes (saves OPEN/CLOSE)
OPEN	no effect	closes leaves	closes leaves	no effect (OPEN/CLOSE disabled)	no effect	no effect (CLOSE disabled)	no effect (OPEN/CLOSE disabled)
CLOSING	opens the leaves	no effect	no effect	stops operation	no effect	reverses at opening	stops and opens at release (saves OPEN/CLOSE)
BLOCKED	opens the leaves	closes leaves	closes leaves	no effect (OPEN/CLOSE disabled)	no effect (OPEN disabled)	no effect (CLOSE disabled)	no effect (OPEN/CLOSE disabled)

LOGIC "C"	CONTINUOUS COMMANDS			PULSES			
SYSTEM STATUS	OPEN A	OPEN B	CLOSE	STOP	FSW OP	FSW CL	FSW CL/OP
CLOSED	opens the leaves	no effect	no effect	no effect (OPEN disabled)	no effect (OPEN disabled)	no effect	no effect (OPEN disabled)
OPENING	no effect	closes leaves	closes leaves	stops operation	reverses at closure	no effect	stops and, at release, closes (saves OPEN/CLOSE)
OPEN	no effect	closes leaves	closes leaves	no effect (OPEN/CLOSE disabled)	no effect	no effect (CLOSE disabled)	no effect (OPEN/CLOSE disabled)
CLOSING	opens the leaves	no effect	no effect	stops operation	no effect	reverses at opening	stops and opens at release (saves OPEN/CLOSE)
BLOCKED	opens the leaves	closes leaves	closes leaves	no effect (OPEN/CLOSE disabled)	no effect (OPEN disabled)	no effect (CLOSE disabled)	no effect (OPEN/CLOSE disabled)

LIMITED WARRANTY**To the original purchaser only:**

FAAC International, Inc., warrants, for twenty-four (24) months from the date of invoice, the gate operator systems and other related systems and equipment manufactured by FAAC S.p.A. and distributed by FAAC International, Inc., to be free from defects in material and workmanship under normal use and service for which it was intended provided it has been properly installed and operated.

FAAC International, Inc.'s obligations under this warranty shall be limited to the repair or exchange of any part of parts manufactured by FAAC S.p.A. and distributed by FAAC International, Inc. Defective products must be returned to FAAC International, Inc., freight prepaid by purchaser, within the warranty period. Items returned will be repaired or replaced, at FAAC International, Inc.'s option, upon an examination of the product by FAAC International, Inc., which discloses, to the satisfaction of FAAC International, Inc., that the item is defective. FAAC International, Inc. will return the warranted item freight prepaid. The products manufactured by FAAC S.p.A. and distributed by FAAC International, Inc., are not warranted to meet the specific requirements, if any, of safety codes of any particular state, municipality, or other jurisdiction, and neither FAAC S.p.A. or FAAC International, Inc., assume any risk or liability whatsoever resulting from the use thereof, whether used singly or in combination with other machines or apparatus.

Any products and parts not manufactured by FAAC S.p.A. and distributed by FAAC International, Inc., will carry only the warranty, if any, of the manufacturer. This warranty shall not apply to any products or parts thereof which have been repaired or altered, without FAAC International, Inc.'s written consent, outside of FAAC International, Inc.'s workshop, or altered in any way so as, in the judgment of FAAC International, Inc., to affect adversely the stability or reliability of the product(s) or has been subject to misuse, negligence, or accident, or has not been operated in accordance with FAAC International, Inc.'s or FAAC S.p.A.'s instructions or has been operated under conditions more severe than, or otherwise exceeding, those set forth in the specifications for such product(s). Neither FAAC S.p.A. nor FAAC International, Inc., shall be liable for any loss or damage whatsoever resulting, directly or indirectly, from the use or loss of use of the product(s). Without limiting the foregoing, this exclusion from liability embraces a

purchaser's expenses for downtime or for making up downtime, damages for which the purchaser may be liable to other persons, damages to property, and injury to or death of any persons.

FAAC S.p.A. or FAAC International, Inc., neither assumes nor authorizes any person to assume for them any other liability in connection with the sale or use of the products of FAAC S.p.A. or FAAC International, Inc. The warranty herein above set forth shall not be deemed to cover maintenance parts, including, but not limited to, hydraulic oil, filters, or the like. No agreement to replace or repair shall constitute an admission by FAAC S.p.A. or FAAC International, Inc., of any legal responsibility to effect such replacement, to make such repair, or otherwise. This limited warranty extends only to wholesale customers who buy directly through FAAC International, Inc.'s normal distribution channels. FAAC International, Inc., does not warrant its products to end consumers.

Consumers must inquire from their selling dealer as to the nature and extent of that dealer's warranty, if any. This warranty is expressly in lieu of all other warranties expressed or implied including the warranties of merchantability and fitness for use. This warranty shall not apply to products or any part thereof which have been subject to accident, negligence, alteration, abuse, or misuse or if damage was due to improper installation or use of improper power source, or if damage was caused by fire, flood, lightning, electrical power surge, explosion, wind storm, hail, aircraft or vehicles, vandalism, riot or civil commotion, or acts of God.