

# The 760 Operator and 450 MPS Control Panel: Installation Manual

## Contents

- Important Safety Information ..... 2
- Technical Data ..... 4
- The 760 Operator..... 4
- The Control Panel..... 4
- Unpacking the Operator ..... 5
- The 760 Swing Gate Operator ..... 6
- General Characteristics ..... 6
- 450 MPS Logic Modes ..... 6
- Installation Instructions..... 9
- Preparing the Gate ..... 9
- Manual Release..... 10
- Installing the 760 Operator ..... 10
- Install the Load Bearing Box..... 10
- Secure the Load Bearing Box..... 11
- Install the Gate Leaf Shoe..... 11
- Install the Gate Leaf..... 14
- Install the Operator in the Load Bearing Box..... 14
- Install the 450 MPS Control Panel ..... 16
- Connect the Main Power Supply..... 16
- Connect the Operator(s) to the Control Panel..... 17
- Check the Motor's Direction of Rotation..... 19
- Connect Other Devices..... 19
- Set Operating Controls..... 21
- Fine-tune the Bypass Valve Pressures ..... 22
- Adjust the Beginning of the Braking Phase ..... 23
- Adjust the Braking Intensity ..... 23
- Assemble and Install the Manual Release ..... 23
- Installing an Extension Arm..... 25
- Maintenance ..... 26
- The 760 Operator..... 26
- The Control Panel..... 26
- Troubleshooting ..... 27
- Exploded View, 760 Splined Shaft..... 28
- Exploded View, 760 CBAC-SB-SBS..... 29
- Exploded View, 760 CR..... 30

**FAAC International, Inc.**  
**303 Lexington Avenue**  
**Cheyenne, WY 82007**  
**www.faacusa.com**



# Important Safety Information

Both the installer and the owner and/or operator of this system need to read and understand this installation manual and the safety instructions supplied with other components of the gate system. This information should be retained by the owner and/or operator of the gate.

---

**WARNING!** To reduce the risk of injury or death

1. **READ AND FOLLOW ALL INSTRUCTIONS.**
2. Never let children operate or play with gate controls. Keep the remote control away from children.
3. Always keep people and objects away from the gate. **NO ONE SHOULD CROSS THE PATH OF THE MOVING GATE.**
4. Test the gate operator monthly. The gate **MUST** reverse on contact with a rigid object or stop when an object activates the non-contact sensors. After adjusting the force or the limit of travel, retest the gate operator. Failure to adjust and retest the gate operator properly can increase the risk of injury or death.
5. Use the emergency release only when the gate is not moving.
6. **KEEP GATES PROPERLY MAINTAINED.** Read the owner's manual. Have a qualified service person make repairs to gate hardware.
7. The entrance is for vehicles only. Pedestrians must use separate entrance.
8. **SAVE THESE INSTRUCTIONS.**

When installing the photo-beams supplied with this unit two things need to be considered.

1. Care should be exercised to reduce the risk of nuisance tripping, such as when a vehicle, trips the sensor while the gate is in motion.
2. One or more photobeams shall be located where the risk of entrapment exists, such as the perimeter reachable by the moving gate leaf.

## Gate Design

1. A gate is a potential traffic hazard, so it is important that you locate the gate far enough away from the road to eliminate the potential of traffic getting backed up. This distance is affected by the size of the gate, how often it is used, and how fast the gate operates.
2. The operator you choose to install on your gate must be designed for the type and size of your gate and for the frequency with which you use the operator.
3. Your gate must be properly installed and must work freely in both directions before the automatic operator is installed.
4. An automatic operator should be installed on the inside of the property/fence line. Do not install the operator on the public side of the property/fence line.
5. Pedestrians should not use a vehicular gate system. Prevent such inappropriate use by installing separate gates for pedestrians.
6. Exposed, reachable pinch points on a gate are potentially hazardous and must be eliminated or guarded.
7. Outward swinging gates with automatic operators should not open into a public area.
8. The operating controls for an automatic gate must be secured to prevent the unauthorized use of those controls.
9. The controls for an automatic gate should be located far enough from the gate so that a user cannot accidentally touch the gate when operating the controls.
10. An automatic gate operator should not be installed on a gate if people can reach or extend their arms or legs through the gate. Such gates should be guarded or screened to prevent such access.

## Installation

1. If you have any question about the safety of the gate operating system, do not install this operator. Consult the operator manufacturer.
2. The condition of the gate structure itself directly affects the reliability and safety of the gate operator.
3. Only qualified personnel should install this equipment. Failure to meet this requirement could cause severe injury and/or death, for which the manufacturer cannot be held responsible.

4. The installer must provide a main power switch that meets all applicable safety regulations.
  5. Clearly indicate on the gate with the 2 warning signs that are included (visible from either side of the gate).
  6. It is extremely unsafe to compensate for a damaged gate by increasing hydraulic pressure.
  7. Devices such as reversing edges and photocells must be installed to provide better protection for personal property and pedestrians. Install reversing devices that are appropriate to the gate design and gate application.
  8. Before applying electrical power, be sure that the voltage requirements of the equipment correspond to your supply voltage. Refer to the label on your operator system.
- Do not touch the equipment with damp or humid hands or feet.
  - Do not install or operate the equipment with bare feet.
  - Do not allow small children or incapable persons to use the equipment.
3. If a gate system component malfunctions, turn off the main power before making any attempt to repair it.
  4. Do not attempt to impede the movement of the gate. You may injure yourself as a result.
  5. This equipment may reach high temperatures during operation; therefore, use caution when touching the external housing of the operator.
  6. Learn to use the manual release mechanism according to the procedures found in this installation manual.
  7. Before carrying out any cleaning or maintenance operations, disconnect the equipment from the electrical supply.
  8. To guarantee the efficiency of this equipment, the manufacturer recommends that qualified personnel periodically check and maintain the equipment.

**Use**

1. Use this equipment only in the capacity for which it was designed. Any use other than that stated should be considered improper and therefore dangerous.
2. When using any electrical equipment, observe some fundamental rules:

U.L. Class and FAAC Operator Model		Duty Cycle	Typical Use
<b>Class I: Residential Vehicular Gate Operator</b>			
402	750	Limited duty	<ul style="list-style-type: none"> <li>• Home use</li> <li>• Small apartment building, for example, up to 4 units in a building, with limited public access</li> </ul>
422	760		
412	400		
620	640		
<b>Class II: Commercial/General Access Vehicular Gate Operator</b>			
400	640	Continuous duty	<ul style="list-style-type: none"> <li>• Apartment buildings</li> <li>• Very public access</li> </ul>
620			
<b>Class III: Industrial/Limited Access Vehicular Gate Operator</b>			
400	640	Continuous duty	<ul style="list-style-type: none"> <li>• No public access</li> </ul>
620			
<b>Class IV: Restricted Access Vehicular Gate Operator</b>			
620	640	Continuous duty	<ul style="list-style-type: none"> <li>• Prison rated security</li> </ul>

# Technical Data

## The 760 Operator

Parameter	760 Standard	760 Longer Leaf	760 Extra Long Leaf
Ambient temperature, deg F (deg C)	-4 to 131 (-20 to 55)		
Maximum duty cycle, cycles per hour.	30		
Thermal cut out, deg F (deg C)	212 (100)		
Power voltage required, VAC*	115, ±10% or 230, +6 or -10%, 60 Hz*	230, +6 or -10%,	
Absorbed power, W	220		
Current drawn, A	230VAC= 1A, 115VAC= 1.5A	0.8A	
Motor speed, rpm	1400	960	
Type of oil	Lubrication Engineers – MONOLEC 6105		
Height (excluding spline) × width × depth, in. (cm)	6 <sup>1</sup> / <sub>4</sub> × 10 <sup>1</sup> / <sub>4</sub> × 19 <sup>1</sup> / <sub>4</sub> (15.9 × 26 × 49)		
Weight, lb (kg)	28 <sup>1</sup> / <sub>2</sub> (13)		
Oil quantity, qt (l)	1 <sup>1</sup> / <sub>4</sub> (1.2)		
Hydraulic locking	Opened and closed	Not available	Not available
Maximum gate weight, lb (kg)	1760 (800)		
Maximum gate length, ft (m)	7 (2.1)	10 (3)	13 (4)
Maximum angle of rotation, deg	148 degrees		
90-deg opening time, sec	12**		17**
Nominal torque, ft-lb (Nm)	399 (543)		200 (272)

\* Your standard 220 VAC power source meets the specification for 230 VAC, +6 or -10%.

\*\* Plus additional time for soft-stop versions

## The Control Panel

The 760 Operator must be installed with a 450 MPS control panel to be a U.L. recognized installation. The 450 MPS can be used to control a single 760 operator or a dual (biparting) system. Both the control panel and the operator must use the same power supply voltage.

### The 450 MPS

To determine the voltage requirement of your 450 MPS control panel, refer to the label on the transformer of the control panel:

Label reads: 1450MPSUS = 220 VAC

1450MPSUS115 = 115 VAC

Operating logics available: E, EP, A, S, B, and C

(See pages 6, 7, & 8)

# Unpacking the Operator

When you receive your 760 Operator, inspect the shipping boxes for physical damage such as leaking oil or a torn carton. Then inspect the operator, the mounting box, and the control panel after you remove them from the boxes. Notify the carrier immediately if you note any damage because the carrier must witness the damage before you can file a claim.

As you unpack the boxes, insure that all the parts listed below are included.

## 760 Operator:

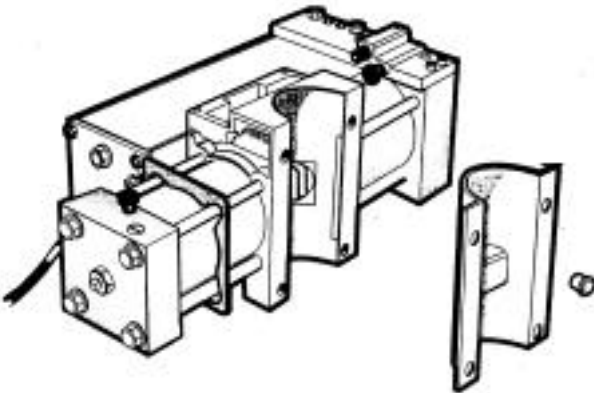
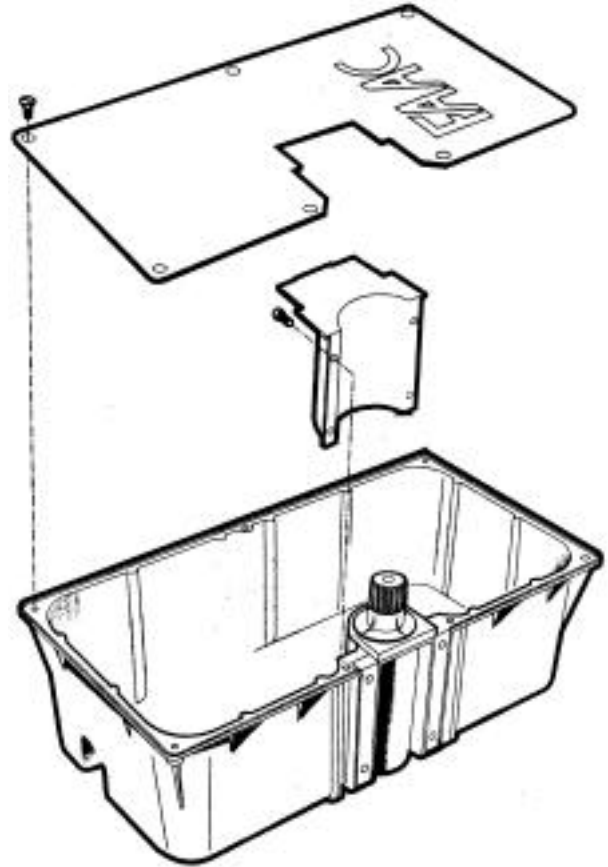

**Figure 1. Hydraulic pump/ drive assembly with a plastic shipping cover fitted over the rack.**

## Package containing:

- 4 bolts and 4 lock washers for attaching the 760 Operator to the load bearing box.
- 1 unassembled Manual Release housing and its necessary screws and nuts.
- 1 brass rod with a plastic gear and a second brass gear assembly with key, spacer, and disc for limiting access to one side.

## Load Bearing Box:



**Figure 2. Cast aluminum box with stainless steel lid; inside, a pinion cover is attached to the box with 4 screws.**

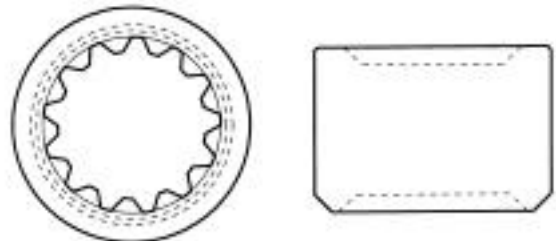

**Figure 3. The Splined Collar, which comes on the shaft of the Load Bearing Box, attaches to the gate.**

# The 760 Swing Gate Operator

## General Characteristics

The 760 Operator with *GentleSwing*<sup>™</sup> Motion Management is a medium-duty operator designed to swing a gate leaf from an unobtrusive in-ground installation, thus preserving the appearance of the gate. A 760 Operator system consists of a hydraulic unit in an in-ground box and a control panel.

The 760 Operator is designed for gates swinging open up to a maximum of 148 degrees with a 90-deg opening time of either 12 or 18 sec (see *Technical Data* on page 3), depending on the model. The soft-stop versions of the 760 Operator brake the movement of the gate during the last 10 deg of swing in both the opening and closing directions provided the gate opens 90 deg or more.

Once installed, the 760 Operator can be removed from the load bearing box without having to remove the gate.

For all models, the axis of rotation for the gate leaf must fall along an imaginary plumb line that is **at least** 1 3/8 in. (3.5 cm) away from the gate side of the pillar.

The hydraulic locking of the 760 Standard models is a service feature that helps to keep a gate fully opened or fully closed. However, we recommend external locking mechanisms for any one of the following situations:

- Your gate leaf is 10 ft (3 m) or longer.
- Your installation site requires tight security.
- You are installing the Model 760 SB or SBS.
- Your gate site is subject to vandalism.
- Your gate site is subject to strong or gusty wind.
- You are installing a solid faced gate.

For gates with two leaves, an operator is installed on each leaf. The single control panel can be programmed to swing one gate leaf slightly later than the other to allow for overlapping gate leaves.

The 760 Operator has two bypass valves that control the thrust of the gate leaves. You adjust the two bypass valves located on the 760 Operator to vary the force of the gate as it opens or closes.

Adjusting the bypass valves is necessary for the safety of both people and property. FAAC safety standards state that the gate should stop its movement if it encounters a force of more than about 33 lb. The installer of the 760 Operator makes the necessary adjustments to insure safe pressures.

A Manual Release disengages the hydraulic system on the Standard model of the 760 Operator and allows you to operate the gate by hand from either side of the gate (see Figure 6).

Additional devices (such as photobeams and inductive loops) should be installed to provide more complete safety for people and property.

The electronic control panel is a microprocessor-based controller that accepts a wide range of product accessories and reversing devices, thus allowing for a flexible gate system design.

## 450 MPS Logic Modes

**Note:** The 450 provides inputs for opening reversing devices and closing reversing devices. FAAC strongly recommends the use of reversing devices, such as photobeams or other non-contact sensors.

- **A (automatic):** The gate opens on command and automatically closes after a pause phase. A second command on opening is ignored; a second command during the pause phase interrupts the pause time; a second command during closing reopens the gate. A maintained open command will open the gate and hold it open.
- **S (security):** The security mode is like A logic except that a second command during opening immediately closes the gate. A maintained open command does not hold the gate open.
- **E (semi-automatic):** This mode requires a command to open and a command to close. A second command during opening or closing causes the gate leaves to stop. A third command then closes the gate.
- **EP (semi-automatic, step by step):** This mode requires a command to open and a command to close. A second command during opening or closing causes the gate leaves to stop. A third command then reverses the previous motion of the gate.
- **B (manned, pulsed):** This mode is designed for guard station use and requires a three-button switch (pulsed) to open, close, and stop the gate.
- **C (manned and constant):** This mode requires constant pressure switches. One to open and one to close. No pressure on a switch stops the gate.

### A (Automatic) Logic

Gate Status	Open A	Open B	Stop	Opening Reversing Device(s)	Closing Reversing Device(s)	Warning Light
<b>Closed</b>	Opens both leaves and closes them after pause time	Opens single leaf connected to Motor 1 and closes it after pause time	No effect	No effect	No effect	Off
<b>Opening</b>	No effect	No effect	Stops	Stops; gate closes when reversing device no longer triggered	No effect	On
<b>Opened</b>	Interrupts the pause time	Interrupts the pause time	Stops	No effect	Gate remains open until reversing devices no longer triggered	On
<b>Closing</b>	Opens both leaves immediately	Opens leaf immediately	Stops	No effect	Depends on DIP switch 4	Flashes
<b>Stopped</b>	Closes the leaves	Closes the leaf	No effect (opening is inhibited)	No effect	No effect (opening is inhibited)	On

### S (Security) Logic

Gate Status	Open A	Open B	Stop	Opening Reversing Device(s)	Closing Reversing Device(s)	Warning Light
<b>Closed</b>	Opens both leaves and closes them after pause time	Opens single leaf connected to Motor 1 and closes it after pause time	No effect	No effect	No effect	Off
<b>Opening</b>	Closes both leaves immediately	Closes the leaf immediately	Stops	Stops; gate closes when reversing device no longer triggered	No effect	On
<b>Opened</b>	Closes both leaves immediately	Closes leaf immediately	Stops	No effect	Gate remains open until reversing devices no longer triggered	On
<b>Closing</b>	Opens both leaves immediately	Opens leaf immediately	Stops	No effect	Depends on DIP switch 4	Flashes
<b>Stopped</b>	Closes the leaves	Closes the leaf	No effect (opening is inhibited)	No effect	No effect (opening is inhibited)	On

### B (Manned, Pulsed) Logic

Gate Status	Open A	Open B	Stop	Opening Reversing Device(s)	Closing Reversing Device(s)	Warning Light
<b>Closed</b>	Opens 1 or both leaves	No effect	No effect	No effect	No effect	Off
<b>Opening</b>	No effect	No effect	Stops	No effect	Stops	On
<b>Opened</b>	No effect	Closes 1 or both leaves	No effect	No effect	No effect	On
<b>Closing</b>	No effect	No effect	Stops	Stops	No effect	Flashes
<b>Stopped</b>	Opens 1 or both leaves	Closes 1 or both leaves	No effect	No effect	No effect	On

### E (Semi-automatic) Logic

Gate Status	Open A	Open B	Stop	Opening Reversing Device(s)	Closing Reversing Device(s)	Warning Light
<b>Closed</b>	Opens both leaves	Opens single leaf connected to Motor 1	No effect	No effect	No effect	Off
<b>Opening</b>	Stops	Stops	Stops	Stops; gate closes when reversing device no longer triggered	No effect	On
<b>Opened</b>	Closes both leaves immediately	Closes leaf immediately	Stops	No effect	No effect (opening is inhibited)	On
<b>Closings</b>	Stops	Stops	Stops	No effect (opening is inhibited)	Depends on DIP switch 4	Flashes
<b>Stopped</b>	Closes the leaves	Closes the leaf	No effect (opening is inhibited)	No effect	No effect (opening is inhibited)	On

### EP (Semi-automatic, Step by Step) Logic

Gate Status	Open A	Open B	Stop	Opening Reversing Device(s)	Closing Reversing Device(s)	Warning Light
<b>Closed</b>	Opens both leaves	Opens single leaf connected to Motor 1	No effect (opening is inhibited)	No effect (opening is inhibited)	No effect (opening is inhibited)	Off
<b>Opening</b>	Stops	Stops	Stops	Stops; gate closes when reversing device no longer triggered	No effect	On
<b>Opened</b>	Closes both leaves immediately	Closes leaf immediately	Stops	No effect	No effect (opening is inhibited)	On
<b>Closing</b>	Stops	Stops	Stops	No effect (opening is inhibited)	Depends on DIP switch 4	Flashes
<b>Stopped</b>	Gate leaves reverse direction	Gate leaf reverses direction	No effect (opening is inhibited)	No effect (opening is inhibited)	No effect (opening is inhibited)	On

### C (Manned and Constant) Logic

Gate Status	Open A	Open B	Stop	Opening Reversing Device(s)	Closing Reversing Device(s)	Warning Light
<b>Closed</b>	Opens 1 or both leaves	No effect	No effect	No effect	No effect	Off
<b>Opening</b>	No effect	No effect	Stops	No effect	Stops	On
<b>Opened</b>	No effect	Closes 1 or both leaves	No effect	No effect	No effect	On
<b>Closing</b>	No effect	No effect	Stops	Stops	No effect	Flashes
<b>Stopped</b>	Opens 1 or both leaves	Closes 1 or both leaves	No effect	No effect	No effect	On



# Installation Instructions

**Note:** The following installation instructions assume you are fully capable of installing a gate operator. This manual does not instruct you in designing a gate, installing a gate, or basic electrical wiring. The installation tasks discussed in this manual are tasks particular to the 760 Operator.

## Preparing the Gate

Before you install the 760 Operator, you must insure that the gate leaf meets the following criteria.

1. The gate leaf must not exceed the weight, length, or height constraints for the operator you are installing (see page 3). If you are retrofitting the 760 Operator to an existing gate, you need to insure that the axis of rotation through the hinge(s) and splined shaft is perfectly plumb.
2. The distance between the gate post and the center of the gate hinge must be **at least** 1 3/8 in. (3.5 cm). (see Figure 4)
3. Make sure the gate leaf has positive stops in both the opening and closing directions (see Figure 5).

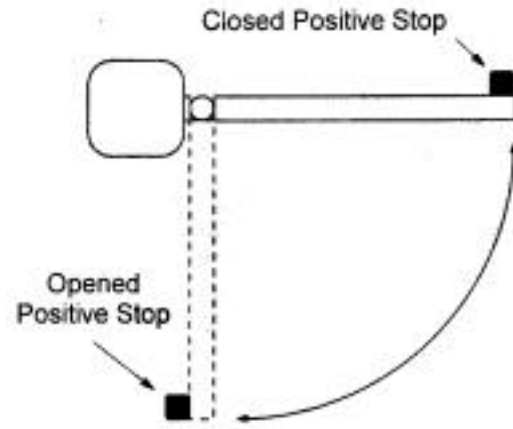

**Figure 5. Positive stops are required in the fully opened and fully closed gate positions**

4. You need to determine a means of attaching the splined collar to the gate. If the gate leaf is steel, you may be able to weld the collar directly to the gate. If the bottom of the gate is more than 2 1/8 in. above grade level you will have to extend the collar with pipe or round stock. If your gate is aluminum or wood, you will have to weld the collar to a steel plate or shoe that can be bolted to the bottom of the gate.

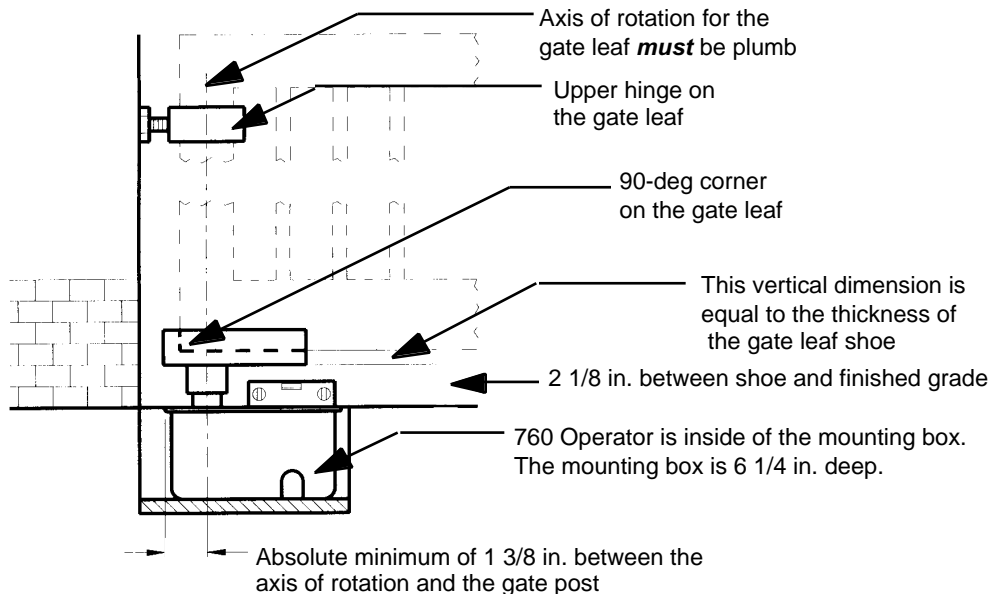

**Figure 4. Constraints on the geometry of the gate leaf (Single hinge installation shown)**

**Note:** If you are installing the 760 Operator with an extension arm, some of the constraints do not apply to your gate leaf. See the section "Installing an Extension Arm" for more information (page 25).

## Manual Release

**Note:** The 760 CBAC provides a Manual Release for manually operating the gate. Although the 760 SB and the 760 SBS come with this release mechanism, it is not necessary to use this feature to release the gate. The SB and SBS have no internal locking and can be pushed manually at any time.

The Manual Release mechanism on the Standard models is a built-in release device of the 760 Operator (see Figure 6). This device is accessible from both sides of the gate. You disengage the hydraulic operation of the operator by opening the access door (there is one on either side of the manual release housing), inserting the triangular key, and turning the key toward the gate post one full turn. Then you can move the gate by hand to open or close the gate. Operating the gate by hand is necessary during installation and is useful during power failures.

To re-engage the hydraulic operation of the gate, turn the key away from the gate post until resistance is met.

1. Open the access door to the release device
2. Insert the key and turn it one full turn toward the gate post for release.

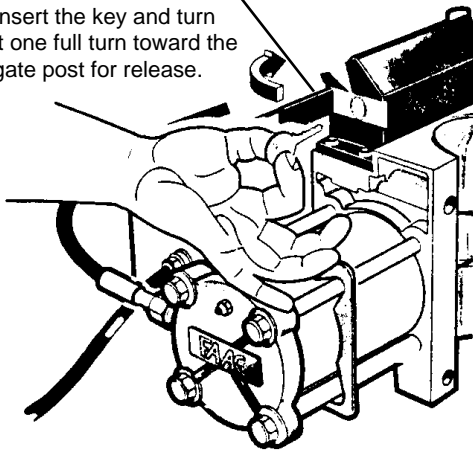

**Figure 6. The Manual Release in the 760 Standard Operator**

## Installing the 760 Operator

Installing the 760 Operator consists of the following steps:

- Install the load bearing box, electrical conduit, and drain pipe
- Secure the load bearing box
- Install the gate leaf shoe
- Install the gate leaf
- Install the operator in the load bearing box
- Install the control panel
- Adjust the hydraulic pressures for the operator
- Check the motor rotation
- Fine-tune the bypass valve pressures

## Install the Load Bearing Box

You need to excavate a cavity for the load bearing box of the 760 Operator according to the dimensions shown in Figures 4 and 7. (Your soil conditions will also determine the size of the cavity.) Accurately positioning the splined shaft of the pinion (inside the mounting box) beneath the gate hinge is critical. Proper alignment will ensure a full swing without binding.

**Note:** You need to insure that the load bearing box is well drained by means of pipes, gravel drainage, or both, whatever is appropriate for your soil conditions. Use one of the access holes in the load bearing box for the drainage pipe leaving the box.

Install your electrical conduit through another hole in the load bearing box. Use conduit of sufficient size and quality to accommodate the high-voltage wiring that must run between the operator (in the load bearing box) and the control panel.

**Caution:** Be sure to conform to all applicable electrical codes.

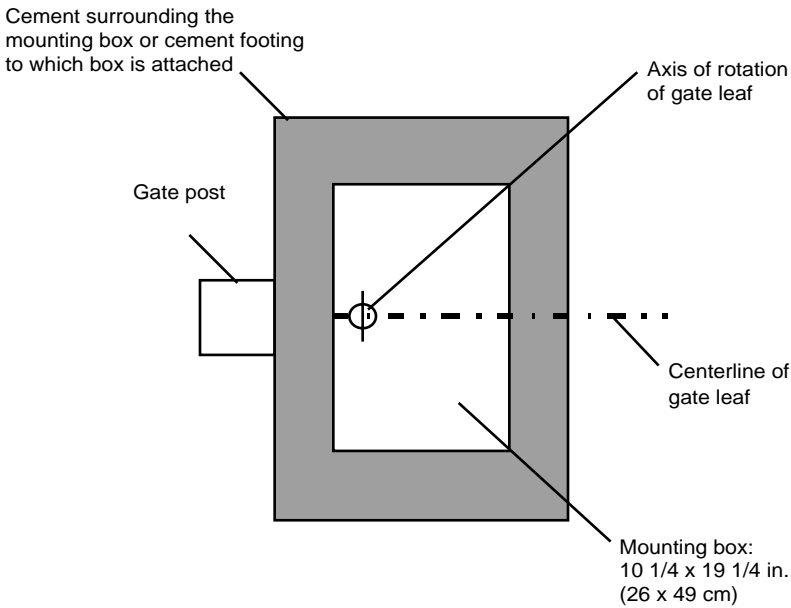

**Figure 7. The orientation of the load bearing box and concrete when you secure the load bearing box**

You next need to test fit the load bearing box in the cavity. The fit must meet the following requirements:

1. The center of the splined shaft of the pinion must align perfectly with the axis of rotation for the gate leaf. *Use a plumb line to insure this vertical alignment.*
2. The cover of the load bearing box should be even with the finished grade beneath the gate, but more importantly, the top edges of the load bearing box must be level. *Use a level to insure this horizontal alignment.*

## Secure the Load Bearing Box

Next you need to fix the mounting box in place if it meets all the requirements for alignment. Precisely how you fix the box in place will vary according to your soil conditions and your installation site.

**Example:** For example, you might surround the exterior of the mounting box with enough soil to extend 1/2 way up the box—so that soil covers the access holes for the electrical conduit and drainage pipe. While such soil should be firmly packed around the box, you have to be sure that in packing the soil you do not misalign the center of the splined shaft of the pinion or the top edge of the box. In fact, you should recheck all alignments and adjust the mounting box if necessary. Then you can pour concrete around the box and up to its top edge so as to be level with the finished grade beneath the gate leaf.

**Example:** As another example, you might use a foundation plate set in a cement footing. Then you could bolt the mounting box to the plate, taking care that your bolts do not interfere with the 760 Operator yet to be installed in the box. This method requires you to compensate for the unevenness of the bottom of the mounting box.

**Note:** No matter what your method of fixing the mounting box in place, use sufficient concrete to hold the mounting box in place when it is under the stresses inherent in hydraulically swinging the gate.

No matter how you secure the mounting box, if you use poured concrete, allow a minimum of two full days before you install the 760 Operator inside the mounting box.

## Install the Gate Leaf Shoe

**Note:** Building a gate leaf shoe is not absolutely necessary. It is a method that will work in most applications. However, if you wish to weld the splined collar directly to the gate or attach it by some other means, feel free to do so.

**Caution:** Do not install the gate leaf shoe, even for test fitting, until any concrete beneath or around the mounting box has had a chance to set for a minimum of two full days.

If the vertical distance between the finished grade under the gate and the bottom of the gate leaf is more than 2 3/8 in. (see Figure 4), you need to do one of the following:

- Install a length of appropriately sized pipe between the splined collar of the operator and the gate leaf shoe.
- Construct a shear-pin assembly to accommodate the extra vertical distance. The assembly is welded to the bottom of the gate or gate leaf shoe on one end and to the sleeve for the splined collar on the other end (see Figures 8 and 9). Such an assembly requires a gate with two hinges and also protects the pinion and splined shaft in the event something hits the gate with great force.

Installing the gate leaf shoe involves making the gate leaf shoe, positioning it, and welding it to the splined collar.

The gate leaf shoe is designed to carry the weight of the gate leaf and transfer the weight to the splined shaft of the pinion.

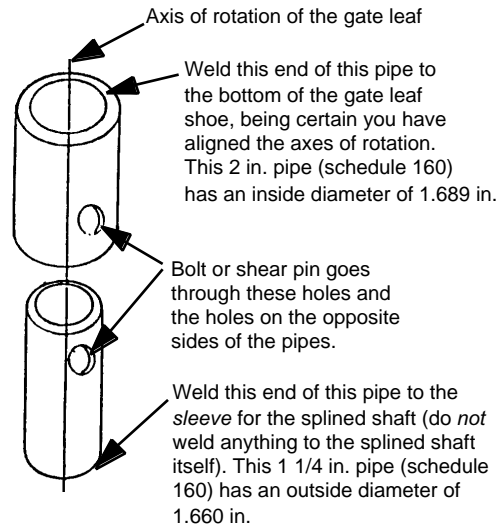

**Figure 8. A sample shear-pin assembly**

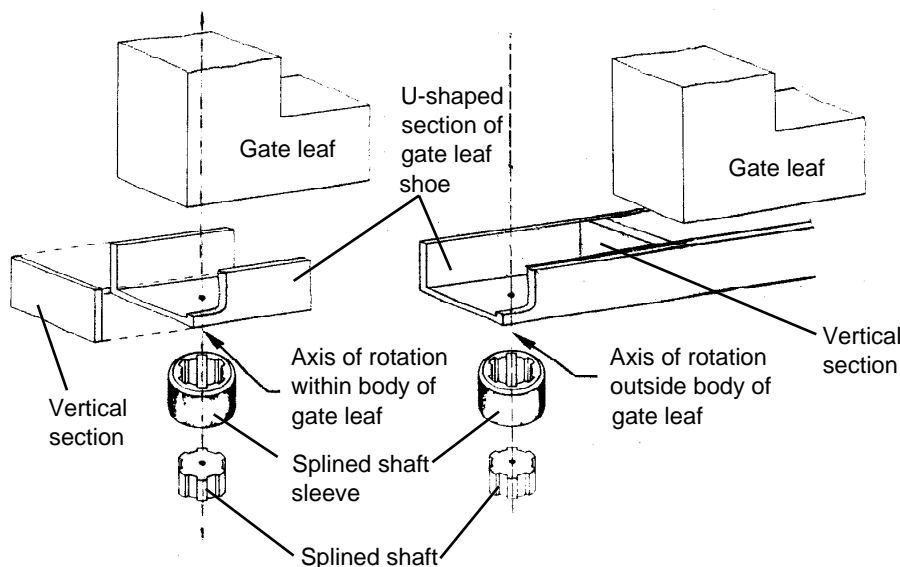

**Note:** The gate's axis of rotation may fall within or outside the body of the gate leaf.

**Figure 9. Parts of the gate leaf shoe**

The shoe is made of a U-shaped section and a vertical section (see Figure 9). Later you will weld the bottom of the U-shaped section to the sleeve for the splined shaft (or to the shear-pin assembly, which is welded to the splined collar).

Since the gate leaf shoe holds the gate leaf, both sections must be made of steel at least 1/4 in. (0.6 cm) thick. The U-shaped section of the shoe must be a minimum of 5 3/4 in. (2.1 cm) long and must be as wide as the gate leaf is thick and must fit as tightly as possible to minimize leaf movement within the shoe (see Figure 10).

Construct the U-shaped section of the shoe and verify that it fits around the gate leaf. Position the U-shaped section over the splined shaft so that the leaf's axis of rotation will fall within the minimum dimensions shown in Figure 10.

On the U-shaped section of the shoe, mark the position for the leaf's axis of rotation. Next, drill a pilot hole in the U-shaped section to mark the axis of rotation point

and mark the position for the placement of the vertical section of the shoe.

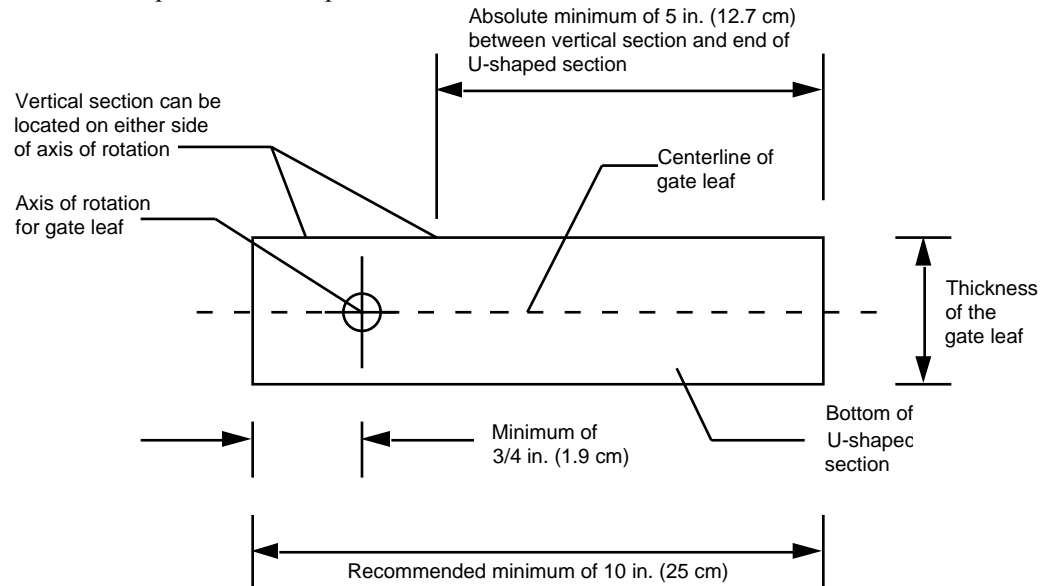

**Figure 10. Top view of the U-shaped section of the gate leaf shoe**

Next you need to position the splined collar (or the shear-pin assembly) on the bottom side of the U-shaped section of the shoe as shown in Figure 9. In positioning the splined collar, meet the following two requirements:

1. On the bottom of the U-shaped shoe section, accurately center the sleeve around the pilot hole that marks the axis of rotation. Accuracy is important.
2. Center one notch on the sleeve along the centerline of the gate leaf (see Figure 11). You can then align this centered notch with the punch mark on the splined shaft of the pinion as a reference in case you ever need to remove the shoe later.

**Caution:** NEVER weld the splined shaft of the pinion to anything.

Spot-weld the splined collar into place on the bottom of the shoe's U-shaped section. If you are using the shear-pin assembly, spot weld the splined collar to the bottom of the shear-pin assembly, and spot weld the top of the shear-pin assembly to the bottom of the shoe's U-shaped section. (You must still meet the two alignment requirements noted above even if you are using the shear-pin assembly.)

Next you must test the temporarily welded position of the sleeve. Fit the sleeve over the splined shaft with the U-shaped section aligned in the gate leaf's fully closed position. Verify that the axis of rotation falls through

the hinge(s), the pilot hole, and the center of the splined shaft.

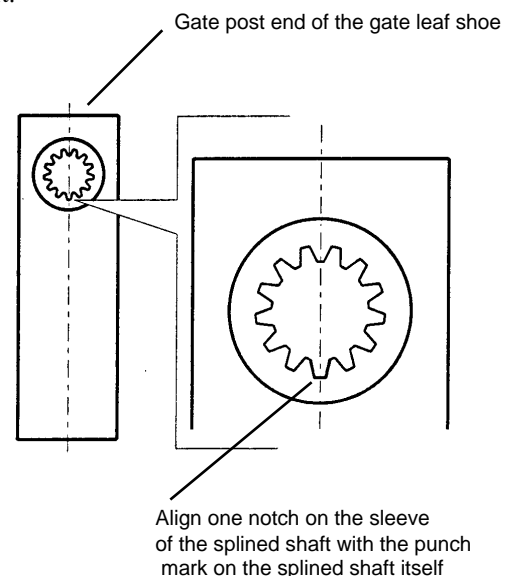

**Figure 11. Center one notch along the centerline of the gate leaf shoe and place over the punch mark on the splined shaft**

If the axis of rotation alignments are correct, then permanently weld the sleeve for the splined shaft to the bottom of the U-shaped section of the shoe.

Also, you now need to weld the pilot hole closed, and you need to weld the vertical section of the shoe to the U-shaped section of the shoe.

Lubricate the splined shaft with grease and place the finished gate leaf shoe assembly over the shaft in the closed position.

## Install the Gate Leaf

If you are not using the telescoping shear-pin assembly, install the gate leaf by placing its 90-deg corner into the gate leaf shoe and then installing the other gate hinge(s).

Next, very slowly open and close the gate leaf a few times to see if it moves smoothly and evenly through its entire path.

## Install the Operator in the Load Bearing Box

**Note:** The installation of the operator assumes you have installed the load bearing box and the gate leaf. Do *not* proceed with installing the operator until the load bearing box and gate leaf have been installed.

### Remove Covers

To install the 760 Operator (see Figure 12), first prepare the splined shaft in the mounting box by removing the pinion cover (Figure 13). To remove the pinion cover, remove the four bolts holding the cover.

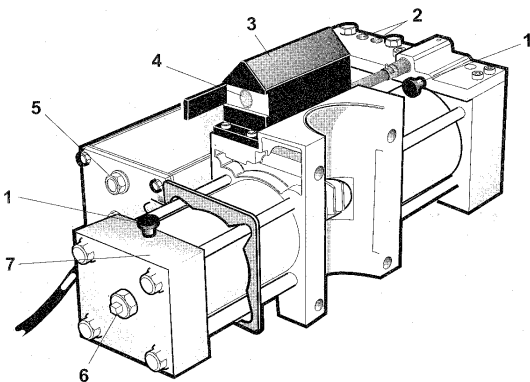

- 1 Bleed screw
- 2 Bypass valves
- 3 Manual Release
- 4 Release lock (optional)
- 5 Oil plug
- 6 Adjustment screw for the beginning of the braking phase
- 7 Deceleration adjustment screw

**Figure 12. The parts of the 760 Operator with soft stop**

Next, remove the plugs holding the rack cover to the 760 Operator (see Figure 14). Be sure to keep track of the plugs and the rack and pinion covers in case you ever need to remove the operator for repair.

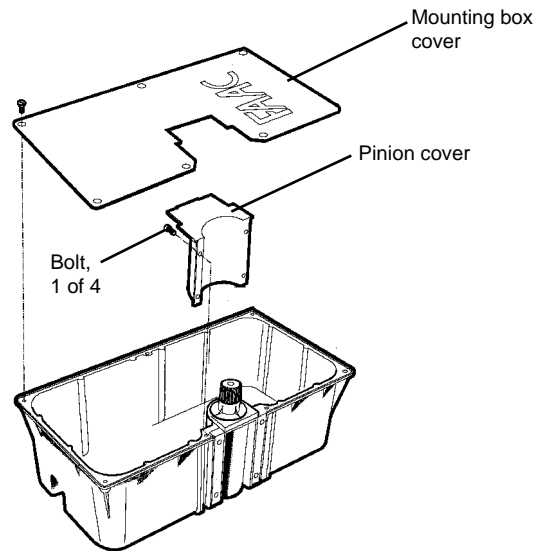

**Figure 13. Remove the pinion cover by removing the snap-on bolts that hold it to the pinion assembly**

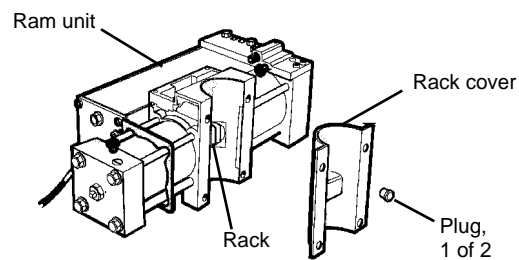

**Figure 14. Remove the rack cover by removing the plugs that hold it on the 760 Operator**

## Position the Gate Leaf

The 760 Operator is shipped to you with the hydraulic ram in the half-opened position. This means that before you mate the pinion and the rack, you need to open your gate leaf to the half opened position to assure the maximum travel for your gate leaf in the opening and closing directions.

The greater the arc of swing in your gate leaf (the closer you are to the maximum swing of 148 degrees), the more important it is that you be *exact* in opening the gate to the half-opened position. If necessary, measure the distance.

If your gate leaf opens less than 90 deg, you can have 10 deg of braking in only one direction (call us for details). To assure any braking whatsoever, you must compute the opening distance for your gate leaf to use before you mate the rack and pinion. For braking on closing, determine what 3/4 the length of your gate leaf is, and

open the gate leaf that distance from the closed position (see Figure 15).

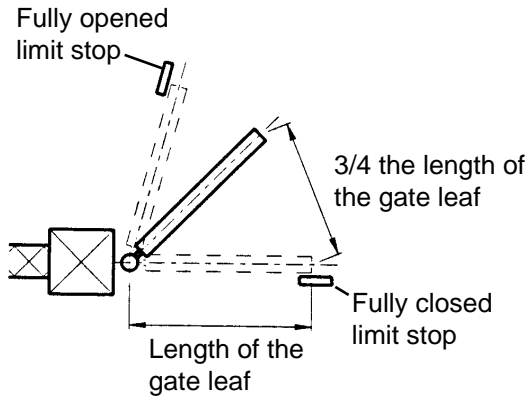

**Figure 15. On a gate leaf that opens less than 90 deg, properly position the gate leaf before installing the 760 Operator**

## Mount the Operator

Once the gate leaf is in the proper partially opened position, install two lock washers and the two extraordinary, long-headed bolts through the two holes in the bottom of the 760 Operator (see Figure 16). Mate the rack in the operator to the pinion in the mounting box. Next, insert the two bolts through the top of the operator and into the mounting box (see Figure 16). Tighten all four bolts securely.

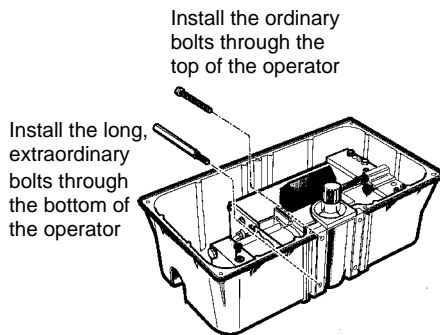

**Figure 16. Anchor the operator to the mounting box and pinion assembly**

## Adjust the Pressures for the Operator(s)

**WARNING!** You **must decrease** the pressures of the gate's opening and closing momentum **completely** before you operate the gate electrically. The pressure valves are not preset at the factory and may operate the gate leaf with enough force to endanger people and seriously damage the gate leaf itself.

The green and red screws on the top of the oil reservoir of the 760 Operator are the bypass valve adjustments that control the force of the gate leaf's opening and closing momentum (see Figure 17). For either valve, turning the screw clockwise increases the pressure and turning it counterclockwise decreases the pressure.

Which screw controls the opening thrust of the gate and which the closing thrust depends on the orientation of the unit in your installation site. The green screw always controls the clockwise rotation of the splined shaft, and the red screw always controls the counterclockwise rotation of the splined shaft.

Before you operate the gate for the first time, you must completely decrease the pressures for both opening and closing. Turn both screws counter-clockwise all the way. Later you will adjust these pressures.

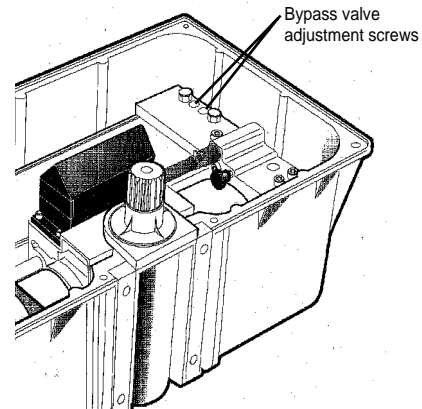

**Figure 17. Decrease the pressures controlled by the bypass valve screws completely before you operate the gate electrically**

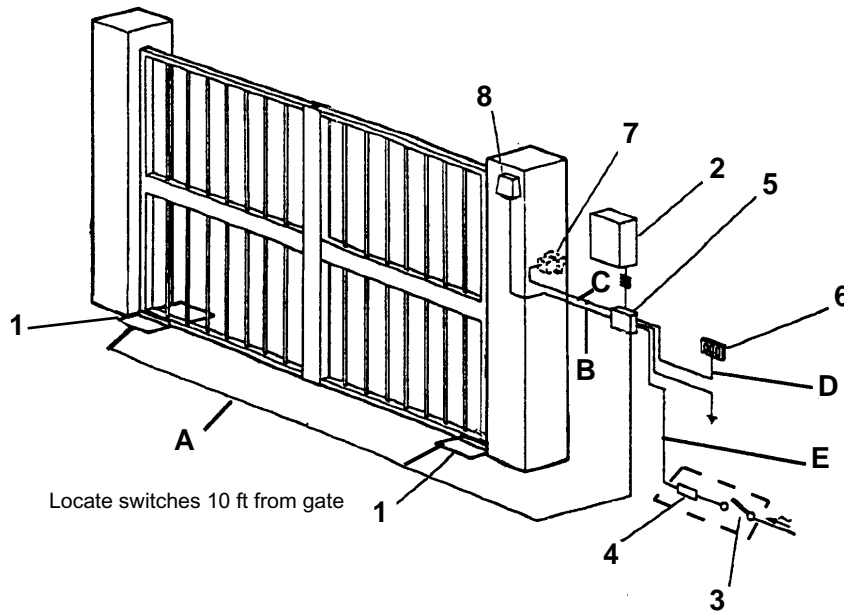

Locate switches 10 ft from gate

#### Gate System Parts

- 1 760 Operator in mounting box
- 2 760 Control Panel box
- 3 Main power switch
- 4 Circuit breaker
- 5 Main junction box
- 6 Switch for 760 Operator
- 7 Switch for 760 Operator
- 8 Radio receiver

#### Wire Gauges for Given Power Source Voltage

- 220 VAC
- A 4 X 14 AWG
  - B 3 X 18 AWG
  - C 5 X 18 AWG
  - D 5 X 18 AWG
  - E 4 X 14 AWG up to 414 ft (126 m)

Figure 18. Typical layout of gate system with 760 Operators

## Install the 450 MPS Control Panel

Locate the control panel in a convenient position, considering the movement of the gate. Figure 7 shows a basic layout for a two-leaf gate with two 760 Operators.

Installing the control panel consists of the following general steps:

- Connect the main power supply
- Connect the operator(s) to the control panel
- Check the direction of the motor's rotation
- Connect other devices
- Set operating controls

The installer is responsible for grounding the operator systems, for providing the main power breaker switch, and for making sure that the entire gate system meets all applicable electrical codes.

Follow the instructions that follow to install the 450 MPS control panel for the 760 Operator.

## Connect the Main Power Supply

**WARNING!** Turn the main power off before you make any electrical connections or set any switches inside the control panel box.

Wire the main power supply to control panel terminals in block J1 (see Figures 20 and 21). The installer is responsible for insuring that a separate, grounded circuit protected by a circuit breaker is between the control panel and the main power supply. All wiring should conform to applicable electrical codes, and all wiring and fittings should be weatherproof and/or suitable for burial.

Connect the ground to the grounding terminal in block J1 and connect the power wires to the terminals labeled N (neutral) and L (line).

**Caution:** The operators are grounded only by the grounded circuit the installer provides.

**Note:** For a 230v system, a neutral is not needed. Connect one 115v line to the L (line terminal) and a second 115v line to the N (neutral terminal).



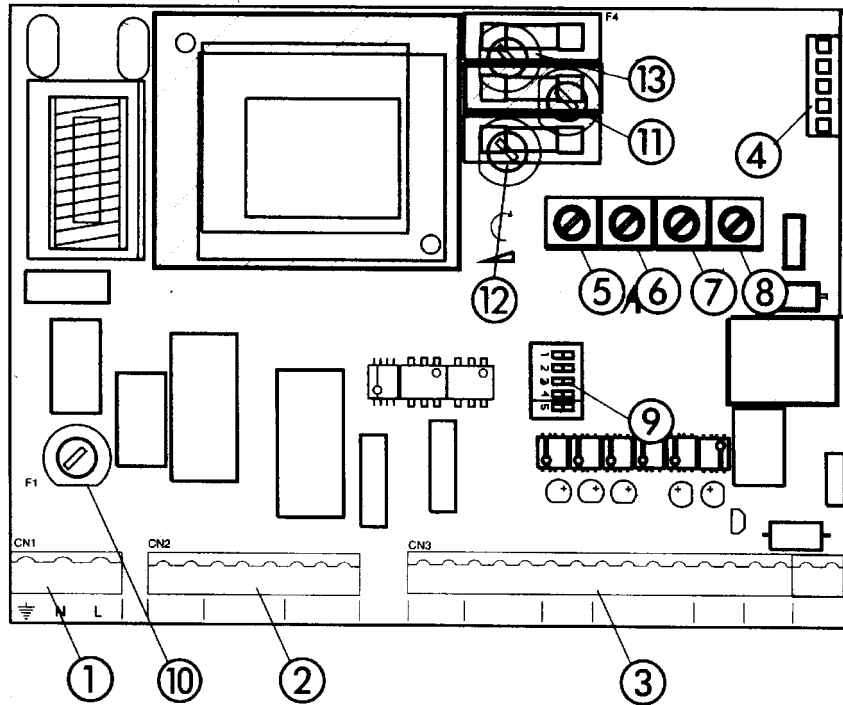

- 1 J1 terminal block for main power supply
- 2 J2 terminal block for connecting the operator(s)
- 3 J3 terminal block for low-voltage accessories
- 4 J4 quick connector port
- 5 Pressure adjustment potentiometer
- 6 Pause time potentiometer
- 7 Potentiometer for adjusting open/close time

- 8 Leaf delay potentiometer
- 9 DIP switch assembly

Fuses	220 VAC	115 VAC
10 F1, Main power	5 A	10 A
11 F2, Accessories	800 mA	800 mA
12 F3, Electric lock	1.6 A	1.6 A
13 F4, Microprocessor	250 mA	250 mA

**Figure 19. The 450 MPS control panel**

## Connect the Operator(s) to the Control Panel

**WARNING!** Turn the main power off before you make any electrical connections or set any switches inside the control panel box.

### Using a Junction Box

Connecting your operator(s) to the control panel may require the use of one or more junction boxes. Whether you need 0, 1, or 2 U.L. Listed junction boxes depends on your gate design.

If any operator is more than 2 ft away from the U.L. Listed control panel enclosure, the connection must be made inside a junction box. Use a U. L. Listed cord grip where the operator cord enters the junction box; use conduit between the junction box and the enclosure.

**Caution:** The control panel will not operate without an operator connected to terminals 3, 4, and 5.

If your gate system has one operator, connect the capacitor and the red and black (or brown and black) wires from your operator to the terminals 3 and 5 in block J2. Connect the white (or blue) wire from the operator to terminal 4.

**Note:** If you want to delay the closing of one gate leaf in a two-leaf gate design, be sure to connect its operator to Motor 1 (terminals 3, 4, and 5).

If your gate system has two operators, connect the second operator to terminals 6, 7, and 8 in block J2. Connect the second capacitor and the red and black (or brown and black) wires to terminals 6 and 8, and connect the white (or blue) wire from the operator to terminal 7.

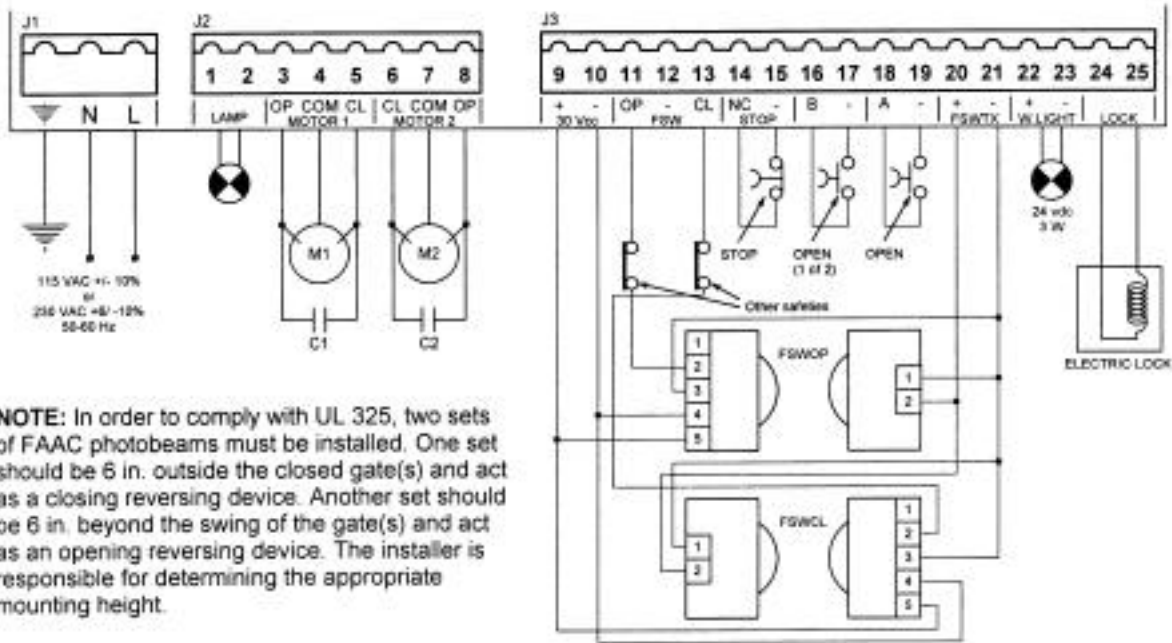

Figure 20. The terminal strip wiring of the 450 MPS with photobeams

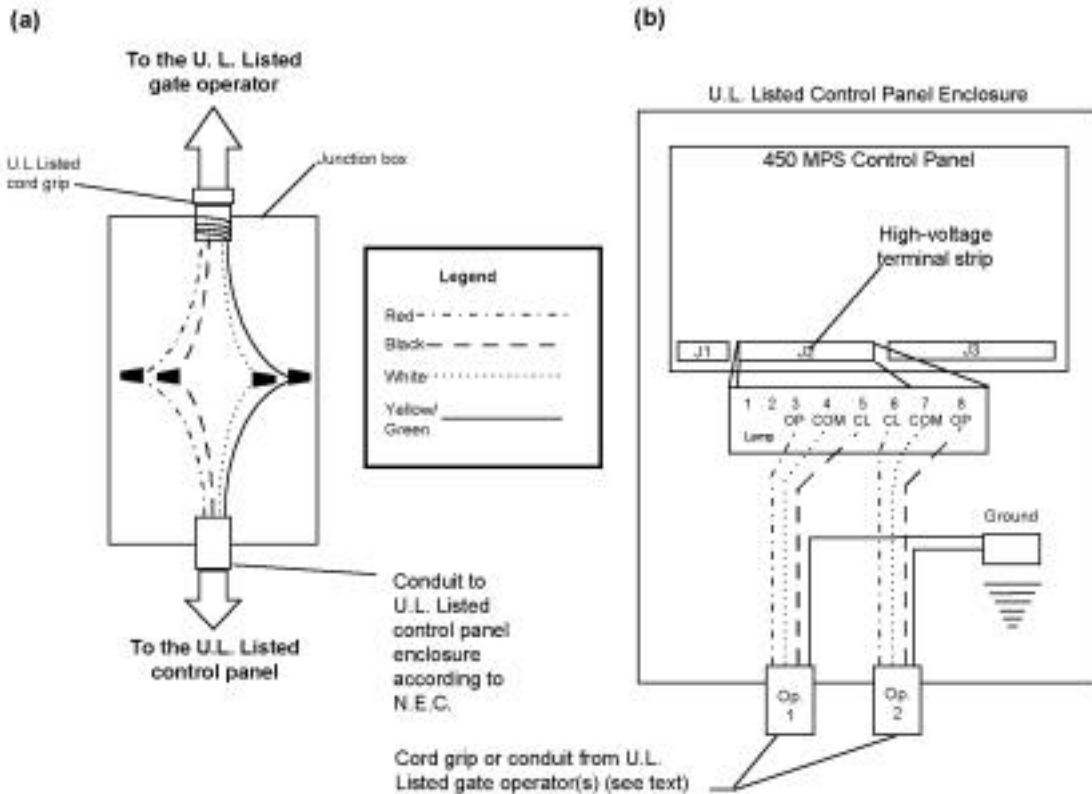

Figure 21. Wiring detail (a) inside the junction box and (b) from the junction box or operator to the high-voltage terminal strip on the 450 MPS control panel

## Check the Motor's Direction of Rotation

After you have connected the main power supply, the capacitor(s), and the operator(s) to the control panel, you need to check the direction of rotation for each operator motor in your gate design.

To check a motor's direction of rotation, you must have three closed circuits on terminal block J3. Install one circuit between terminals 11 and 21, another circuit between 13 and 21, and another circuit (or stop device) between terminal 14 and 15.

You cannot check the motor's direction of rotation without these circuits (jumpers) or the accessories. When properly prepared for testing, the LEDs DL3, DL4, and DL5 should be illuminated.

**WARNING!** Running the operator—even for testing purposes—without a connected reversing device is potentially dangerous. Do not place yourself within the path of the moving gate during your test.

You also need to install a normally open activation device across terminals 18 and 19.

Disengage the operator(s) with the Manual Release key, and open the gate by hand about halfway (See Figure 3).

Next, engage the operator(s) with the Manual Release key so that you can check the rotation of the motor(s).

Turn on the main power and send an activating signal to the operator(s). The gate leaf (or leaves) should open. If a gate leaf closes, then you need to turn off the main power and reverse the connection of the red and black (or brown and black) wires on terminal block J2 for the operator controlling that leaf. Then you need to recheck the rotation direction again.

If your gate system has two operators, be sure the motor of each rotates in the correct direction.

After having completed your test of the motor's direction of rotation, replace any test circuits you installed (between terminals 11 and 21, between 13 and 21, and between 14 and 15) with the proper reversing and stop devices. The instructions for installing such accessories follow.

## Connect Other Devices

**WARNING!** Turn the main power off before you make any electrical connections or set any switches inside the control panel box.

Now you can connect additional reversing and activating devices to the control panel. Refer to Figure 19 for the general control panel layout, and refer to Figure 20 for the layout of the terminal strip.

**Power Supply for Accessories:** You can access a 30 VDC output for supplying power to accessories that require DC voltage through terminals 9 and 10 (located above the label *30 Vcc*) on terminal block J3. In most cases, this source can be used to power 24 VDC accessories.

**Note:** The 450 MPS control panel allows a maximum accessory load of 800 mA.

**Reversing Devices:** Reversing devices include photobeams, inductive loops, and so forth. All of the reversing devices should have contacts of the normally closed (N.C.) type. Where you connect a device depends on whether you want the device to operate during opening or during closing.

**Note:** UL **does not** recognize the FAAC system with loop detectors or safety edges. FAAC photobeams must be used to comply with UL 325.

**Caution:** Failure of a reversing device that operates during opening, causes a gate to lock in the closed position and requires the use of the Manual Release key.

To wire photobeams, refer to Figure 9 (see FSWOP for opening photobeams, and FSWCL for closing photocells—connect the photobeams exactly as shown). See Figure 22 for the wiring of a variety of common accessories. In either case, if you have multiple devices, wire them in series.

**Activating Devices:** The activating devices for your gate must have normally open (N.O.) contacts. Connect all devices to terminals 18 and 19. If you have a dual gate and want a particular activating device to open only one leaf, connect it to terminals 16 and 17.

**Decoder Card:** If you are installing a FAAC radio receiver, a Digicard magnetic card reader, or a Digikey keypad, use the quick-fit connector J4 for the radio receiver or the DS (formerly the MD01) decoder card (see Figure 19).

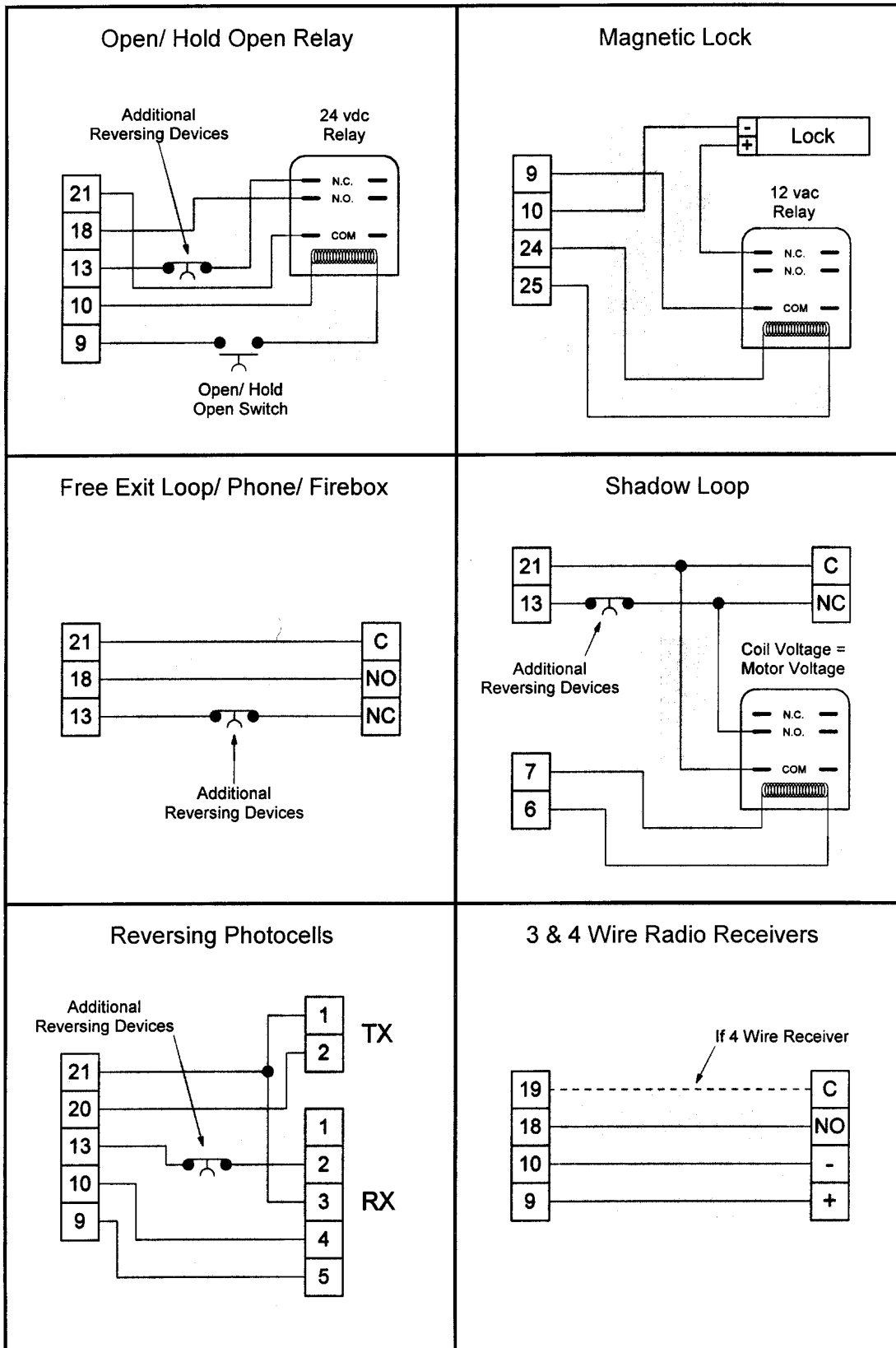

Figure 22. Common accessories wired to 450 MPS.

**Note:** If you are using both a receiver and a decoder, hard wire the decoder and plug the receiver in.

**Open/Hold Open Device:** To open and hold open the gate, an Open/Hold Open device must make a set of contacts across terminals 18 and 21 and must break a set of contacts between terminals 13 and 21. See Figure 22 for more detail.

**Stop Button:** The stop button you install must have normally closed (N.C.) contacts. Multiple stop buttons must be wired in series. Connect your stop device between terminals 14 and 15.

**The LED Indicators:** The five light-emitting diodes (LEDs) on the control panel can be used to check for the proper functioning of the devices you attach to the control panel. The LED lights are on whenever the contacts are closed across each of the respective terminals.

DL1 and DL2 should illuminate only when an activating signal is sent for 2 and 1 gate leaves, respectively. DL3 should be illuminated except when the stop button is pressed. DL4 and DL5 should be illuminated except when the reversing devices for opening and closing, respectively, are triggered. Use the LEDs and the table below to determine if the accessory devices you have installed are operating properly.

LED	On	Off
DL1, Open 2 leaves	Command active	Command inactive
DL2, Open 1 leaf	Command active	Command inactive
DL3, Stop	Command not active	Command active
DL4, FTSW Open	Opening reversing devices not triggered	Opening reversing device triggered
DL5, FTSW Close	Closing reversing devices not triggered	Closing reversing device triggered

**Electric Lock:** Connect your lock to the terminals 24 and 25. The terminals provide 12 VAC that pulses for 4 seconds whenever the gate starts to open. An electric lock can make use of the reversing stroke function controlled by DIP switch 5. A reversing stroke is a short closing phase that allows the electric lock time to disengage itself before the operator starts its opening. Turn DIP switch 5 on only if necessary for your lock to function correctly.

See Figure 22 for the wiring of a magnetic locking device.

**Warning Light:** Connect a warning light to terminals 22 and 23 in the group labeled *W.LIGHT* in terminal block J3. The terminals provide an output voltage of 30 VDC, maximum power 3 Watts. This output voltage will power most 24 VDC warning lights.

**Note:** The behavior of the warning light varies according to the logic you have set.

**Logics A, S, E, EP, and B:** The warning light is on steadily during opening and the pause phase. During closing, the light flashes.

**Logic C:** The warning light is on steadily during opening and flashes during closing.

## Set Operating Controls

**WARNING!** Turn off the main power before you make any electrical connections or set any switches inside the control panel box.

You need to set DIP switches and adjust the potentiometers on the control panel for your gate's operation. The 450 MPS Control Panel has 5 DIP switches and 4 potentiometers that control a wide range of functions.

### Set DIP Switches

**Switches 1, 2, and 3 (Operating Logic):** The 450 MPS Control Panel offers six operating modes: A, S, E, EP, B, and C.

Refer to the operating logic tables earlier in these instructions for more detail about the logical modes available on the 450 MPS control panel.

Switches 1, 2, and 3 control the operating logic according to the following table:

Logic	Switch		
	1	2	3
A	on	off	on
S	on	off	off
E	off	on	off
EP	on	on	off
B	on	on	on
C	off	off	on

**Switch 4 (Reversing Device Behavior on Closing):** Refer to the operating logic tables earlier in this manual and to the chart below for how to set DIP switch 4.

Gate Behavior During Closing	Switch 4
Gate immediately reverses its direction when a reversing device is triggered	off
Gate stops and reverse its direction when reversing device is no longer triggered	on

**Switch 5 (Reversing Stroke):** Sometimes electric locks require a reversing stroke to disengage the lock. If your gate does not always open because your lock is hanging up, you may want to activate the reversing stroke.

Reversing Stroke	Switch 5
Not activated	off
Activated	on

### Adjust the Potentiometers

The four potentiometers control the torque, the pause time, the opening/closing time of operation, and the leaf delay for closing.

**Torque:** The torque potentiometer on the 450 MPS **must** be turned all the way clockwise for the 760 Operator. The potentiometer controls voltage to the operator. It is used for the FAAC model 412, a screw drive operator. The torque potentiometer **cannot** be used to adjust the operator's hydraulic operating pressures.

**Caution:** Failure to turn the torque potentiometer to maximum in the clockwise direction jeopardizes the life of the motor of your operator.

**WARNING!** Adjust the operating pressure on the 400 Operator only by means of the hydraulic bypass valve screws. See pages 15 and 22.

**Pause Time:** The pause (time gate stays open) can be adjusted from 0 to 240 seconds. Turn the potentiometer clockwise to increase the pause time and counterclockwise to decrease the pause time.

**Opening/Closing Time:** The opening/closing time is adjustable from 10 to 62 seconds. The approximate opening/closing time for a 90-degree opening varies from 12 to 17 seconds, depending on the model. Turn the potentiometer clockwise to increase the time and counterclockwise to decrease the time.

For optimal operation, set the time so that the motor remains active for a couple of seconds after the leaf has reached its positive stop for opening and for closing.

**Leaf Delay:** You may choose to delay one leaf on closing for overlapping gate leaves. Be sure the operator on the leaf for delayed closing is connected to Motor 1. On opening, the leaf connected to Motor 2 is delayed 2.5 sec.

**Note:** You cannot adjust this opening delay of the operator connected to Motor 2. However, you can turn off the delay by closing the jumper labeled "Open Leaf Delay Disable" on the 450 MPS.

The closing leaf-delay time is adjustable from 0 to 28 seconds. Turn the potentiometer clockwise to increase the time and counterclockwise to decrease the time.

**Note:** In one-leaf gate designs, be sure to set the potentiometer for leaf delay to its minimum (0 seconds).

**Note:** If the opening/closing time is set at less than the leaf delay time, the delayed leaf closes at the end of the closing time.

### Fine-tune the Bypass Valve Pressures

The pressure a gate leaf applies to an obstacle in its path is determined by the bypass valve adjustment. The safety standards of FAAC International, Inc., recommend that the gate should stop when it meets with a force of more than 33 lb (15 kg).

**WARNING!** The pressure valves may operate the gate leaf with enough force to endanger people and seriously damage the gate leaf itself. Increase the pressures in small increments (1/4 turn), and set the pressure adjustments at the *minimum* level necessary for the gate's operation.

Which bypass valve screw controls the opening thrust of the gate and which the closing thrust depends on the orientation of the unit in your installation site. The green screw always controls the clockwise rotation of the splined shaft, and the red screw always controls the counterclockwise rotation of the splined shaft.

Fine tune the pressures for both opening and closing after you have installed the control panel for the 760 Operator. Set the pressures at the *minimum* necessary to open or close the gate leaf.

**Note:** The red and green screws are not a speed adjustment. The motor speed and pump displacement are constant.

**Warning!** Do not increase the pressure adjustments excessively in an attempt to speed up the gate. Doing so can increase the risk of serious injury.

## Adjust the Beginning of the Braking Phase

You need to adjust the start of the braking phase for opening and closing. You adjust the braking to no more than 10 deg before fully closed and fully opened. Figure 23 shows the location of the adjustment screws for the beginning of the braking phase.

**Note:** The 760 Operator ships from the factory with the braking phase adjustment screws turned all the way clock-wise. This position of the screws corresponds to *no* braking phase whatsoever.

If you have a CBAC model with hydraulic locking, you first need to use the Manual Release to disengage hydraulic operation of the 760 Operator before you adjust the screws for defining the beginning of the braking phase.

To adjust the start of the braking phase, first make sure the deceleration adjustment screws are not tightened completely. Unscrew them at least a couple of turns (see Figure 24).

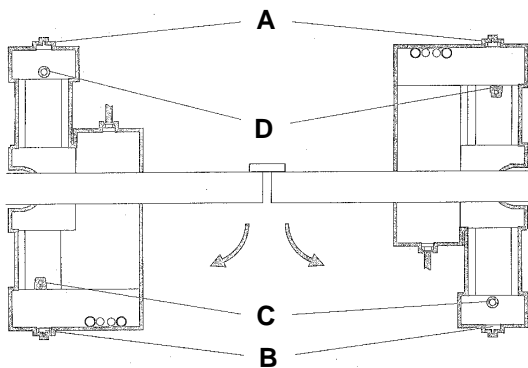

- A Brake adjustment bolt for closing
- B Brake adjustment bolt for opening
- C Opening bleed screw on CR models
- D Closing bleed screw on CR models

**Figure 23. The location of the brake adjustment bolts for the beginning of the braking phase and the bleed screws.**

Then, place the gate leaf in the fully closed position against the closed limit stop. Next loosen the brass lock nut from the brake adjustment bolt for closing. Then, using an 8mm open end wrench, turn the square-headed brake adjustment bolt for closing counterclockwise until the gate leaf begins to move (see Fig. 12 or 23). Then

turn the bolt one half of a turn clockwise and retighten the brass lock nut.

Manually move the gate leaf to the fully opened position against the opened limit stop. Loosen the brass lock nut for the opening brake adjustment bolt. Next, turn the square-headed opening brake adjustment bolt counterclockwise until the gate leaf starts moving. Then turn the bolt one half of a turn clockwise and retighten the lock nut.

**Note:** If your gate leaf opens less than 90 deg, setting the beginning of the braking phase may have no effect on the gate leaf. The only way to adjust the beginning of the braking phase is with the position of the gate leaf and the rack when you mate the rack and pinion. Call us for details.

**Note:** If you wish the braking of the operator in the opening or closing direction to start at less than 10 deg, turn the corresponding bolt another couple of turns. There is no way to begin braking at more than 10 deg.

## Adjust the Braking Intensity

Figure 12 shows you the location of one of the deceleration adjustment screws; the other is similarly located on the other end of the operator. Figure 24 shows that you turn the adjustment screws clockwise to increase the intensity of the braking and counterclockwise to reduce the intensity of the braking.

## Assemble and Install the Manual Release

The parts for the Manual Release are shipped in the shrink-wrapped package with other small parts.

To assemble the Manual Release, lay open the black plastic Manual Release housing so that the FAAC logo faces downward. You need to place in the ribbing on one side of the black plastic the brass gear assembly and the plastic gear assembly. The gears themselves for both parts sit within the middle of the housing and engage one another (see Figure 25).

Then you can gently fold the black plastic housing around the gear assemblies. The black plastic housing should snap shut if you have the access doors to the key holes out of the way.

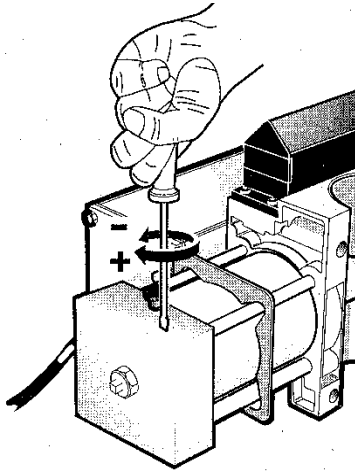

**Figure 24. Turn the adjustment screw clockwise to increase the braking intensity and counter-clockwise to decrease the braking intensity**

The brass rod that extends from the plastic gear assembly and out of the black plastic housing has a 6-mm hex head on the visible end. You need to slide this hex head into the brass fitting of the 760 Operator that is located on the same end as the bypass valve adjustment screws (see Figure 29).

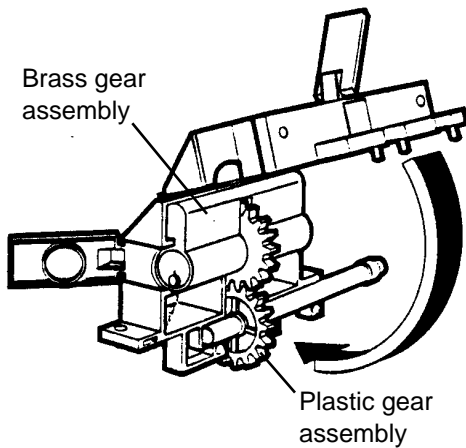

**Figure 25. Assemble the Manual Release mechanism**

Once the head is seated, the rest of the Manual Release assembly should fit into place on the top of the 760 Operator. Use the four screws in the parts package to hold the Manual Release housing in place.

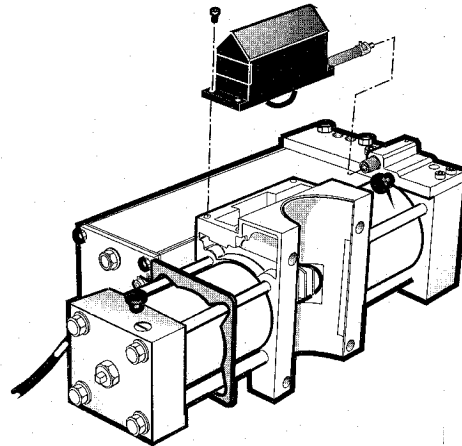

**Figure 26. Install the Manual Release mechanism**



# Installing an Extension Arm

Some gate installations do not meet the geometrical constraints shown in Figure 4. In those situations, the 760 Extension Arm option can be used to install a 760 operator.

The geometrical constraint for using the 760 Extension Arm is that the center of the splined shaft on the mounting box *must* be within 6 in. (15.25 cm) of the axis of rotation of the gate leaf.

**WARNING!** The farther away the splined shaft is from the gate's axis of rotation, the greater the risk of danger from pinch points.

Install the mounting box so that the splined shaft is as near as possible to the gate's rotation axis and is directly beneath the center of the fully closed gate leaf.

You need to position the extension collar (see Figure 27) so that it smoothly slides within the extension U from the fully closed to the fully opened position. Note that the position of the extension collar is affected by the overlap of the extension bar and extension U.

Attach the 760 extension collar to the bottom of the gate leaf with a 7/16 in. bolt.

Weld together the extension bar and extension U according to Figure 30.

**Caution:** Do not weld anything to or on the inside of the sleeve of the splined shaft.

Next, weld the outside of the sleeve for the splined shaft solidly to the inside of the hole in the end of the extension bar.

Follow the rest of the instructions for installing the 760 Operator. With an extension arm, you need not worry about installing a gate leaf shoe nor about installing the gate leaf in the shoe. Instead, you will install one end of the welded extension arm over the splined shaft and the other end around the extension collar.

In addition, you will need to provide a washer beneath the extension collar to keep the extension U from falling off the collar. You also need to shield any pinch points around the extension arm for safe operation.

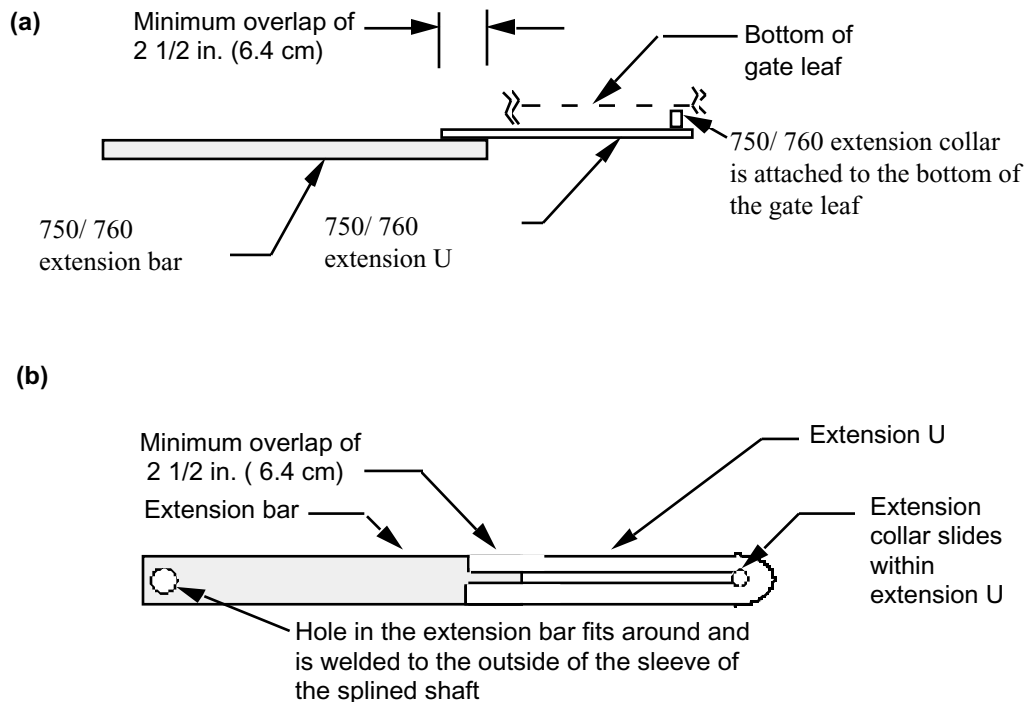

Figure 27. The 760 Extension Arm, (a) side view and (b) top view

# Maintenance

## The 760 Operator

The FAAC recommended maintenance schedule varies according to the frequency of use of the operators, whether lightly used operators (once or twice an hour) or heavily used operators (many cycles per hour). Operators used in a humid/ salt air climate should follow the heavy duty use schedule.

### Check the oil.

To check the oil level correctly, remove the oil filler cap on the 760 Operator. The oil level should be at or just below the opening of the filler hole.

Light duty use: check once per year

Heavy duty use: check every 6 mo

### Change the oil.

Changing the oil completely in the hydraulic system of the 760 Operator requires removing the 760 Operator from its installed position. (Do not remove the gate or the mounting box with the pinion and splined shaft.) Drain the oil out the oil filler hole before filling the operator to just below the hole. Remount the operator.

Light duty use: change every 4 yr

Heavy duty use: change every 2 yr

### Check the pressure settings.

Light duty use: check once per year

Heavy duty use: check every 6 mo

### Rack and Pinion

When you remove the 760 Operator from the mounting box to change the hydraulic oil, grease the rack and the pinion.

Light duty use: every 4 yr

Heavy duty use: every 2 yr

### Bleed the Hydraulic System

The 760 Operator has had all air bled from its hydraulic system when it is shipped to you. The only time it should be necessary to bleed the 760 Operator is after you repair the hydraulic system.

To bleed the hydraulic system of air that might cause bouncy or jerky operation do the following:

1. Remove the access cover to the mounting box.
2. Give an open signal to the gate.
3. While the gate is opening unscrew the opening bleed screw (see Figure 23).
4. Wait until only clean, bubble-free oil flows out the bleed screw.
5. Tighten the opening bleed screw.
6. Give a closing signal to the gate.
7. While the gate is closing, unscrew the closing bleed screw.
8. Wait until only clean, bubble-free oil flows out the bleed screw.
9. Tighten the closing bleed screw.

Repeat steps 1–8 again after five minutes if necessary. Then be sure to slowly fill the oil level to just below the filler hole.

## The Control Panel

The control panel requires no maintenance.

# Troubleshooting

**WARNING!** Before you do any work on the control panel, be sure to turn off the main power.

**Problem: The gate does not respond to an activating signal.**

**Solution:**

Verify that you have correctly wired the operator to the control panel.

Verify that the LED DL3 is on. If it is not illuminated, then check the fuses on your control panel.

If the LED DL3 is not illuminated and your fuses are okay, then the stopping device is being triggered and is preventing the gate from responding to your signal. If you have no stopping device installed, then be sure you have installed a jumper across the appropriate terminals.

Verify that your activating device works properly. Either DL1 or DL2 (depending on your gate design) should illuminate when you signal the gate to close (or open) and LED DL3 should be on. If either DL1 or DL2 does not illuminate when you signal the gate, then the problem may be in your activating device. Short across the appropriate terminals. If the short causes the gate to close (or open), then the problem is in the activating device. Repair or replace the device.

**Problem: The radio controlled opener does not open the gate.**

**Solution:**

Check the light on the front of the remote transmitter. It should illuminate when you signal the gate. If it does not illuminate and if the batteries are okay, repair or replace the transmitter.

Verify that the wiring is correct for the radio controlled device and the antenna.

Check DL1 and DL2. One should illuminate when the transmitter button is pressed.

Determine if the fault is in the receiver by temporarily connecting a push button device across the appropriate terminals. If such a push button device opens the gate, repair or replace the receiver.

**Problem: The gate doesn't open (or close) though the motors are running.**

**Solution:**

Make sure that the motor is running in the right direction, and make sure the Manual Release mechanism has fully engaged the hydraulic system.

Increase the bypass pressure in small  $\frac{1}{4}$  turn increments to see if the hydraulic system needs more pressure.

**Problem: The gate opens but does not close.**

**Solution:**

Make sure you have selected the desired operating mode.

Verify that the reversing devices are working properly. DL4 or DL5 should illuminate when a reversing device is triggered. If either does not illuminate, then one of your reversing devices is preventing the gate from responding to your signal. Check your reversing devices.

If no reversing devices are installed, make sure a circuit is installed between appropriate terminals.

If the motor is running, insure that the bypass valves are correctly adjusted. Increase the bypass pressure in small  $\frac{1}{4}$  turn increments to see if the hydraulic system needs more pressure.

**Problem: The gate does not fully open (or close).**

**Solution:**

Increase the bypass pressure(s) to see if the hydraulic system needs more pressure.

Check the operator's motor run time selection. You should set a time that is just longer than the rated speed of your model of operator. For example, because the 760 CBAC has a rated opening time of 17 sec, you should select a time that is just longer than the opening time.

Check to see that there are no obstructions in the path of the gate or that the hinges are not binding.

**Problem: The operator doesn't work smoothly and the gate jerks as it opens and closes.**

**Solution:**

Check the oil level in the operator.

Make sure the Manual Release mechanism has fully engaged the hydraulic operation of the operator.

Bleed the air from the hydraulic system by cycling the gate (opening and then closing) 10 times and pausing for a couple of minutes between cycles.

Make sure that a flexible gate leaf is not the problem. If the gate leaf flexes, then stiffen the gate or use a slower operator.

# Exploded View

# 760 Mounting Box & Splined Shaft

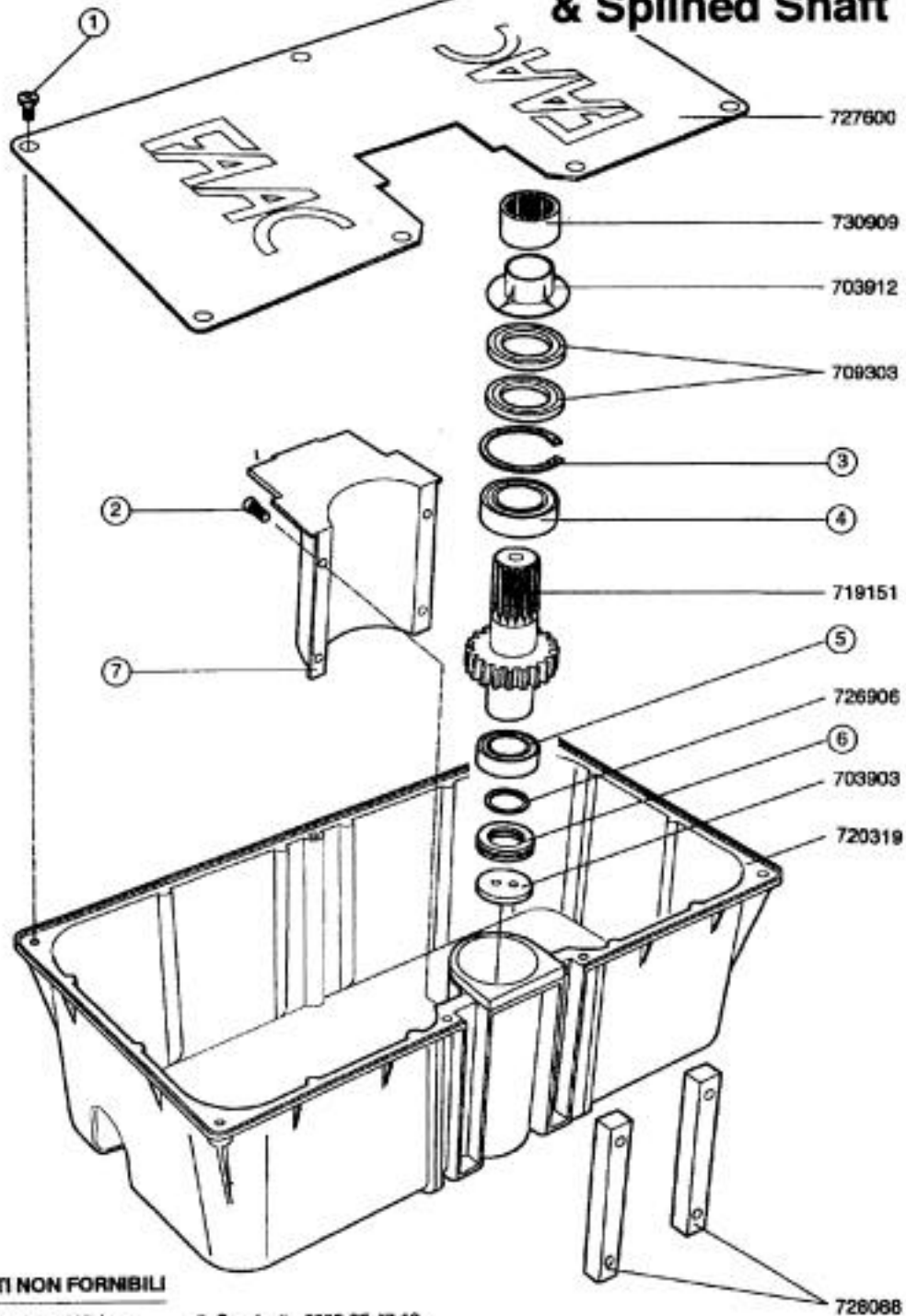

**rif. PARTI NON FORNIBILI**

1 TBIC 6x10 7687 Inox	5 Cuscinetto 6005-25-47-12
2 TCEI 8x35 5931 8G Z	6 Cuscinetto 51105
3 Seeger I55 7437	7 Staffa
4 Cuscinetto 6006-30-55-13	

0.0	06.95	00.00	
-----	-------	-------	--



# Exploded View — 760 CBAC-SB-SBS

UL strain relief  
kit (2167A\*):  
710914  
710915  
70902002  
703930

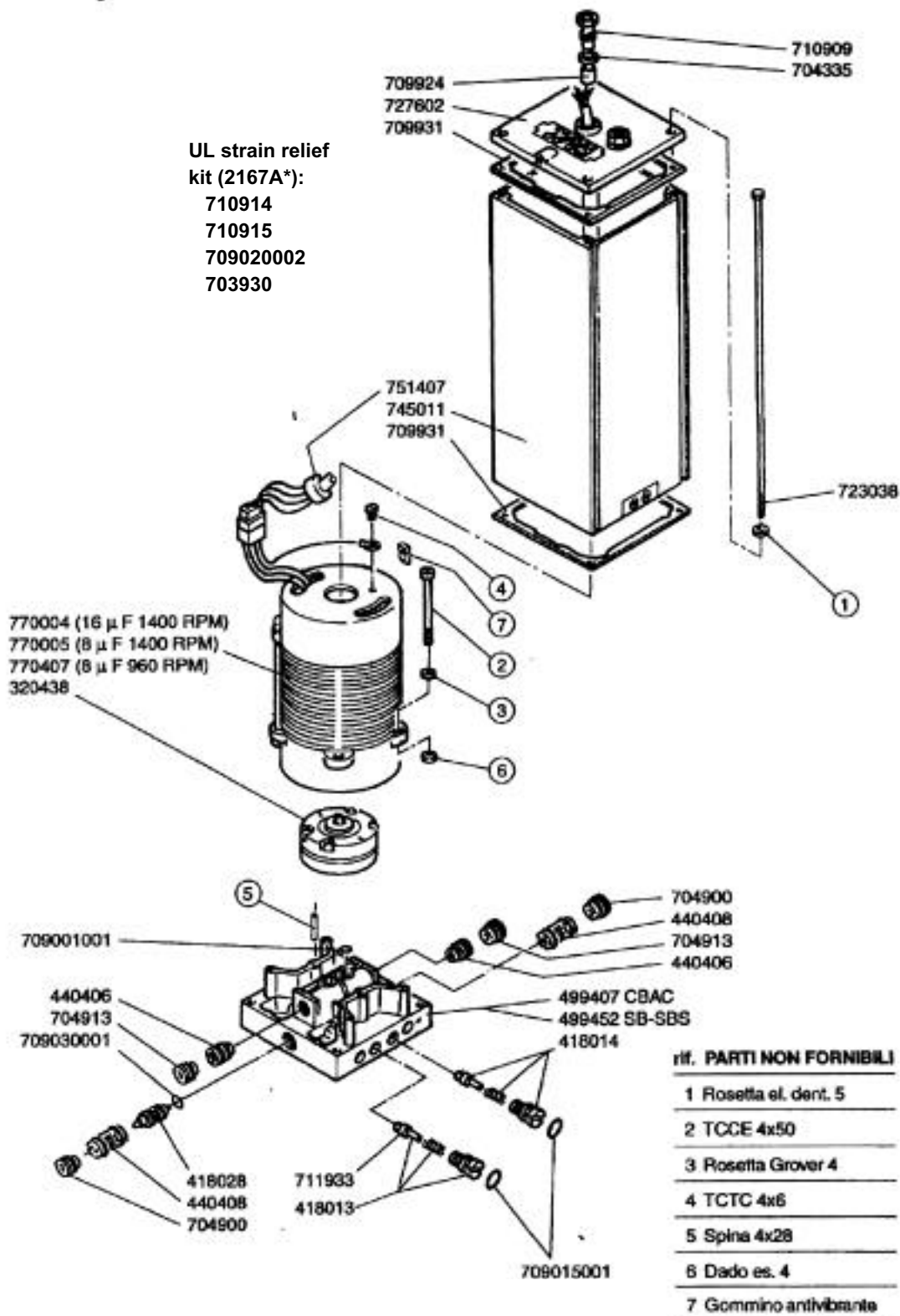

0.0	06.95	00.00	3.90.760.000
-----	-------	-------	--------------



# Exploded View

# 760 CR

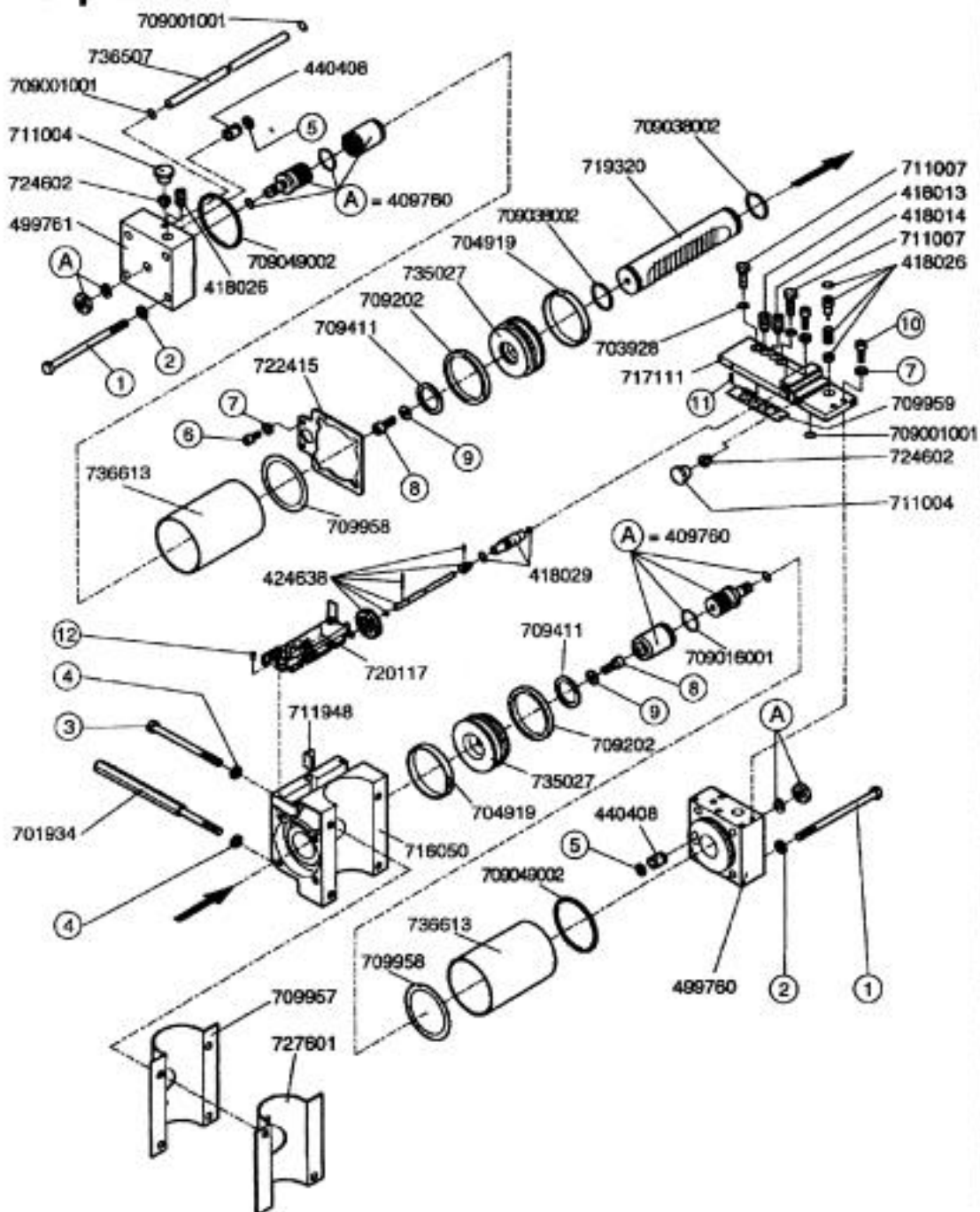

**rif. PARTI NON FORNIBILI**

1 TE 10X150 5737 8.8 Z	6 TCEI 6X12 5931 Z	11 Spina 3X12 UNI 1 707
2 Ros. Grover 10 7980 Z.G.	7 Ros. Grover 6 1751 Z	12 Autoform. 4X12 8112 PZ/TT Z
3 TE 8X110 5737 Z	8 TCEI 8120 5931 8.8 Z	
4 Ros. Grover 6 1751 Z	9 Rosetta 8 6592 R40 Z	
5 Seeger I 15 7437	10 TCEI 6X20 5931 Z	

0.0	06.95	00.00	3.90.760.000
-----	-------	-------	--------------

## Limited Warranty

*To the original purchaser only:* FAAC International, Inc., warrants, for twenty-four (24) months from the date of invoice, the gate operator systems and other related systems and equipment manufactured by FAAC S.p.A. and distributed by FAAC International, Inc., to be free from defects in material and workmanship under normal use and service for which it was intended *provided* it has been properly installed and operated. FAAC International, Inc.'s obligations under this warranty shall be limited to the repair or exchange of any part of parts manufactured by FAAC S.p.A. and distributed by FAAC International, Inc. Defective products must be returned to FAAC International, Inc., freight prepaid by purchaser, within the warranty period. Items returned will be repaired or replaced, at FAAC International, Inc.'s option, upon an examination of the product by FAAC International, Inc., which discloses, to the satisfaction of FAAC International, Inc., that the item is defective. FAAC International, Inc. will return the warranted item freight prepaid. The products manufactured by FAAC S.p.A. and distributed by FAAC International, Inc., are not warranted to meet the specific requirements, if any, of safety codes of any particular state, municipality, or other jurisdiction, and neither FAAC S.p.A. or FAAC International, Inc., assume any risk or liability whatsoever resulting from the use thereof, whether used singly or in combination with other machines or apparatus.

Any products and parts not manufactured by FAAC S.p.A. and distributed by FAAC International, Inc., will carry only the warranty, if any, of the manufacturer. This warranty shall not apply to any products or parts thereof which have been repaired or altered, without FAAC International, Inc.'s written consent, outside of FAAC International, Inc.'s workshop, or altered in any way so as, in the judgment of FAAC International, Inc., to affect adversely the stability or reliability of the product(s) or has been subject to misuse, negligence, or accident, or has not been operated in accordance with FAAC International, Inc.'s or FAAC S.p.A.'s instructions or has been operated under conditions more severe than, or otherwise exceeding, those set forth in the specifications for such product(s). Neither FAAC S.p.A. or FAAC International, Inc., shall be liable for any loss or damage whatsoever resulting, directly or indirectly, from the use or loss of use of the product(s). Without limiting the foregoing, this exclusion from liability embraces a purchaser's expenses for downtime or for making up downtime, damages for which the purchaser may be liable to other persons, damages to property, and injury to or death of any persons. Neither FAAC S.p.A. or FAAC International, Inc., assumes nor authorizes any person to assume for them any other liability in connection with the sale or use of the products of FAAC S.p.A. or FAAC International, Inc. The warranty herein above set forth shall not be deemed to cover maintenance parts, including, but not limited to, hydraulic oil, filters, or the like. No agreement to replace or repair shall constitute an admission by FAAC S.p.A. or FAAC International, Inc., of any legal responsibility to effect such replacement, to make such repair, or otherwise. This limited warranty extends only to wholesale customers who buy directly through FAAC International, Inc.'s normal distribution channels. FAAC International, Inc., does not warrant its products to end consumers. Consumers must inquire from their selling dealer as to the nature and extent of that dealer's warranty, if any.

**This warranty is expressly in lieu of all other warranties expressed or implied including the warranties of merchantability and fitness for use. This warranty shall not apply to products or any part thereof which have been subject to accident, negligence, alteration, abuse, or misuse or if damage was due to improper installation or use of improper power source, or if damage was caused by fire, flood, lightning, electrical power surge, explosion, wind storm, hail, aircraft or vehicles, vandalism, riot or civil commotion, or acts of God.**

**FAAC International, Inc.  
303 Lexington Avenue  
Cheyenne, WY 82007**

760 IM, 04/01