

November, 2003
450 MPS Control
Panel Installation
Instructions

450 MPS Control Panel: SUPPLEMENTAL INSTALLATION INSTRUCTIONS

FAAC

FAAC International, Inc.
303 Lexington Avenue
Cheyenne, WY 82007
www.faacusa.com

Note: These instructions supplement the installation manual for your operator. Be sure to review all safety information in the installation manual for your operator.

INSTALLING THE 450 MPS CONTROL PANEL

Locate the control panel in the most convenient position possible, considering the movement of the gate. Figure 7 shows a basic layout for a two-leaf gate with the 400 Operator.

Installing the control panel consists of the following general steps:

- Connecting the main power to the control panel
- Connecting the activating device
- Connecting the operator to the control panel
- Checking the direction of the motor's rotation
- Connecting other devices to the control panel
- Set operating modes

The installer is responsible for grounding the gate and operator systems, for providing the main power breaker switch, and for making sure that the entire gate system

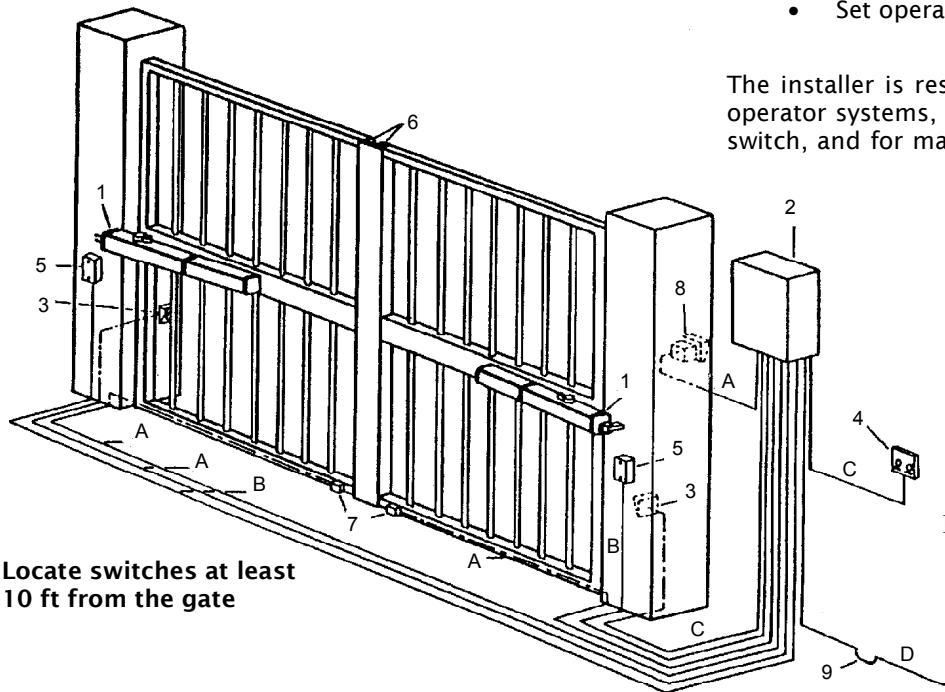

Locate switches at least 10 ft from the gate

Figure 7. The layout of a sample gate system

- 1 Operator
- 2 Control Panel
- 3 Photocell
- 4 Switch
- 5 Junction box (see text)
- 6 Reversing edges
- 7 Gate stops
- 8 Switch
- 9 Wiring to main circuit breaker

Wire Gauges for Given Voltage

	220 VAC	115 VAC
A	2 × 18 AWG	A 2 × 18 AWG
B	4 × 14 AWG	B 4 × 14 AWG
C	5 × 18 AWG	C 5 × 18 AWG
D	4 × 14 AWG up to 414 ft	D 3 × 14 AWG up to 130 ft 3 × 10 AWG up to 340 ft

CONNECT THE MAIN POWER SUPPLY

WARNING! Turn the main power off before you make any electrical connections or set any switches inside the control panel box.

Connect the ground to the grounding terminal in block J1 and connect the power wires to the terminals labeled N (neutral) and L (line).

Wire the main power supply to control panel terminals in block J1 (see Figures 8 and 9). The installer is responsible for insuring that a separate, grounded circuit protected by a circuit breaker is between the control panel and the main power supply. All wiring should conform to applicable electrical codes, and all wiring and fittings should be weatherproof and/or suitable for burial.

CAUTION: The operators are grounded only by the grounded circuit the installer provides.

NOTE: For a 230V system, a neutral is not needed. Connect one 115V line to the L (Line) and a second 115V line to the N (Neutral).

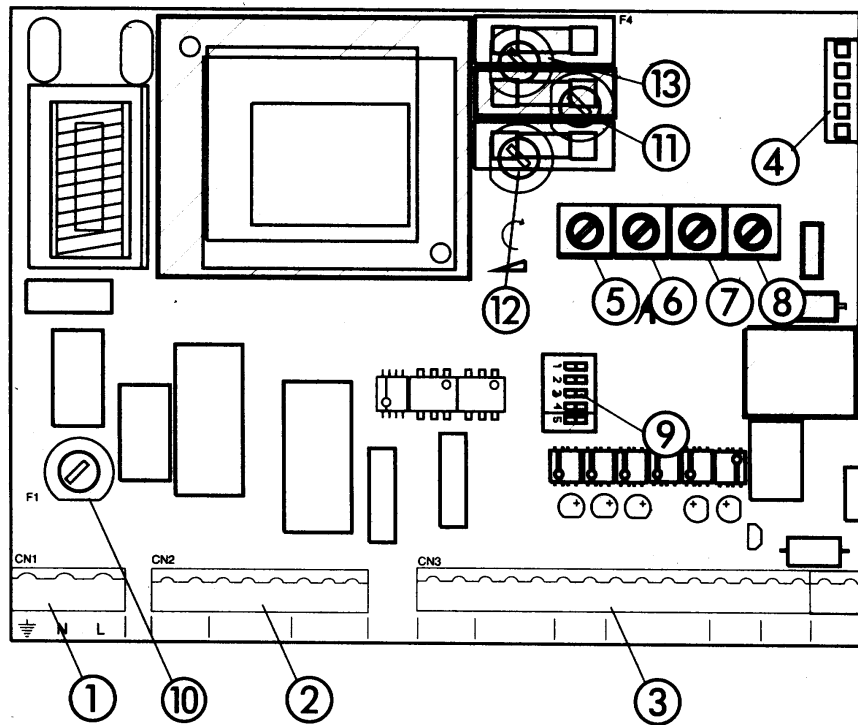
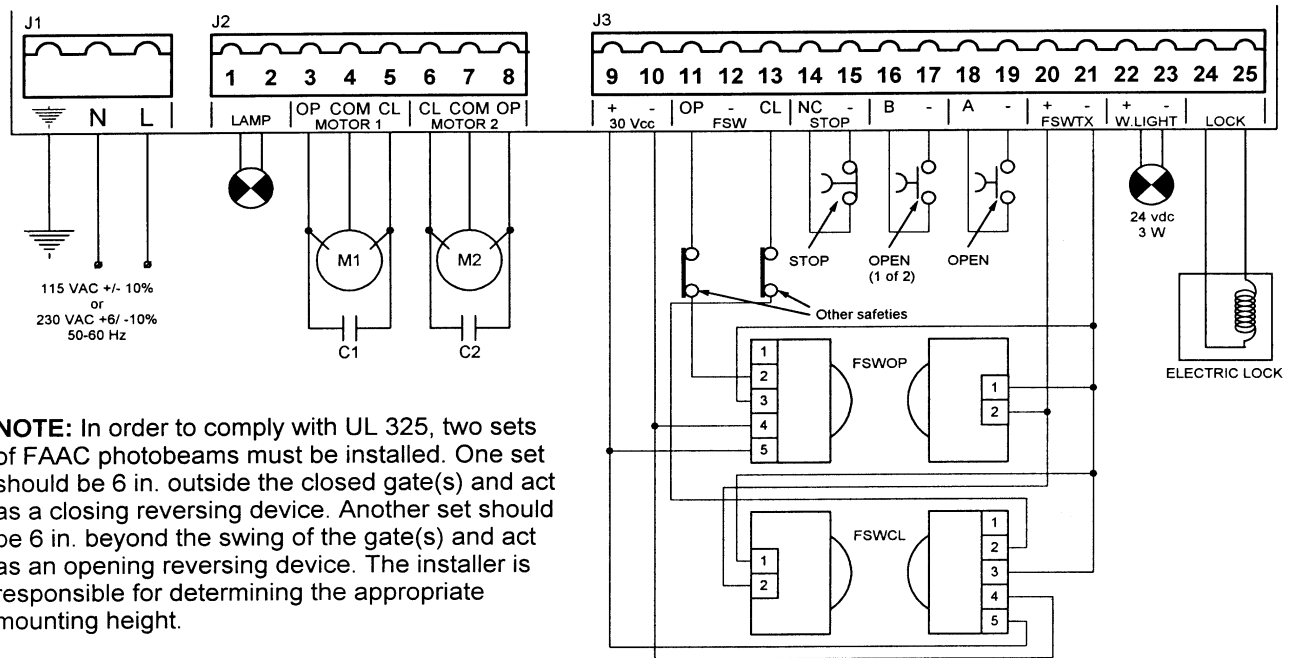

Figure 8. The 450 MPS control panel

		FUSES	220 VAC	115 VAC
1	J1 terminal block for main power supply			
2	J2 terminal block for connecting the operator(s)			
3	J3 terminal block for low-voltage accessories			
4	J4 quick connector port			
5	Pressure adjustment potentiometer	10	F1, Main power	5 A
6	Pause time potentiometer	11	F2, Accessories	800 mA
7	Potentiometer for adjusting open/close time	12	F3, Electric lock	1.6 A
8	Leaf delay potentiometer	13	F4, Microprocessor	250 mA
9	DIP switch assembly			



NOTE: In order to comply with UL 325, two sets of FAAC photobeams must be installed. One set should be 6 in. outside the closed gate(s) and act as a closing reversing device. Another set should be 6 in. beyond the swing of the gate(s) and act as an opening reversing device. The installer is responsible for determining the appropriate mounting height.

Figure 9. The terminal strip wiring of the 450 MPS with photobeams

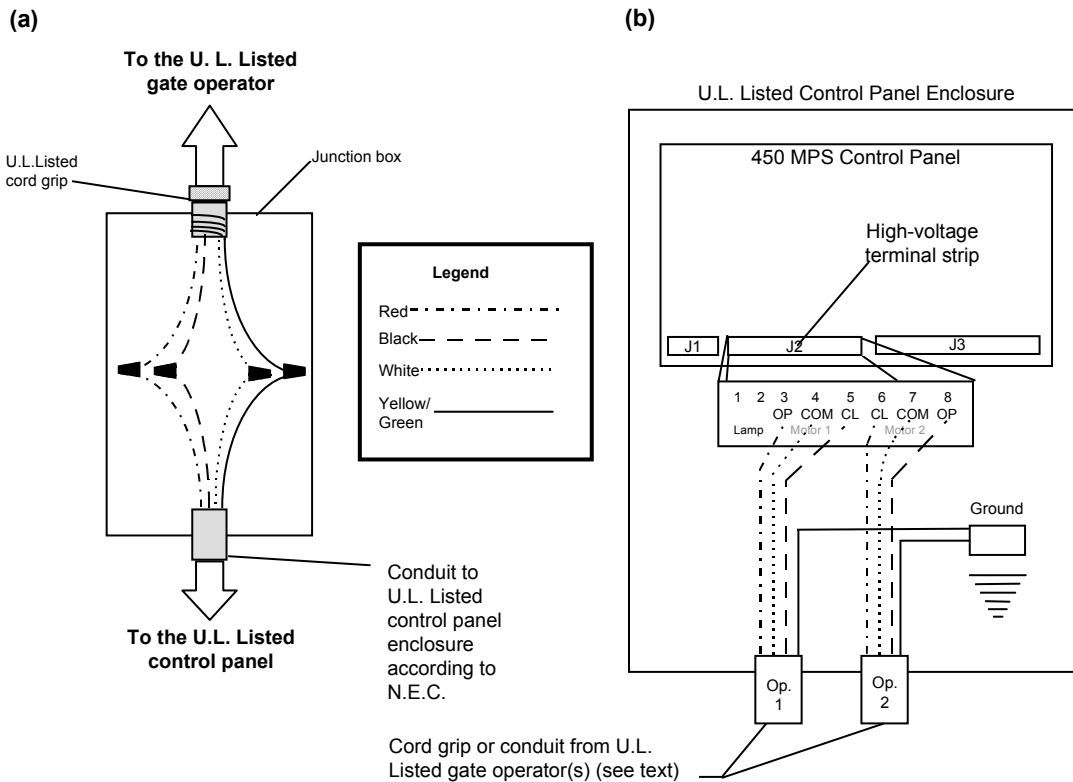

Figure 10. Wiring detail (a) inside the junction box and (b) from the junction box or operator to the high-voltage terminal strip on the 450 MPS control panel

CONNECT THE OPERATOR(S) TO THE CONTROL PANEL

WARNING! Turn the main power off before you make any electrical connections or set any switches inside the control panel box.

USING A JUNCTION BOX

Connecting your operator(s) to the control panel may require the use of one or more junction boxes. Whether you need 0, 1, or 2 U.L. Listed junction boxes depends on your gate design (refer to Figure 10).

If any operator is more than 2 ft away from the U.L. Listed control panel enclosure, the connection must be made inside a junction box. Use a U. L. Listed cord grip where the operator cord enters the junction box; use conduit between the junction box and the enclosure.

CAUTION: The control panel will **NOT** operate without an operator connected to terminals 3, 4, and 5.

If your gate system has one operator, connect the capacitor and the brown and black (or red and black) wires from your operator to the terminals 3 and 5 in block J2 for Motor 1. Connect the blue (or white) wire from the operator to terminal 4 for Motor 1.

Note: If you want to delay the closing of one gate leaf in a two-leaf gate design, be sure to connect its operator to Motor 1 (terminals 3, 4, and 5).

If your gate system has two operators, connect the second operator to terminals 6, 7, and 8 in block J2 for Motor 2. Connect the second capacitor and the brown and black (or red and black) wires to terminals 6 and 8, and connect the blue (or white) wire from the operator to terminal 7 for Motor 2.

CHECK THE MOTOR'S DIRECTION OF ROTATION

After you have connected the main power supply, one activating device, and the operator(s) to the control panel, you need to check the direction of rotation for each operator motor in your gate design.

To check a motor's direction of rotation, you must have three closed circuits on terminal block J3. Install one circuit between terminals 11 and 21, another circuit between 13 and 21, and another circuit (or stop device) between terminal 14 and 15.

You cannot check the motor's direction of rotation without these circuits (jumpers) or the accessories. When properly prepared for testing, the LEDs DL3, DL4, and DL5 should be illuminated.

WARNING! Running the operator—even for testing purposes—without a connected reversing device is potentially dangerous. Do not place yourself within the path of the moving gate during your test.

You also need to install a normally open activation device across terminals 18 and 19.

Disengage the operator(s) with the Manual Release key, and open the gate by hand about halfway.

Next, engage the operator(s) with the Manual Release key so that you can check the rotation of the motor(s).

Turn on the main power and send an activating signal to the operator(s). The gate leaf (or leaves) should open. If a gate leaf closes, then you need to turn off the main power and reverse the connection of the brown and black (or red and black) wires on terminal block J2 for the operator controlling that leaf. Then you need to recheck the rotation direction again.

If your gate system has two operators, be sure the motor of each rotates in the correct direction.

After having completed your test of the motor's direction of rotation, replace any test circuits you installed (between terminals 11 and 21, between 13 and 21, and between 14 and 15) with the proper reversing and stop devices. The instructions for installing such accessories follow.

CONNECT OTHER DEVICES

WARNING! Turn the main power off before you make any electrical connections or set any switches inside the control panel box.

Now you can connect additional reversing and activating devices to the control panel. Refer to Figure 11 for

the general control panel layout, and refer to Figure 9 for the layout of the terminal strip.

POWER SUPPLY FOR ACCESSORIES: You can access a 30 VDC output for supplying power to accessories that require DC voltage through terminals 9 and 10 (located above the label 30 Vcc) on terminal block J3. In most cases, this source can be used to power 24 VDC accessories.

NOTE: The 450 MPS control panel allows a maximum accessory load of 800 mA.

REVERSING DEVICES: Reversing devices include photobeams, inductive loops, and so forth. All of the reversing devices should have contacts of the normally closed (N.C.) type. Where you connect a device depends on whether you want the device to operate during opening or during closing.

Note: UL does not recognize the FAAC system with loop detectors or safety edges. FAAC photobeams must be used to comply with UL 325.

Caution: Failure of a reversing device that operates during opening causes a gate to lock in the closed position and requires the use of the Manual Release.

To wire photobeams, refer to Figure 9 (see FSWOP for opening photobeams, and FSWCL for closing photobeams— wire the photobeams exactly as shown). See Figure 11 for the wiring of a variety of common accessories. In either case, if you have multiple devices, wire them in series.

ACTIVATING DEVICE: The activating device for your gate must have normally open (N.O.) contacts. If you have a dual gate, connect devices to terminals 18 and 19. If you have a dual gate and want a particular device to open only one leaf, connect it to terminals 16 and 17.

DECODER CARD: If you are installing a FAAC radio receiver, a Digicard magnetic card reader, or a Digikey keypad, use the quick-fit connector J4 for the radio receiver or the DS (formerly the MD01) decoder card (see Figure 8).

NOTE: If you are using both a receiver and a decoder, hard wire the decoder and plug the receiver in.

OPEN/HOLD OPEN DEVICE: To open hold the gate open, you must use a latching switch wired to terminals 18 and 19.

STOP BUTTON: The stop button you install must have normally closed (N.C.) contacts. Multiple stop buttons must be wired in series. Connect your stop device between terminals 14 and 15.

THE LED INDICATORS: The five light-emitting diodes (LEDs) on the control panel can be used to check for the proper functioning of the devices you attach to the control panel. The LED lights are on whenever the contacts are closed across each of the respective terminals.

DL1 and DL2 should illuminate only when an activating signal is sent for 2 and 1 gate leaves, respectively. DL3 should be illuminated except when the stop button is pressed. DL4 and DL5 should be illuminated except when the reversing devices, for opening and closing, respectively, are triggered. Use the LEDs and the next table to determine if the accessory devices you have installed are operating properly.

LED	On	Off
DL1, A	Command active	Command inactive
DL2, B	Command active	Command inactive
DL3, Stop	Command not active	Command active
DL4, FTSW Open	Opening reversing devices not triggered	Reversing device triggered
DL5, FTSW Close	Closing reversing devices not triggered	Reversing device triggered

ELECTRIC LOCK: Connect your lock to the terminals 24 and 25. The terminals provide 12 VAC that pulses for 4 seconds whenever the gate starts to open. An electric lock can make use of the reversing stroke function controlled by DIP switch 5. A reversing stroke is a short closing phase that allows the electric lock time to disengage itself before the operator starts its opening. Turn DIP switch 5 on only if necessary for your lock to function correctly.

See Figure 11 for the wiring of a magnetic locking device.

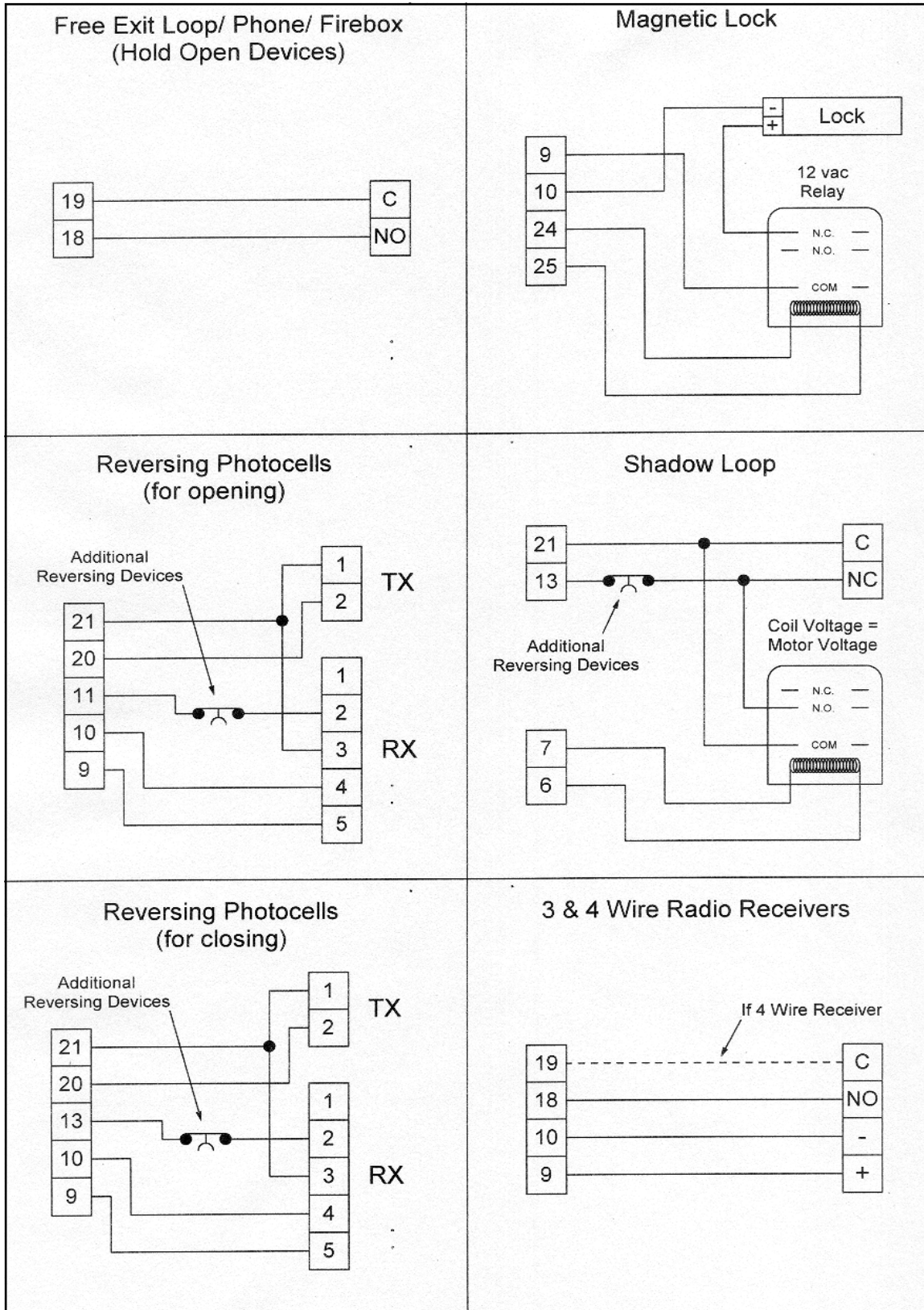

NO = Normally Open, NC = Normally Closed, C = Common, TX = Transmitter, RX = Receiver

Figure 11. Common Accessories wired to 450 MPS

WARNING LIGHT: Connect a warning light to terminals 22 and 23 in the group labeled *W.LIGHT* in terminal block J3. The terminals provide an output voltage of 30 VDC, maximum power 3 Watts. This output voltage will power most 24 VDC warning lights.

Note: The behavior of the warning light varies according to the logic you have set:

Logics A, S, E, EP, and B: The warning light is on steadily during opening and the pause phase. During closing, the light flashes.

Logic C: The warning light is on steadily during opening and flashes during closing.

SET OTHER OPERATING CONTROLS

WARNING! Turn off the main power before you make any electrical connections or set any switches inside the control panel box.

You need to set DIP switches and adjust the potentiometers on the control panel for your gate's operation. The 450 MPS Control Panel has 5 DIP switches and 4 potentiometers that control a wide range of functions.

SET DIP SWITCHES

Switches 1, 2, and 3 (Operating Logic): The 450 MPS Control Panel offers six operating modes: A, S, E, EP, B, and C. For more details about the logical modes, refer to the operating modes previously listed in this manual.

Switches 1, 2, and 3 control the operating logic according to the following scheme:

Logic	DIP Switch		
	1	2	3
A	on	off	on
S	on	off	off
E	off	on	off
EP	on	on	off
B	on	on	on
C	off	off	on

Switch 4 (Reversing Device Behavior on Closing): Refer to the operating logic tables earlier in these instructions and to the following table for how to set DIP switch 4.

Gate Behavior During Closing	DIP Switch 4
Gate immediately reverses its direction	off
Gate stops and reverse its direction when reversing device is no longer triggered	on

SWITCH 5 (REVERSING STROKE): Sometimes electric locks require a reversing stroke to disengage the lock. If your gate does not always open because your lock is hanging up, you may want to activate the Reversing Stroke.

Reversing Stroke	DIP Switch 5
Not activated	off
Activated	on

Adjust the Potentiometers

The four potentiometers control the torque, the pause time, the opening/closing time of operation, and the leaf delay on closing.

TORQUE: The torque potentiometer on the 450 MPS **must** be turned all the way clockwise for the 422 Operator. The potentiometer is for the FAAC Model 412, a screwdrive operator. The torque potentiometer cannot be used to adjust the operator's hydraulic operating pressures.

CAUTION: Failure to turn the torque potentiometer to maximum in the clockwise direction jeopardizes the life of the motor of your operator.

WARNING! Adjust the operating pressure on the 400 Operator only by means of the hydraulic bypass valve screws. See pages 11 and 19.

PAUSE TIME: The pause time between opening and closing can be adjusted from 0 to 240 seconds. Turn the potentiometer clockwise to increase the pause time and counterclockwise to decrease the pause time.

OPENING/CLOSING TIME: The opening/closing time is adjustable from 10 to 62 seconds. The approximate opening/closing time for a 90-degree opening is about 12 seconds. Turn the potentiometer clockwise to increase the time and counterclockwise to decrease the time.

For optimal operation, set the time so that the motor remains active for a couple of seconds after the leaf has reached its limit stop for opening and for closing.

LEAF DELAY: You may choose to delay one leaf on closing for overlapping gate leaves. Be sure the operator on the leaf for delayed closing is connected to Motor 1. On opening, the leaf connected to Motor 2 is delayed 2.5 sec.

Note: You cannot *adjust* this opening delay of the operator connected to Motor 2. However, you can turn off the delay by closing the jumper labeled "Leaf Delay Disable".

The closing leaf-delay time is adjustable from 0 to 28 seconds. Turn the potentiometer clockwise to increase the time and counterclockwise to decrease the time.

Note: If one-leaf gate designs, be sure to set the potentiometer for leaf delay to its minimum (0 seconds).

Note: If the opening/closing time is set at less than the leaf delay time, the delayed leaf closes at the end of the closing time.

LIMITED WARRANTY

To the original purchaser only: FAAC International, Inc., warrants, for twenty-four (24) months from the date of invoice, the gate operator systems and other related systems and equipment manufactured by FAAC S.p.A. and distributed by FAAC International, Inc., to be free from defects in material and workmanship under normal use and service for which it was intended *provided* it has been properly installed and operated. FAAC International, Inc.'s obligations under this warranty shall be limited to the repair or exchange of any part of parts manufactured by FAAC S.p.A. and distributed by FAAC International, Inc. Defective products must be returned to FAAC International, Inc., freight prepaid by purchaser, within the warranty period. Items returned will be repaired or replaced, at FAAC International, Inc.'s option, upon an examination of the product by FAAC International, Inc., which discloses, to the satisfaction of FAAC International, Inc., that the item is defective. FAAC International, Inc. will return the warranted item freight prepaid. The products manufactured by FAAC S.p.A. and distributed by FAAC International, Inc., are not warranted to meet the specific requirements, if any, of safety codes of any particular state, municipality, or other jurisdiction, and neither FAAC S.p.A. or FAAC International, Inc., assume any risk or liability whatsoever resulting from the use thereof, whether used singly or in combination with other machines or apparatus.

Any products and parts not manufactured by FAAC S.p.A. and distributed by FAAC International, Inc., will carry only the warranty, if any, of the manufacturer. This warranty shall not apply to any products or parts thereof which have been repaired or altered, without FAAC International, Inc.'s written consent, outside of FAAC International, Inc.'s workshop, or altered in any way so as, in the judgment of FAAC International, Inc., to affect adversely the stability or reliability of the product(s) or has been subject to misuse, negligence, or accident, or has not been operated in accordance with FAAC International, Inc.'s or FAAC S.p.A.'s instructions or has

been operated under conditions more severe than, or otherwise exceeding, those set forth in the specifications for such product(s). Neither FAAC S.p.A. or FAAC International, Inc., shall be liable for any loss or damage whatsoever resulting, directly or indirectly, from the use or loss of use of the product(s). Without limiting the foregoing, this exclusion from liability embraces a purchaser's expenses for downtime or for making up downtime, damages for which the purchaser may be liable to other persons, damages to property, and injury to or death of any persons. Neither FAAC S.p.A. or FAAC International, Inc., assumes nor authorizes any person to assume for them any other liability in connection with the sale or use of the products of FAAC S.p.A. or FAAC International, Inc. The warranty hereinabove set forth shall not be deemed to cover maintenance parts, including, but not limited to, hydraulic oil, filters, or the like. No agreement to replace or repair shall constitute an admission by FAAC S.p.A. or FAAC International, Inc., of any legal responsibility to effect such replacement, to make such repair, or otherwise. This limited warranty extends only to wholesale customers who buy directly through FAAC International, Inc.'s normal distribution channels. FAAC International, Inc., does not warrant its products to end consumers. Consumers must inquire from their selling dealer as to the nature and extent of that dealer's warranty, if any.

This warranty is expressly in lieu of all other warranties expressed or implied including the warranties of merchantability and fitness for use. This warranty shall not apply to products or any part thereof which have been subject to accident, negligence, alteration, abuse, or misuse or if damage was due to improper installation or use of improper power source, or if damage was caused by fire, flood, lightning, electrical power surge, explosion, wind storm, hail, aircraft or vehicles, vandalism, riot or civil commotion, or acts of God.

FAAC International, Inc.
303 Lexington Avenue
Cheyenne, WY 82007
www.faacusa.com