

THE 400 OPERATOR AND 450 MPS CONTROL PANEL: INSTALLATION MANUAL

CONTENTS

Important Safety Information	2
Technical Data	4
Unpacking the Operator	5
The 400 Compact Operator	6
General Characteristics	6
450 MPS Logic Modes	6
Installation Instructions	9
Prepare the Gate	9
Manual Release Mechanism	9
Install the Operator	9
Install the 450 MPS Control Panel	12
Connect the Main Power Supply	13
Connect the Operator(s) to the Control	15
Check the Motor's Direction of Rotation	15
Connect Other Devices	15
Set Other Operating Controls	18
Maintenance	20
The 400 Operator	20
The Control Panel	20
Troubleshooting	21
Exploded View, 400 CBC	22
400 Parts List	23
Limited Warranty	24

FAAC International, Inc.
303 Lexington Avenue
Cheyenne, WY 82007
www.faacusa.com

FAAC[®]

INTERNATIONAL, INC.

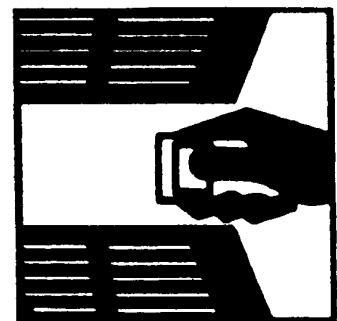

FAAC is an ISO 9001 Certified Company

IMPORTANT SAFETY INFORMATION

Both the installer and the owner and/or operator of this system need to read and understand this installation manual and the safety instructions supplied with other components of the gate system. This information should be retained by the owner and/or operator of the gate.

WARNING! To reduce the risk of injury or death

1. **READ AND FOLLOW ALL INSTRUCTIONS.**
2. Never let children operate or play with gate controls. Keep the remote control away from children.
3. Always keep people and objects away from the gate. **NO ONE SHOULD CROSS THE PATH OF THE MOVING GATE.**
4. Test the gate operator monthly. The gate **MUST** reverse on contact with a rigid object or stop when an object activates the non-contact sensors. After adjusting the force or the limit of travel, retest the gate operator. Failure to adjust and retest the gate operator properly can increase the risk of injury or death.
5. Use the emergency release only when the gate is not moving.
6. **KEEP GATES PROPERLY MAINTAINED.** Read the owner's manual. Have a qualified service person make repairs to gate hardware.
7. The entrance is for vehicles only. Pedestrians must use separate entrance.
8. **SAVE THESE INSTRUCTIONS.**

When installing the photo-beams supplied with this unit two things need to be considered.

1. Care should be exercised to reduce the risk of nuisance tripping, such as when a vehicle, trips the sensor while the gate is in motion.
2. One or more photobeams shall be located where the risk of entrapment exists, such as the perimeter reachable by the moving gate leaf.

GATE DESIGN

1. A gate is a potential traffic hazard, so it is important that you locate the gate far enough away from the road to eliminate the potential of traffic getting backed up. This distance is affected by the

size of the gate, how often it is used, and how fast the gate operates.

2. The operator you choose to install on your gate must be designed for the type and size of your gate and for the frequency with which you use the operator.
3. Your gate must be properly installed and must work freely in both directions before the automatic operator is installed.
4. An automatic operator should be installed on the inside of the property/fence line. Do not install the operator on the public side of the property/fence line.
5. Pedestrians should not use a vehicular gate system. Prevent such inappropriate use by installing separate gates for pedestrians.
6. Exposed, reachable pinch points on a gate are potentially hazardous and must be eliminated or guarded.
7. Outward swinging gates with automatic operators should not open into a public area.
8. The operating controls for an automatic gate must be secured to prevent the unauthorized use of those controls.
9. The controls for an automatic gate should be located far enough from the gate so that a user cannot accidentally touch the gate when operating the controls.
10. An automatic gate operator should not be installed on a gate if people can reach or extend their arms or legs through the gate. Such gates should be guarded or screened to prevent such access.

INSTALLATION

1. If you have any question about the safety of the gate operating system, do not install this operator. Consult the operator manufacturer.
2. The condition of the gate structure itself directly affects the reliability and safety of the gate operator.
3. Only qualified personnel should install this equipment. Failure to meet this requirement could cause severe injury and/or death, for which the manufacturer cannot be held responsible.
4. The installer must provide a main power switch that meets all applicable safety regulations.
5. Clearly indicate on the gate with the 2 warning signs that are included (visible from either side of the gate).

6. It is extremely unsafe to compensate for a damaged gate by increasing hydraulic pressure.
7. Devices such as reversing edges and photobeams must be installed to provide better protection for personal property and pedestrians. Install reversing devices that are appropriate to the gate design and gate application.
8. Before applying electrical power, be sure that the voltage requirements of the equipment correspond to your supply voltage. Refer to the label on your operator system.

USE

1. Use this equipment only in the capacity for which it was designed. Any use other than that stated should be considered improper and therefore dangerous.
2. When using any electrical equipment, observe some fundamental rules:
 - Do not touch the equipment with damp or humid hands or feet.

- Do not install or operate the equipment with bare feet.
 - Do not allow small children or incapable persons to use the equipment.
3. If a gate system component malfunctions, turn off the main power before making any attempt to repair it.
 4. Do not attempt to impede the movement of the gate. You may injure yourself as a result.
 5. This equipment may reach high temperatures during operation; therefore, use caution when touching the external housing of the operator.
 6. Learn to use the manual release mechanism according to the procedures found in this installation manual.
 7. Before carrying out any cleaning or maintenance operations, disconnect the equipment from the electrical supply.
 8. To guarantee the efficiency of this equipment, the manufacturer recommends that qualified personnel periodically check and maintain the equipment.

U.L. CLASS AND FAAC OPERATOR

Model	Duty Cycle	Typical Use
Class I: Residential Vehicular Gate Operator		
402	750	<ul style="list-style-type: none"> • Home use • Small apartment building, for example, up to 4 units in a building, with limited public access
422	760	
412	400	
620	640	
885		
	Limited duty	
Class II: Commercial/General Access Vehicular Gate Operator		
400	640	<ul style="list-style-type: none"> • Apartment buildings • Very public access
620	885	
	Continuous duty	
Class III: Industrial/Limited Access Vehicular Gate Operator		
400	640	<ul style="list-style-type: none"> • No public access
620	885	
	Continuous duty	
Class IV: Restricted Access Vehicular Gate Operator		
620	640	<ul style="list-style-type: none"> • Prison rated security
885		
	Continuous duty	

TECHNICAL DATA

THE 400 OPERATOR

Parameter	400 Model			
	Standard	High Speed	Slow Speed	Long
Model	CBC ² CBA ³ CBAC ⁴ SB ¹	CBCR ² CBAR ³ CBACR ⁴	SBS ¹	CBC ² CBAC ⁴
Duty type	Apartment, subdivision, industrial, and commercial applications			
Duty cycle	80 Cycles/ Hour			
Maximum leaf length ⁵ , ft (m)	18 (5.4)	12 (3.6)	20 (6)	18 (5.4)
Maximum leaf weight, lb (kg)	1300 (600)	900 (400)	2000 (900)	1300 (600)
Maximum leaf swing, deg	115			125
Thrust and traction, lb (kg)	0-1760 (0-800)			
90 deg opening time, sec ⁶	17	12	23	18
Operating temperature range, deg F (deg C)	-33 to 165 (-36 to 75)			
Thermal cut out, deg F (deg C)	212 (100)			
Hydraulic locking	Opened and/or closed	None	Opened and/or closed	
Operator dimensions, l ´ w ´ h, in. (cm)	40 X 3 ^{5/16} X 3 ^{5/16}			47 ^{1/2} X 3 ^{5/16} X 3 ^{5/16} (121 X 3 X 8.5)
Operator weight, lb (kg)	19 (8.6)			
Power voltage required, VAC ⁷	115 VAC ±10%, 60 Hz, or 230 VAC +6 or -10%, 60 Hz			
Amp Draw	115V = 1.5 Amps; 230V = 1 Amp			
Type of oil	Lubrication Engineers - MONOLEC 6105			
Oil quantity, qt (l)	2 ^{1/3} (2.2)			2 ^{7/8} (2.7)

1 The operator requires external locks.

2 Locks in the extended position. The hydraulic lock is a service device, not a security device.

3 Locks in the retracted position. The hydraulic lock is a service device, not a security device.

4 Locks in both the extended and retracted positions. The hydraulic lock is a service device, not a security device.

5 External locks are recommended if the gate leaves are 12 ft (3.6 m) or longer.

6 The time may vary ±10%.

7 Your standard 220 VAC power source meets the specification for 230 VAC, +6 or -10%.

THE CONTROL PANEL

The 400 Operator must be installed with a 450 MPS control panel to be a U.L. recognized installation. The 450 MPS can be used to control a single 400 operator or a dual (bi-parting) system. Both the control panel and the operator must use the same power supply voltage.

THE 450 MPS

To determine the voltage requirement of your 450 MPS control panel, refer to the label on the transformer of the control panel:

Label reads: 1450MPSUS = 220 VAC

1450MPSUS115 = 115 VAC

Operating logics available: E, EP, A, S, B, and C

UNPACKING THE OPERATOR

When you receive your 400 Operator, complete the following steps.

Inspect the shipping box for physical damage such as leaking oil or a torn carton. Then inspect the operator after you remove it from the box. Notify the carrier immediately if you note any damage. The carrier must witness the damage before you can file a claim.

As you unpack the box, insure that all the following parts included (see Figure 1). If you have ordered a kit (a pair of operators), you will have twice the quantity of parts listed below (except where noted), and you will also have a radio receiver and two transmitters.

- 1 400 Operator - 1 each
- 2 Protective Cover - 1 each
- 3 Protective Cover Tie-Rods - 2 each
- 4 Protective Cover End Cap - 1 each
- 5 Rear Mounting Bracket - 1 each
- 6 Rear Mounting Plate (optional) - 1 each
- 7 Short Brass Pin with 8mm nut and washer - 1 each
- 8 Rear Fork - 1 each
- 9 Long Brass Pin with 8mm self-locking nut - 1 each
- 10 Swivel joint with jam nut and washer - 1 each
- 11 Front mounting bracket with nut and bolt
- 12 Locking cap cover and key for Manual Release - 1 each

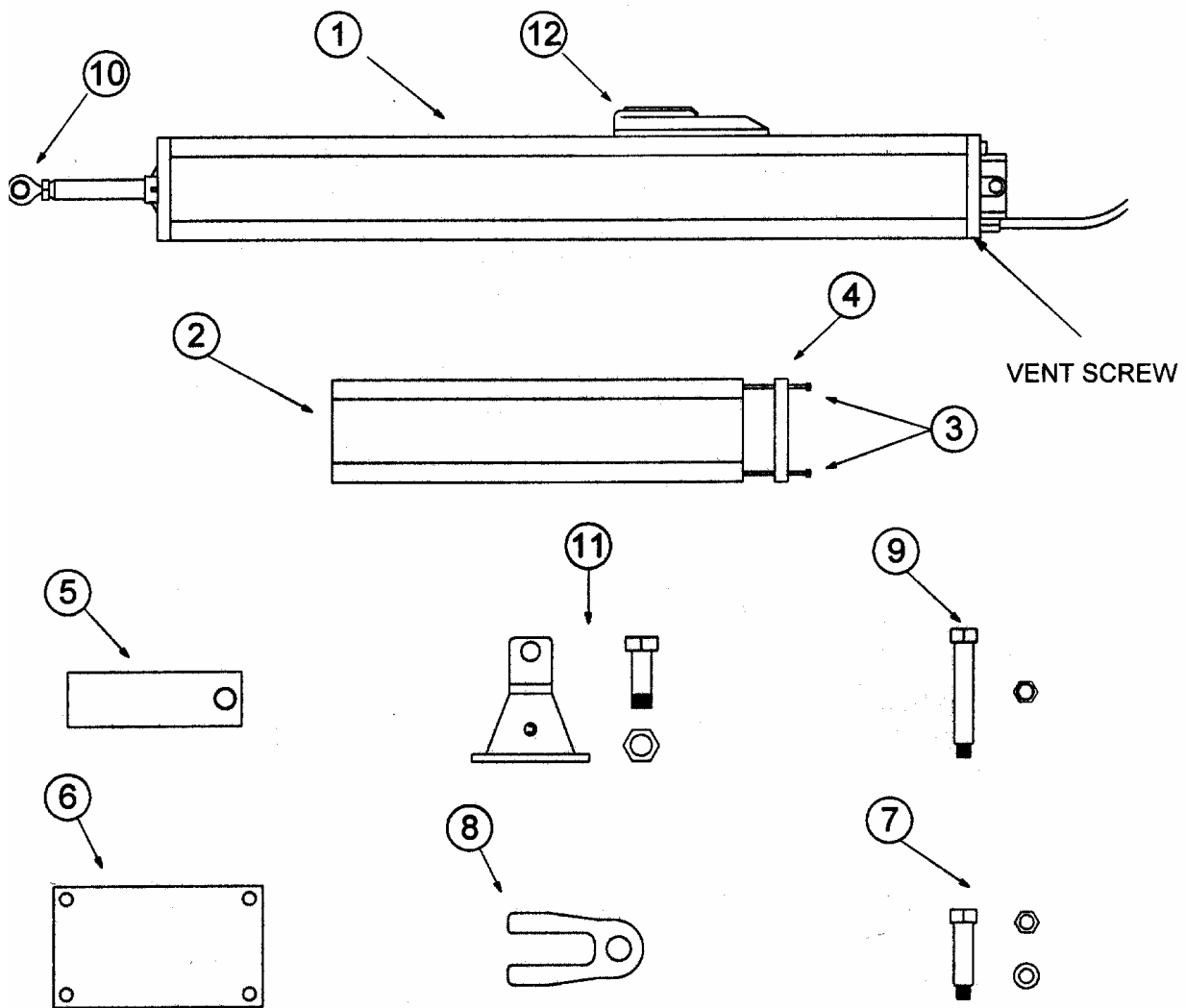

Figure 1. Parts of the 400 Operator

THE 400 OPERATOR

GENERAL CHARACTERISTICS

The FAAC 400 Operator is an automatic gate operator for a swinging gate leaf. It can accommodate a gate leaf of up to 2000 lb (900 kg) and up to 20 ft (6 m) in length.

The self-contained 400 Operator is an electro-hydraulic unit consisting of an electric motor, a pump, a valve assembly, and a hydraulic cylinder, all housed in an anodized aluminum oil reservoir.

The 400 Operator can be used to swing the gate leaf inward or outward. Most versions provide hydraulic locking in at least one position, either opened or closed, depending on how it was ordered.

The hydraulic lock is a service device rather than a security device. Additional, external locks are recommended under the following conditions:

- You are installing the Model 400 SB
- The length of the gate leaf is 12 ft or more
- The installation requires tight security
- The site is subject to vandalism
- The site is subject to strong or very gusty wind
- You are installing a solid face gate

For gates with two leaves, two operators are installed, one on each leaf, and both are wired to one control panel. In such two-operator gate installations, one leaf can be programmed to open/ close slightly later than the other leaf to accommodate overlapping gate designs.

For its protection, the single-phase, bidirectional motor shuts off automatically if its operating temperature reaches 212 deg F (100 deg C). Also for the protection and proper operation of the 400 Operator, each gate leaf on which it is installed must have a fixed positive stop in both the opened and closed positions.

The 400 Operator also includes a key-operated Manual Release mechanism and two bypass valves that pre-cisely control the force applied to the gate leaf through the 400 Operator.

The Manual Release mechanism is a key-operated device that disengages (or engages) the hydraulic system of the 400 Operator. When the hydraulic system is disengaged, you can open and close the gate leaf by

hand. Such manual operation of the gate is necessary during installation and useful during power failures. The two bypass valves are located beneath the locking cap. You need to adjust the bypass valves to meet the safety standards of FAAC International, Inc. The standards state that the gate leaf should stop if it encounters a force of more than 33 lb (15 kg).

Additional reversing devices (such as inductive loops and photocells) should be installed to provide more complete protection for people and property.

The electronic control panel is a microprocessor-based controller that accepts a wide range of product accessories and reversing devices, thus allowing for flexible gate system design.

450 MPS LOGIC MODES

Note: The 450 provides inputs for opening reversing devices and closing reversing devices. FAAC strongly recommends the use of reversing devices, such as photocells or other non-contact sensors.

- **A (automatic):** The gate opens on command and automatically closes after a pause phase. A second command while opening is ignored; a second command during the pause phase interrupts the pause time; a second command during closing reopens the gate. A maintained open command will hold the gate open.
- **S (security):** The security mode is like A logic except that a second command during opening immediately closes the gate. A maintained open command will not hold the gate open.
- **E (semi-automatic):** This mode requires a command to open and a command to close. A second command during opening stops the gate. A second command during closing reopens the gate.
- **EP (semi-automatic, step by step):** This mode requires a command to open and a command to close. A second command during opening or closing causes the gate to stop. A third command then reverses the previous motion of the gate.
- **B (manned, pulsed):** This mode is designed for guard station use and requires a three-button switch (pulsed) to open, close, and stop the gate.
- **C (manned and constant):** This mode requires constant pressure switches. One to open and one to close. No pressure on a switch stops the gate.

A (Automatic) Logic (450 MPS)

Gate Status	Open A	Open B	Stop	Opening Reversing Device(s)	Closing Reversing Device(s)	Warning Light
Closed	Opens both leaves and closes them after pause time	Opens single leaf connected to Motor 1 and closes it after pause time	No effect	No effect	No effect	Off
Opening	No effect	No effect	Stops	Stops; gate closes when reversing device no longer triggered	No effect	On
Opened	Interrupts the pause time	Interrupts the pause time	Stops	No effect	Gate remains open until reversing devices no longer triggered	On
Closing	Opens both leaves	Opens leaf	Stops	No effect	Depends on DIP switch 4	Flashes
Stopped	Closes the leaves	Closes the leaf	No effect (opening is inhibited)	No effect	No effect (opening is inhibited)	On

S (Security) Logic (450 MPS)

Gate Status	Open A	Open B	Stop	Opening Reversing Device(s)	Closing Reversing Device(s)	Warning Light
Closed	Opens both leaves and closes them after pause time	Opens single leaf connected to Motor 1 and closes it after pause time	No effect	No effect	No effect	Off
Opening	Closes both leaves	Closes leaf	Stops	Stops; gate closes when reversing device no longer triggered	No effect	On
Opened	Closes both leaves	Closes leaf	Stops	No effect	Gate remains open until reversing devices no longer triggered	On
Closing	Opens both leaves	Opens leaf	Stops	No effect	Depends on DIP switch 4	Flashes
Stopped	Closes the leaves	Closes the leaf	No effect (opening is inhibited)	No effect	No effect (opening is inhibited)	On

B (Manned, Pulsed) Logic (450 MPS)

Gate Status	Open A	Open B	Stop	Opening Reversing Device(s)	Closing Reversing Device(s)	Warning Light
Closed	Opens 1 or both leaves	No effect	No effect	No effect	No effect	Off
Opening	No effect	No effect	Stops	No effect	Stops	On
Opened	No effect	Closes 1 or both leaves	No effect	No effect	No effect	On
Closing	No effect	No effect	Stops	Stops	No effect	Flashes
Stopped	Opens 1 or both leaves	Closes 1 or both leaves	No effect	No effect	No effect	On

E (Semi-automatic) Logic (450 MPS)

Gate Status	Open A	Open B	Stop	Opening Reversing Device(s)	Closing Reversing Device(s)	Warning Light
Closed	Opens both leaves	Opens single leaf connected to Motor 1	No effect	No effect	No effect	Off
Opening	Stops	Stops	Stops	Stops; gate closes when reversing device no longer triggered	No effect	On
Opened	Closes both leaves	Closes leaf	Stops	No effect	No effect (opening is inhibited)	On
Closing	Closes both leaves	Closes leaf	Stops	No effect (opening is inhibited)	Depends on DIP switch 4	Flashes
Stopped	Closes the leaves	Closes the leaf	No effect (opening is inhibited)	No effect	No effect (opening is inhibited)	On

EP (Semi-automatic, Step by Step) Logic (450 MPS)

Gate Status	Open A	Open B	Stop	Opening Reversing Device(s)	Closing Reversing Device(s)	Warning Light
Closed	Opens both leaves	Opens single leaf connected to Motor 1	No effect (opening is inhibited)	No effect (opening is inhibited)	No effect (opening is inhibited)	Off
Opening	Stops	Stops	Stops	Stops; gate closes when reversing device no longer triggered	No effect	On
Opened	Closes both leaves	Closes leaf	Stops	No effect	No effect (opening is inhibited)	On
Closing	Stops	Stops	Stops	No effect (opening is inhibited)	Depends on DIP switch 4	Flashes
Stopped	Gate leaves reverse direction	Gate leaf reverses direction	No effect (opening is inhibited)	No effect (opening is inhibited)	No effect (opening is inhibited)	On

C (Manned and Constant) Logic (450MPS)

Gate Status	Open A	Open B	Stop	Opening Reversing Device(s)	Closing Reversing Devices(s)	Warning Light
Closed	Opens 1 or both leaves	No effect	No effect	No effect	No effect	Off
Opening	No effect	No effect	Stops	No effect	Stops	On
Opened	No effect	Closes 1 or both leaves	No effect	No effect	No effect	On
Closing	No effect	No effect	Stops	Stops	No effect	Flashes
Stopped	Opens 1 or both leaves	Closes 1 or both leaves	No effect	No effect	No effect	On

INSTALLATION INSTRUCTIONS

Installing the 400 Operator involves preparing the gate, installing the operator(s), installing the control panel, and fine-tuning the pressure adjustments on the operator(s).

Note: The following installation instructions assume you are fully capable of installing an operator. This manual does not instruct you in designing a gate, installing a gate, or basic electrical wiring. The installation tasks discussed in this manual are tasks particular to the 400 Operator.

PREPARING THE GATE

Before installing the 400 Operator, you need to prepare the gate itself for the operator. Be sure to do the following things:

1. Make sure that the gate is plumb.
2. Make sure that the gate moves smoothly on its hinges without excessive friction by swinging it open and closed by hand. Lubricate all the gates' moving parts.
3. Provide positive stops for the gate leaves in the fully open and fully closed positions (see Figure 2).

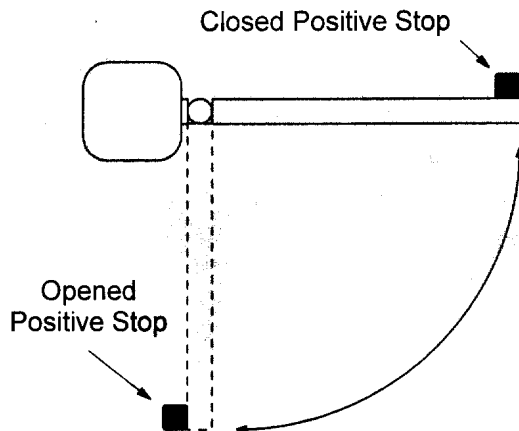

Figure 2. Positive Stops

MANUAL RELEASE MECHANISM

For installation of the locking cap cover see page 20. To access the keyhole, slide the key-hole cover in the direction of the arrow (see Figure 3). Insert the key and turn it counterclockwise one full turn to disengage the

operator's hydraulic system. You can now move the gate leaf slowly by hand to open or close the gate.

Operating the gate leaf by hand is necessary during installation and is useful during power failures.

You re-engage the hydraulic system by turning the key clockwise one full turn. Remove the key and slide the cover closed.

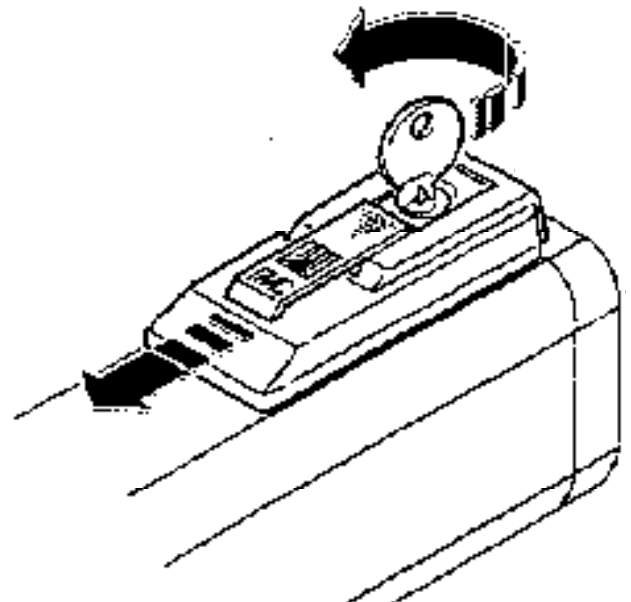

Figure 3. After sliding the cover open on the Model 400, insert and turn the key counterclockwise one full turn to release the hydraulic system

INSTALLING THE OPERATOR

Installing the 400 operator consists of the following steps:

1. Attach the rear mounting bracket
2. Attach the mounting hardware
3. Attach the front mounting bracket
4. Attach the operator to the gate
5. Adjust the operator pressure

ATTACH THE REAR MOUNTING BRACKET

Attach the rear mounting bracket according to the dimensions in Figure 4.

WARNING! You must achieve the A and B dimensions, as specified in Figure 4. Modification of the rear bracket may be necessary to achieve these dimensions (i.e., cutting or extending the bracket provided)

If you have a steel gate post, weld the rear bracket directly to it. If the gate post is made of any other material, attach the optional mounting plate, with lag bolts or anchors, and weld the bracket to it.

For an outward swing gate refer to Figure 5.

ATTACH THE MOUNTING HARDWARE

Insert the rear fork (hex cut up if you have a nylon rear fork) into the rear flange of the operator. Secure with long brass pin and self-locking nut.

Screw the jam nut onto the swivel joint. Slide the washer on next and screw the swivel joint halfway into the piston rod. Temporarily attach the front mounting bracket to the swivel joint with the nut and bolt provided.

ATTACH THE FRONT MOUNTING BRACKET TO THE OPERATOR

Release the operator as shown in Fig. 3. Put the operator into position and attach the rear fork to the rear mounting bracket using the short brass pin, washer, and nut.

For inward swing, pull the piston out completely and push back approximately 1/4" (6mm). For outward swing, push the piston in completely and pull back out approximately 1/4" (6mm).

Note: Be sure that the operator is level and that the gate is against the close positive stop.

Hold the front mounting bracket flush against the gate. Mark the location of the front mounting bracket. Remove the operator from the gate. Remove the front mounting bracket from the swivel joint.

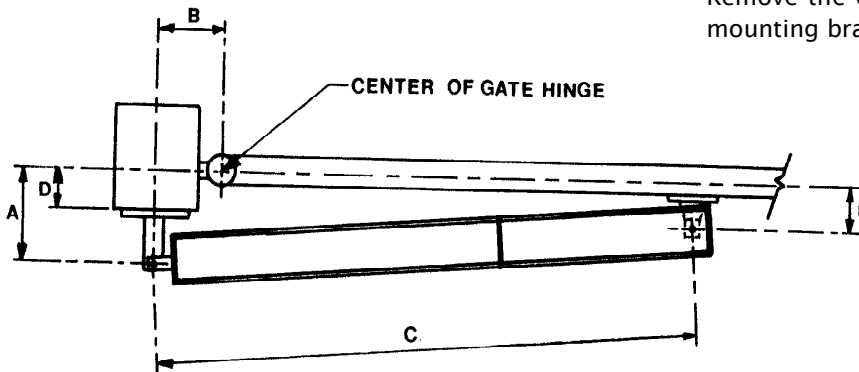

Figure 4. Important mounting dimensions for inward swing 400 operators, top view

	Desired Swing	Dimensions, in. (cm)	
		400 Standard High speed and Slow speed models	400 Long
A	90-deg swing 115-deg swing 125-deg swing	5 (13) 4 (10) N/A	7 7/8 (20)* or 11 1/2 (29)** 5 3/4 (14.6) 5 1/8 (13)
B	90-deg swing 115-deg swing 125-deg swing	5 (13) 4 3/4 (12) N/A	7 1/2 (19)* or 3 (7.5)** 7 (17.8) 6 5/8 (17)
C	All Swings	38 3/16 (97)	47 5/8 (121)
D	90-deg swing 115-deg swing 125-deg swing	Max 3 (8) Max 2 (5) N/A	Max 5.5 (14)* or 9.5 (24)** Max 3 1/2 (8.9) Max 2 3/4 (7)
E	All Swings	Must be less than A	

* For A, B, and D, if you choose one of these values with one asterisk, then you must choose the other values with one asterisk.

** For A, B, and D, if you choose one of these values with two asterisks, then you must choose the other values with two asterisks.

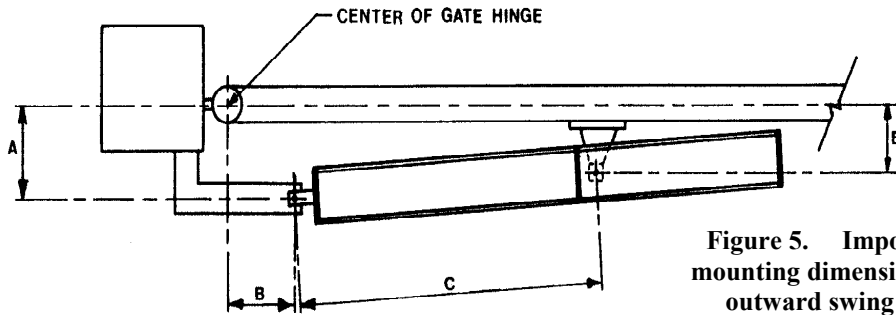

Figure 5. Important mounting dimensions for outward swing 400 operators, top view

Dimensions, In. (cm)	
	400 Standard, high speed, and slow speed models
A	5 (13)
B	5 (13)
C	27 ^{9/16} (70)
D	No Limit
E	Must be less than A

Note: Clamping the front mounting bracket at the marked location before checking the swing, as instructed below, will ensure proper location of the front mounting bracket.

Bolt or weld the front mounting bracket to the marked location on the gate.

WARNING! Do not weld the front mounting bracket with the operator attached. Doing so will seriously damage the operator.

ATTACH THE OPERATOR TO THE GATE

Re-attach the operator to the mounting brackets. Once the operator is mounted and level, remove the vent screw from the bottom of the rear flange. (See Figure 1) Use the 3mm hex key on the end of the screwdriver provided.

WARNING! Failure to remove the vent screw may result in erratic operation of the operator or blown seals.

Slowly move the gate open and close.

WARNING! The piston should not bottom out in either direction. Doing so will seriously damage the operator.

Be sure that the gate reaches the positive stop before the piston bottoms out. Adjust the swivel joint if necessary.

After checking the swing of the gate, secure all nuts and bolts, including the jam nut on the swivel joint.

Once the operator is secure, attach the protective cover to the front flange with the tie rods and end cap provided.

Note: Lubricating the threads of the protective cover tie rods can prevent them from freezing up and breaking if operator is ever removed for service.

Once the protective cover is installed, swing the gate to ensure that it does not contact the cover at any point of the swing.

Re-engage the operator by inserting the key in the locking cap (see Figure 3) and turning it clockwise until snug. Remove the key.

INSTALLING THE 450 MPS CONTROL PANEL

Locate the control panel in the most convenient position possible, considering the movement of the gate. Figure 7 shows a basic layout for a two-leaf gate with the 400 Operator.

Installing the control panel consists of the following general steps:

- Connecting the main power to the control panel
- Connecting the activating device
- Connecting the operator to the control panel
- Checking the direction of the motor's rotation
- Connecting other devices to the control panel
- Set operating modes

The installer is responsible for grounding the gate and operator systems, for providing the main power breaker switch, and for making sure that the entire gate system

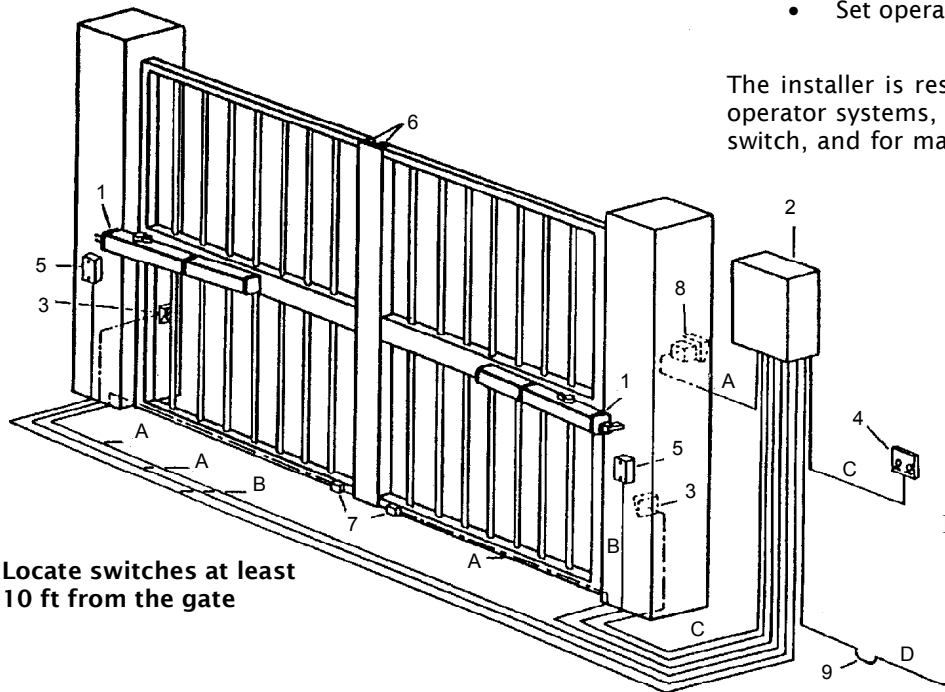

Figure 7. The layout of a sample gate system

- 1 Operator
- 2 Control Panel
- 3 Photocell
- 4 Switch
- 5 Junction box (see text)
- 6 Reversing edges
- 7 Gate stops
- 8 Switch
- 9 Wiring to main circuit breaker

Wire Gauges for Given Voltage

	220 VAC	115 VAC
A	2 × 18 AWG	A 2 × 18 AWG
B	4 × 14 AWG	B 4 × 14 AWG
C	5 × 18 AWG	C 5 × 18 AWG
D	4 × 14 AWG up to 414 ft	D 3 × 14 AWG up to 130 ft 3 × 10 AWG up to 340 ft

CONNECT THE MAIN POWER SUPPLY

WARNING! Turn the main power off before you make any electrical connections or set any switches inside the control panel box.

Connect the ground to the grounding terminal in block J1 and connect the power wires to the terminals labeled N (neutral) and L (line).

Wire the main power supply to control panel terminals in block J1 (see Figures 8 and 9). The installer is responsible for insuring that a separate, grounded circuit protected by a circuit breaker is between the control panel and the main power supply. All wiring should conform to applicable electrical codes, and all wiring and fittings should be weatherproof and/or suitable for burial.

CAUTION: The operators are grounded only by the grounded circuit the installer provides.

NOTE: For a 230V system, a neutral is not needed. Connect one 115V line to the L (Line) and a second 115V line to the N (Neutral).

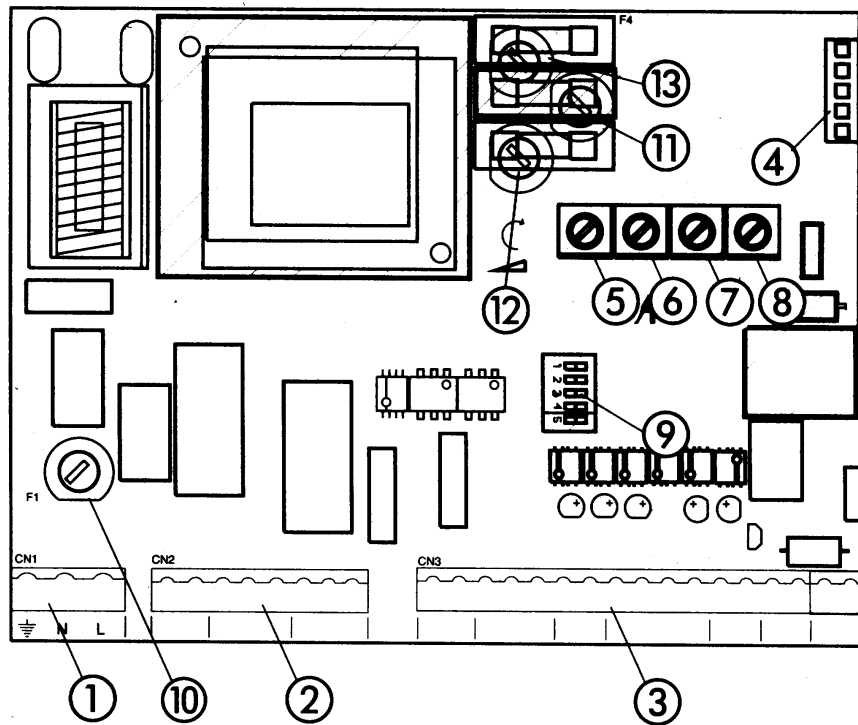
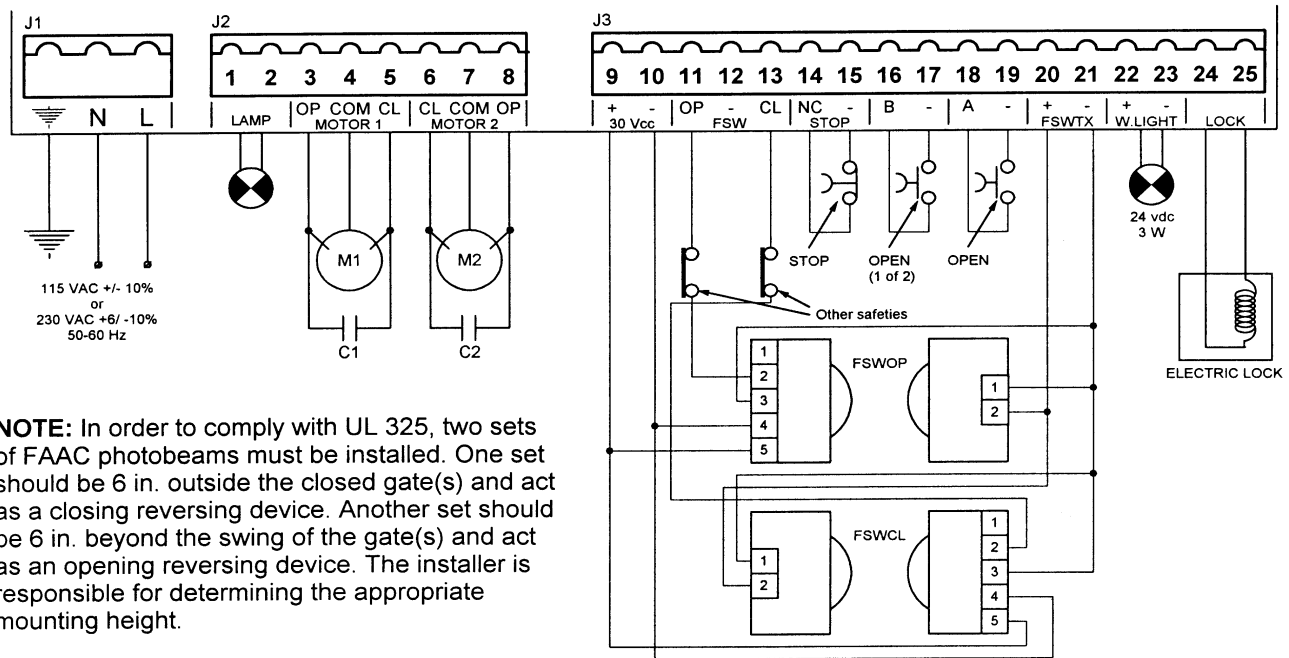

Figure 8. The 450 MPS control panel

		FUSES	220 VAC	115 VAC
1	J1 terminal block for main power supply			
2	J2 terminal block for connecting the operator(s)	10	F1, Main power	5 A 10 A
3	J3 terminal block for low-voltage accessories	11	F2, Accessories	800 mA 800 mA
4	J4 quick connector port	12	F3, Electric lock	1.6 A 1.6 A
5	Pressure adjustment potentiometer	13	F4, Microprocessor	250 mA 250 mA
6	Pause time potentiometer			
7	Potentiometer for adjusting open/close time			
8	Leaf delay potentiometer			
9	DIP switch assembly			



NOTE: In order to comply with UL 325, two sets of FAAC photobeams must be installed. One set should be 6 in. outside the closed gate(s) and act as a closing reversing device. Another set should be 6 in. beyond the swing of the gate(s) and act as an opening reversing device. The installer is responsible for determining the appropriate mounting height.

Figure 9. The terminal strip wiring of the 450 MPS with photobeams

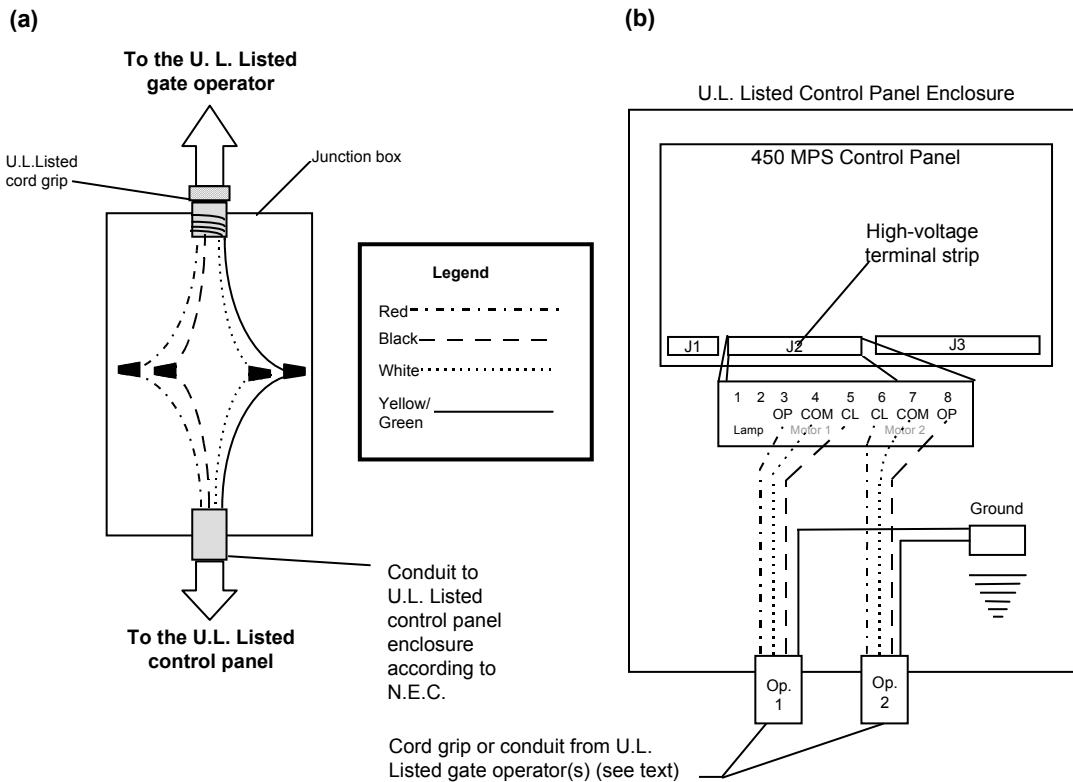

Figure 10. Wiring detail (a) inside the junction box and (b) from the junction box or operator to the high-voltage terminal strip on the 450 MPS control panel

CONNECT THE OPERATOR(S) TO THE CONTROL PANEL

WARNING! Turn the main power off before you make any electrical connections or set any switches inside the control panel box.

USING A JUNCTION BOX

Connecting your operator(s) to the control panel may require the use of one or more junction boxes. Whether you need 0, 1, or 2 U.L. Listed junction boxes depends on your gate design (refer to Figure 10).

If any operator is more than 2 ft away from the U.L. Listed control panel enclosure, the connection must be made inside a junction box. Use a U. L. Listed cord grip where the operator cord enters the junction box; use conduit between the junction box and the enclosure.

CAUTION: The control panel will **NOT** operate without an operator connected to terminals 3, 4, and 5.

If your gate system has one operator, connect the capacitor and the brown and black (or red and black) wires from your operator to the terminals 3 and 5 in block J2 for Motor 1. Connect the blue (or white) wire from the operator to terminal 4 for Motor 1.

Note: If you want to delay the closing of one gate leaf in a two-leaf gate design, be sure to connect its operator to Motor 1 (terminals 3, 4, and 5).

If your gate system has two operators, connect the second operator to terminals 6, 7, and 8 in block J2 for Motor 2. Connect the second capacitor and the brown and black (or red and black) wires to terminals 6 and 8, and connect the blue (or white) wire from the operator to terminal 7 for Motor 2.

CHECK THE MOTOR'S DIRECTION OF ROTATION

After you have connected the main power supply, one activating device, and the operator(s) to the control panel, you need to check the direction of rotation for each operator motor in your gate design.

To check a motor's direction of rotation, you must have three closed circuits on terminal block J3. Install one circuit between terminals 11 and 21, another circuit between 13 and 21, and another circuit (or stop device) between terminal 14 and 15.

You cannot check the motor's direction of rotation without these circuits (jumpers) or the accessories. When properly prepared for testing, the LEDs DL3, DL4, and DL5 should be illuminated.

WARNING! Running the operator—even for testing purposes—without a connected reversing device is potentially dangerous. Do not place yourself within the path of the moving gate during your test.

You also need to install a normally open activation device across terminals 18 and 19.

Disengage the operator(s) with the Manual Release key, and open the gate by hand about halfway.

Next, engage the operator(s) with the Manual Release key so that you can check the rotation of the motor(s).

Turn on the main power and send an activating signal to the operator(s). The gate leaf (or leaves) should open. If a gate leaf closes, then you need to turn off the main power and reverse the connection of the brown and black (or red and black) wires on terminal block J2 for the operator controlling that leaf. Then you need to recheck the rotation direction again.

If your gate system has two operators, be sure the motor of each rotates in the correct direction.

After having completed your test of the motor's direction of rotation, replace any test circuits you installed (between terminals 11 and 21, between 13 and 21, and between 14 and 15) with the proper reversing and stop devices. The instructions for installing such accessories follow.

CONNECT OTHER DEVICES

WARNING! Turn the main power off before you make any electrical connections or set any switches inside the control panel box.

Now you can connect additional reversing and activating devices to the control panel. Refer to Figure 11 for

the general control panel layout, and refer to Figure 9 for the layout of the terminal strip.

POWER SUPPLY FOR ACCESSORIES: You can access a 30 VDC output for supplying power to accessories that require DC voltage through terminals 9 and 10 (located above the label 30 Vcc) on terminal block J3. In most cases, this source can be used to power 24 VDC accessories.

NOTE: The 450 MPS control panel allows a maximum accessory load of 800 mA.

REVERSING DEVICES: Reversing devices include photobeams, inductive loops, and so forth. All of the reversing devices should have contacts of the normally closed (N.C.) type. Where you connect a device depends on whether you want the device to operate during opening or during closing.

Note: UL does not recognize the FAAC system with loop detectors or safety edges. FAAC photobeams must be used to comply with UL 325.

Caution: Failure of a reversing device that operates during opening causes a gate to lock in the closed position and requires the use of the Manual Release.

To wire photobeams, refer to Figure 9 (see FSWOP for opening photobeams, and FSWCL for closing photobeams— wire the photobeams exactly as shown). See Figure 11 for the wiring of a variety of common accessories. In either case, if you have multiple devices, wire them in series.

ACTIVATING DEVICE: The activating device for your gate must have normally open (N.O.) contacts. If you have a dual gate, connect devices to terminals 18 and 19. If you have a dual gate and want a particular device to open only one leaf, connect it to terminals 16 and 17.

DECODER CARD: If you are installing a FAAC radio receiver, a Digicard magnetic card reader, or a Digikey keypad, use the quick-fit connector J4 for the radio receiver or the DS (formerly the MD01) decoder card (see Figure 8).

NOTE: If you are using both a receiver and a decoder, hard wire the decoder and plug the receiver in.

OPEN/HOLD OPEN DEVICE: To open hold the gate open, you must use a latching switch wired to terminals 18 and 19.

STOP BUTTON: The stop button you install must have normally closed (N.C.) contacts. Multiple stop buttons must be wired in series. Connect your stop device between terminals 14 and 15.

THE LED INDICATORS: The five light-emitting diodes (LEDs) on the control panel can be used to check for the proper functioning of the devices you attach to the control panel. The LED lights are on whenever the contacts are closed across each of the respective terminals.

DL1 and DL2 should illuminate only when an activating signal is sent for 2 and 1 gate leaves, respectively. DL3 should be illuminated except when the stop button is pressed. DL4 and DL5 should be illuminated except when the reversing devices, for opening and closing, respectively, are triggered. Use the LEDs and the next table to determine if the accessory devices you have installed are operating properly.

LED	On	Off
DL1, A	Command active	Command inactive
DL2, B	Command active	Command inactive
DL3, Stop	Command not active	Command active
DL4, FTSW Open	Opening reversing devices not triggered	Reversing device triggered
DL5, FTSW Close	Closing reversing devices not triggered	Reversing device triggered

ELECTRIC LOCK: Connect your lock to the terminals 24 and 25. The terminals provide 12 VAC that pulses for 4 seconds whenever the gate starts to open. An electric lock can make use of the reversing stroke function controlled by DIP switch 5. A reversing stroke is a short closing phase that allows the electric lock time to disengage itself before the operator starts its opening. Turn DIP switch 5 on only if necessary for your lock to function correctly.

See Figure 11 for the wiring of a magnetic locking device.

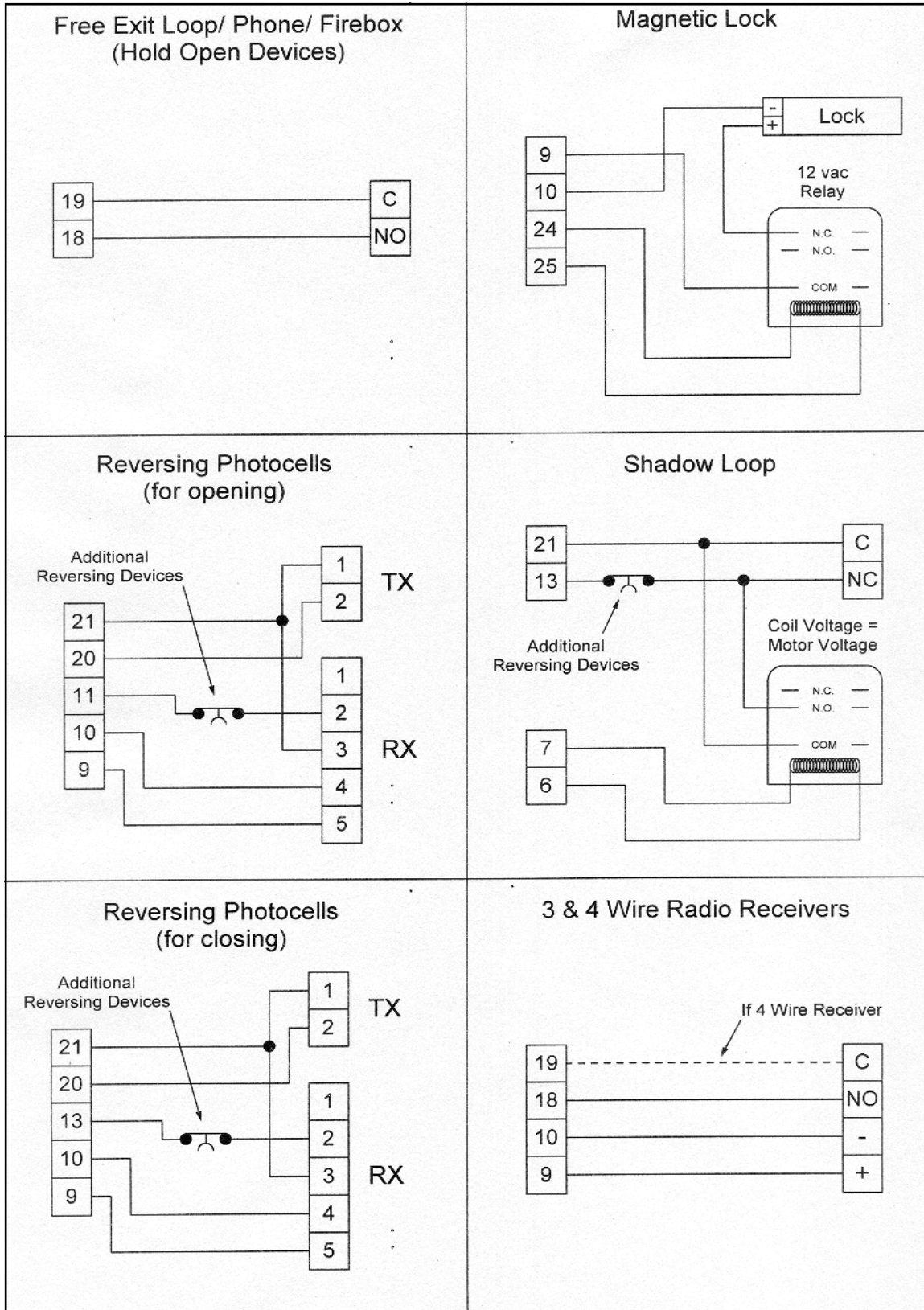

NO = Normally Open, NC = Normally Closed, C = Common, TX = Transmitter, RX = Receiver

Figure 11. Common Accessories wired to 450 MPS

WARNING LIGHT: Connect a warning light to terminals 22 and 23 in the group labeled *W.LIGHT* in terminal block J3. The terminals provide an output voltage of 30 VDC, maximum power 3 Watts. This output voltage will power most 24 VDC warning lights.

Note: The behavior of the warning light varies according to the logic you have set:

Logics A, S, E, EP, and B: The warning light is on steadily during opening and the pause phase. During closing, the light flashes.

Logic C: The warning light is on steadily during opening and flashes during closing.

SET OTHER OPERATING CONTROLS

WARNING! Turn off the main power before you make any electrical connections or set any switches inside the control panel box.

You need to set DIP switches and adjust the potentiometers on the control panel for your gate's operation. The 450 MPS Control Panel has 5 DIP switches and 4 potentiometers that control a wide range of functions.

SET DIP SWITCHES

Switches 1, 2, and 3 (Operating Logic): The 450 MPS Control Panel offers six operating modes: A, S, E, EP, B, and C. For more details about the logical modes, refer to the operating modes previously listed in this manual.

Switches 1, 2, and 3 control the operating logic according to the following scheme:

Logic	DIP Switch		
	1	2	3
A	on	off	on
S	on	off	off
E	off	on	off
EP	on	on	off
B	on	on	on
C	off	off	on

Switch 4 (Reversing Device Behavior on Closing): Refer to the operating logic tables earlier in these instructions and to the following table for how to set DIP switch 4.

Gate Behavior During Closing	DIP Switch 4
Gate immediately reverses its direction	off
Gate stops and reverse its direction when reversing device is no longer triggered	on

SWITCH 5 (REVERSING STROKE): Sometimes electric locks require a reversing stroke to disengage the lock. If your gate does not always open because your lock is hanging up, you may want to activate the Reversing Stroke.

Reversing Stroke	DIP Switch 5
Not activated	off
Activated	on

Adjust the Potentiometers

The four potentiometers control the torque, the pause time, the opening/closing time of operation, and the leaf delay on closing.

TORQUE: The torque potentiometer on the 450 MPS **must** be turned all the way clockwise for the 422 Operator. The potentiometer is for the FAAC Model 412, a screwdrive operator. The torque potentiometer cannot be used to adjust the operator's hydraulic operating pressures.

CAUTION: Failure to turn the torque potentiometer to maximum in the clockwise direction jeopardizes the life of the motor of your operator.

WARNING! Adjust the operating pressure on the 400 Operator only by means of the hydraulic bypass valve screws. See pages 11 and 19.

PAUSE TIME: The pause time between opening and closing can be adjusted from 0 to 240 seconds. Turn the potentiometer clockwise to increase the pause time and counterclockwise to decrease the pause time.

OPENING/CLOSING TIME: The opening/closing time is adjustable from 10 to 62 seconds. The approximate opening/closing time for a 90-degree opening is about 12 seconds. Turn the potentiometer clockwise to increase the time and counterclockwise to decrease the time.

For optimal operation, set the time so that the motor remains active for a couple of seconds after the leaf has reached its limit stop for opening and for closing.

LEAF DELAY: You may choose to delay one leaf on closing for overlapping gate leaves. Be sure the operator on the leaf for delayed closing is connected to Motor 1. On opening, the leaf connected to Motor 2 is delayed 2.5 sec.

Note: You cannot *adjust* this opening delay of the operator connected to Motor 2. However, you can turn off the delay by closing the jumper labeled "Leaf Delay Disable".

The closing leaf-delay time is adjustable from 0 to 28 seconds. Turn the potentiometer clockwise to increase the time and counterclockwise to decrease the time.

Note: If one-leaf gate designs, be sure to set the potentiometer for leaf delay to its minimum (0 seconds).

Note: If the opening/closing time is set at less than the leaf delay time, the delayed leaf closes at the end of the closing time.

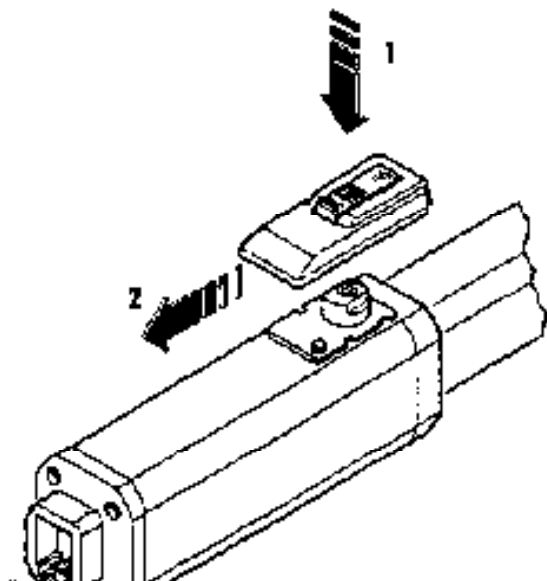

Figure 16. Install the locking cap cover

BLEED THE OPERATOR

Air bubbles in hydraulic fluid cause erratic performance in a hydraulic system, so you must rid the 400 Operator of that air to insure smooth operation.

If you have removed the vent screw, the 400 operator should bleed itself. Running the operator should remove any air from the system. If the operator runs

smooth throughout the swing, no attempt to further bleed the unit is necessary.

If the operator runs erratic, perform 10 bleeding operations. One bleeding operation consists of automatically opening and closing the gate and then pausing for two minutes. The 2-min pause allows the air bubbles to escape through the vent screw hole.

MAINTENANCE

THE 400 OPERATOR

The FAAC recommended maintenance schedule varies according to the frequency of use of the operators, whether lightly used operators (once or twice an hour) or heavily used operators (many cycles per hour). Operators used in a humid/ salt air climate should follow the heavy duty use schedule.

Check the oil.

To check the oil level correctly, remove the locking cap from the operator. The operator should be at least half full.

Note: You will not be able to see the oil level. Use something flexible (i.e. A piece of stranded wire) to act as a dipstick.

If the operator is too full, it will bleed oil out the vent hole.

Light duty use: check once per year
Heavy duty use: check every 6 mo

Change the oil.

Changing the oil requires removing the operator from its installed position. Remove the locking cap and drain the oil out of the hole under the cap. Refill the operator with the proper new oil (see page 4).

Light duty use: change every 4 yr
Heavy duty use: change every 2 yr

Check the pressure settings.

Light duty use: check once per year
Heavy duty use: check every 6 mo

THE CONTROL PANEL

Keep the control panel free from spider webs, insects, etc. Otherwise, the control panel requires no maintenance.

TROUBLESHOOTING

WARNING! Before you do any work on the control panel, be sure to turn off the main power.

NOTE: Any control panel specific information in the following applies to the 450 MPS control panel only.

PROBLEM: THE GATE DOES NOT RESPOND TO AN ACTIVATING SIGNAL.

SOLUTION:

You should have at least one operator wired to terminals 3, 4, and 5.

Be sure that you have the motor start capacitors wired in with the directional leads. See Figure 9.

Be sure that the torque potentiometer is turned all the way clockwise.

Verify that the LEDs DL3, DL4, and DL5 are illuminated. If they are not illuminated, be sure that you have closed circuits in the stop and reversing input terminals as shown in Figure 9.

Verify that your activating device works properly. DL1 should illuminate when you signal the gate to open. If DL1 does not illuminate when you signal the gate, then the problem may be in your activating device. Short across terminals 18 and 19. If the short causes the gate to open, then the problem is in the activating device. Repair or replace the device.

PROBLEM: THE GATE DOESN'T OPEN (OR CLOSE) THOUGH THE MOTORS ARE RUNNING.

SOLUTION:

Make sure that the motor is running in the right direction, and make sure the Manual Release mechanism has fully engaged the hydraulic system.

Increase the bypass pressure in small 1/4 turn increments to see if the hydraulic system needs more pressure.

PROBLEM: THE GATE OPENS BUT DOES NOT CLOSE.

SOLUTION:

Make sure you have selected the desired operating mode.

Verify that the reversing devices are working properly. DL4 and DL5 should be illuminated except when a reversing device is triggered. If either does not illuminate, then one of your reversing devices is preventing the gate from responding to your signal.

Check your reversing devices.

If no reversing devices are installed, make sure a circuit is installed between appropriate terminals.

PROBLEM: THE GATE DOES NOT FULLY OPEN (OR CLOSE).

SOLUTION:

Increase the bypass pressure(s) to see if the hydraulic system needs more pressure.

Check the operator's open/ close time selection. You should set a time that is just longer than the rated speed of your model of operator. For example, because the 422 CBAC has a rated opening time of 12 sec, you should set the time at 19 or 20 seconds.

Check to see that there are no obstructions in the path of the gate or that the hinges are not binding.

PROBLEM: THE OPERATOR DOESN'T WORK SMOOTHLY AND THE GATE JERKS AS IT OPENS AND CLOSSES.

SOLUTION:

Check the oil level in the operator.

Make sure the Manual Release mechanism has fully engaged the hydraulic operation of the operator.

Bleed the air from the hydraulic system. (See page 20)

Make sure that a flexible gate leaf is not the problem. If the gate leaf flexes, then stiffen the gate or use a slower operator.

PROBLEM: THE GATE DRIFTS OPEN OR CLOSE WHEN THE MOTOR IS NOT RUNNING.

SOLUTION:

Remove the manual release valve, located next to the pressure adjustment screws, with a 6mm hex key. Be sure that the white ring and the o'ring are not damaged. If not damaged, there may be internal damage and a seal kit will be needed to rebuild the unit.

EXPLODED VIEW, 400 CBAC

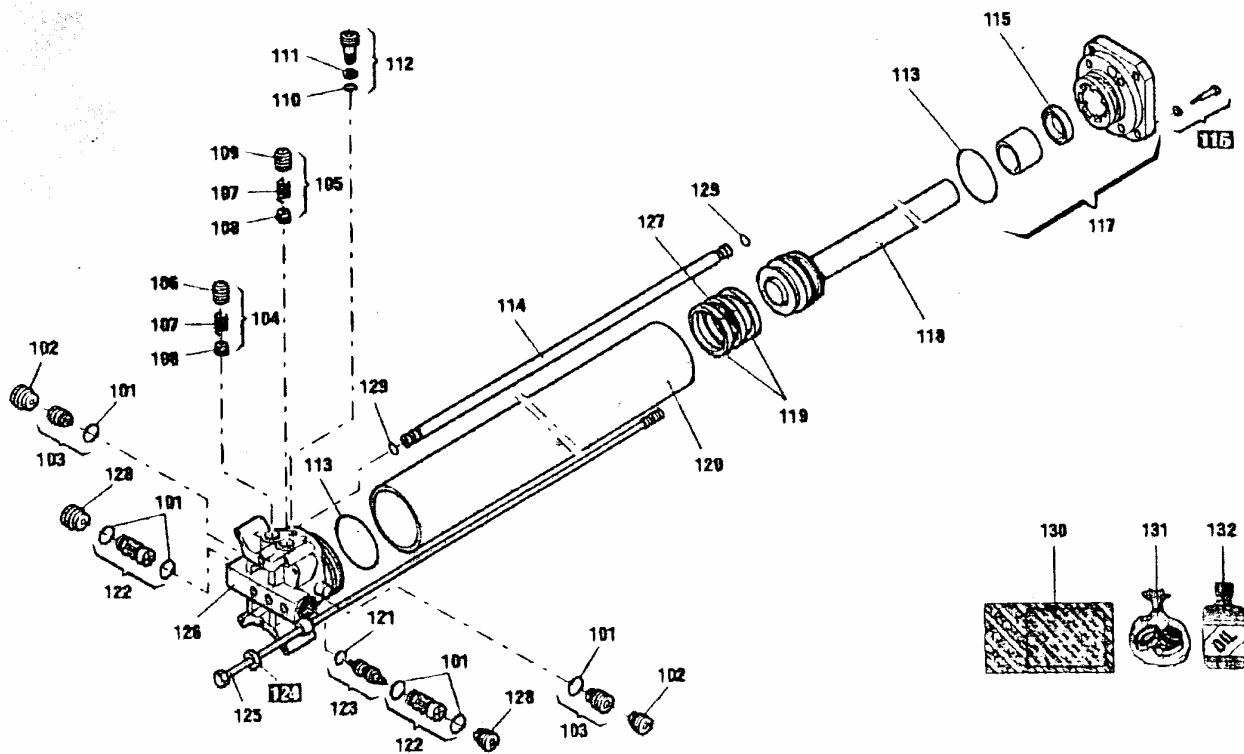
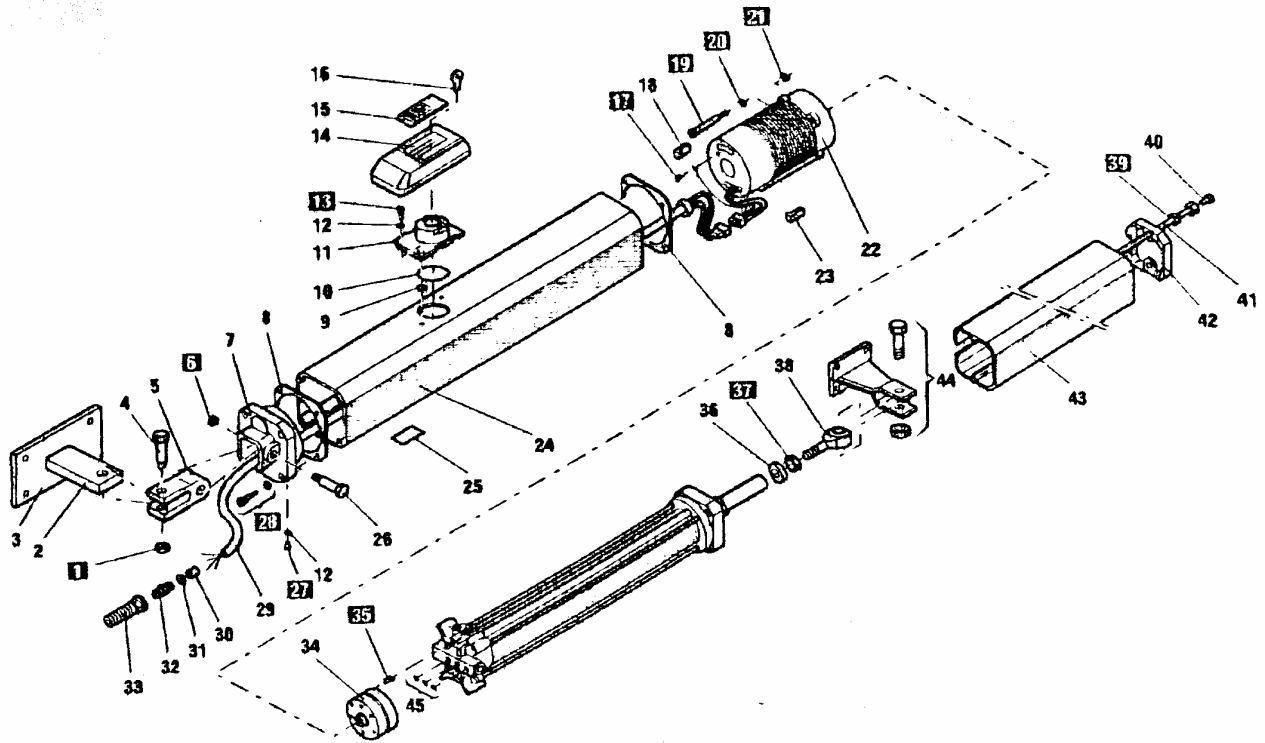

400 PARTS LIST

POS	PART NO.	DESCRIPTION	QTY
1	2036	Galvanized Nut (8mm)	1
2	7220015	Rear Bracket	1
3	7284005	Rear Bracket Plate	1
4	7182075	Short Pin	1
5	7221115	Rear Fork	1
6	2037	Self-Locking Nut (8mm)	1
7	7170865	Rear Flange	1
8	7099101	Gasket (D80)	2
9	7090440	O-Ring Locking Cap (Small)	2
10	7090655	O-Ring Locking Cap (Center)	1
11	41850215	Locking Cap	1
12	7094065	Gasket (copper)	3
13	2274	Vent Screw (4x6mm)	3
14	7270805	Locking Cap Cover	1
15	7270815	Access Slide (Locking Cap)	1
16	7131005	Viro Key (Manual Release)	1
17	N/A	Self Threading Screw (4mm)	1
18	7119475	Vibration Dampener	2
19	2365	Motor Bolt (4X50mm)	4
20	2366	Lock Washer (4mm)	4
21	2367	Hex Nut (4mm)	4
22**	77000425	115V 1400 RPM Motor	1
23	7119485	Vibration Dampener	2
24	309003	Operator Body	1
25	N/A	Vent Screw Label	1
26	7182175	Long Pin	1
27	2274	Vent Screw (4x6mm)	3
28	N/A	Torx (Self Threading) T20	8
29	7514055	Electric Power Cord	1
30*	2581	Fiber Washer	1
31*	7039305	Strain Relief Brass Washer	1
32*	7109155	Strain Relief Nut	1
33*	7109145	Strain Relief	1
34	3204395	1Lt Lobe Pump	1
35	N/A	Pump Pin (4X28mm)	2
36	7039025	Washer (Swivel)	1
37	702201	Swivel Jam Nut (10mm)	1
38	7073025	Swivel Joint	1
39	N/A	Star Washer (5mm)	2

POS	PART NO.	DESCRIPTION	QTY
40	7119405	Protective Cover End Cap Plug	2
41	7019195	Tie-Rod (Protective Cover)	2
42	4170015	Protective Cover End Cap	1
43	7272105	Protective Cover	1
44	7220355	Front Mounting Bracket	1
45	7090010015	O-Ring	3
101	7090010015	O-Ring	5
102	7049135	Valve Retainer	2
103	4404065	Inlet Valve	2
104	4180035	Red By-Pass Cap Assembly	1
105	4180045	Green By-Pass Cap Assembly	1
106	7119015	By-Pass Cap (Red)	1
107	7210025	By-Pass Spring	2
108	7310315	By-Pass Cap	2
109	7119115	By-Pass Cap (Green)	1
110	7090280015	O-Ring Retract Tube (Short)	3
111	7043055	Extrusion Ring	1
112	4180195	Manual Release	1
113	7090360	O-Ring (Valve Body)	1
114	7361335	Retract Tube	1
115	N/A	O-Ring Front Flange (Internal)	1
116	N/A	Torx (Self Threading) T20	8
117	4994265	Front Flange	1
118	4350105	Piston Assembly	1
119	7091015	Piston Rod Packing	2
120	7366025	Cylinder	1
121	7090300	O-Ring (Shuttle Piston)	1
122	4404085	Lock Valve	2
123	4180285	Shuttle Piston	1
124	N/A	Star Washer (5mm)	4
125	7230295	Tie-Rod (Cylinder)	4
126	4994345	Valve Body (CBAC)	1
127	N/A	Guide Ring (Piston)	1
128	7049005	Valve Retainer (Brass)	2
129	7090675	O-Ring (Retract Tube)	2
130	3905265	Skin Pack	1
131	2167*	Seal Kit	1
132	6105	1 Qt Monolec Oil	1

* Included in Kit #2167A*

* * 220V 1400RPM Motor Part #77000415

LIMITED WARRANTY

To the original purchaser only: FAAC International, Inc., warrants, for twenty-four (24) months from the date of invoice, the gate operator systems and other related systems and equipment manufactured by FAAC S.p.A. and distributed by FAAC International, Inc., to be free from defects in material and workmanship under normal use and service for which it was intended *provided* it has been properly installed and operated. FAAC International, Inc.'s obligations under this warranty shall be limited to the repair or exchange of any part of parts manufactured by FAAC S.p.A. and distributed by FAAC International, Inc. Defective products must be returned to FAAC International, Inc., freight prepaid by purchaser, within the warranty period. Items returned will be repaired or replaced, at FAAC International, Inc.'s option, upon an examination of the product by FAAC International, Inc., which discloses, to the satisfaction of FAAC International, Inc., that the item is defective. FAAC International, Inc. will return the warranted item freight prepaid. The products manufactured by FAAC S.p.A. and distributed by FAAC International, Inc., are not warranted to meet the specific requirements, if any, of safety codes of any particular state, municipality, or other jurisdiction, and neither FAAC S.p.A. or FAAC International, Inc., assume any risk or liability whatsoever resulting from the use thereof, whether used singly or in combination with other machines or apparatus.

Any products and parts not manufactured by FAAC S.p.A. and distributed by FAAC International, Inc., will carry only the warranty, if any, of the manufacturer. This warranty shall not apply to any products or parts thereof which have been repaired or altered, without FAAC International, Inc.'s written consent, outside of FAAC International, Inc.'s workshop, or altered in any way so as, in the judgment of FAAC International, Inc., to affect adversely the stability or reliability of the product(s) or has been subject to misuse, negligence, or accident, or has not been operated in accordance with FAAC

International, Inc.'s or FAAC S.p.A.'s instructions or has been operated under conditions more severe than, or otherwise exceeding, those set forth in the specifications for such product(s). Neither FAAC S.p.A. or FAAC International, Inc., shall be liable for any loss or damage whatsoever resulting, directly or indirectly, from the use or loss of use of the product(s). Without limiting the foregoing, this exclusion from liability embraces a purchaser's expenses for downtime or for making up downtime, damages for which the purchaser may be liable to other persons, damages to property, and injury to or death of any persons. Neither FAAC S.p.A. or FAAC International, Inc., assumes nor authorizes any person to assume for them any other liability in connection with the sale or use of the products of FAAC S.p.A. or FAAC International, Inc. The warranty hereinabove set forth shall not be deemed to cover maintenance parts, including, but not limited to, hydraulic oil, filters, or the like. No agreement to replace or repair shall constitute an admission by FAAC S.p.A. or FAAC International, Inc., of any legal responsibility to effect such replacement, to make such repair, or otherwise. This limited warranty extends only to wholesale customers who buy directly through FAAC International, Inc.'s normal distribution channels. FAAC International, Inc., does not warrant its products to end consumers. Consumers must inquire from their selling dealer as to the nature and extent of that dealer's warranty, if any.

This warranty is expressly in lieu of all other warranties expressed or implied including the warranties of merchantability and fitness for use. This warranty shall not apply to products or any part thereof which have been subject to accident, negligence, alteration, abuse, or misuse or if damage was due to improper installation or use of improper power source, or if damage was caused by fire, flood, lightning, electrical power surge, explosion, wind storm, hail, aircraft or vehicles, vandalism, riot or

FAAC International, Inc.
303 Lexington Avenue
Cheyenne, WY 82007
www.faacusa.com