



Not UL325 compliant

Operating Instructions



This product is an accessory or part of a system. Always read and follow the manufacturer's instructions for the equipment you are connecting this product to. Comply with all applicable codes and safety regulations. Failure to do so may result in damage, injury or death!

Product Overview

The BPE-50 photo beam system uses 12 -24 VDC/AC on the transmitter and receiver with the transmitter offering the option of using the two 3.6 Volt batteries for power (included). Recommended battery replacement is the Varta ERAA 3V6 2400.



WARNING ... Not to be used for Personnel Protection
 Never use product as sensing devices for personnel protection. Doing so could cause serious injury or death.
 These sensors do NOT include the self-checking redundant circuitry necessary to allow their use in personnel safety applications. A sensor failure or malfunction can cause either an energized or de-energized sensor output condition. UL 325 Non-compliant

Technical Specifications

Power Supply	12-24 VDC 24 VAC (2-3.6 Volt Lithium Batteries for transmitter optional /included) Expected battery life up to 2 years approx.
Current Draw	RX = <50mA standby 100mA activated, TX = < 500uA
Relay Type	2 Form C DPST contact rating .5A @ 24VDC / 120VAC
Temperature	-20C - 55C
Wavelength	880 nm
Frequency	High 90 Hz Low 48 Hz (Ext power 787 Hz)
Environmental	IP 65
Detect Indicator	Red LED
Connector	Terminal block
Relay contact	0.5Amp
Housing Material	PA6 30% FG
Size	H 4.4in (112mm) x W 2.05in (52mm) x D 1.3in (33mm)
Range	Up to 50 feet (if TX on 12/24 V 90 feet)
Detection Angle	+/- 5%
Sensitivity	Jumper J1 on receiver
Detection delay	< 30 ms
Reset delay	< 120 ms

Connections (Fig 1)

	Transmitter	Receiver
1	Power Positive (+)	Power Positive (+)
2	Power Negative (-)	Power Negative (-)
3	NC Security Contact (join if not used)	Internal Relay Normally Open
4	Security edge (join if not used)	Internal Relay Common
5	Security edge (join if not used)	Internal Relay Normally Closed Output

Terminal connection as viewed from the front, left to right

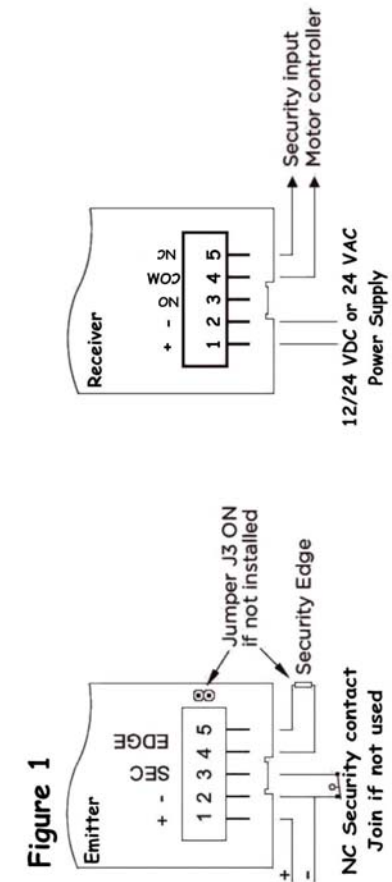

Jumper Configuration (Fig 2)

Jumper	ON	OFF
Receiver J1 (Gain)	Normal	High
Transmitter J2 (frequency)	Fast	Slow
Transmitter J3 (Security edge)	Not connected	Connected

Jumper Settings for figure 2

Figure 2

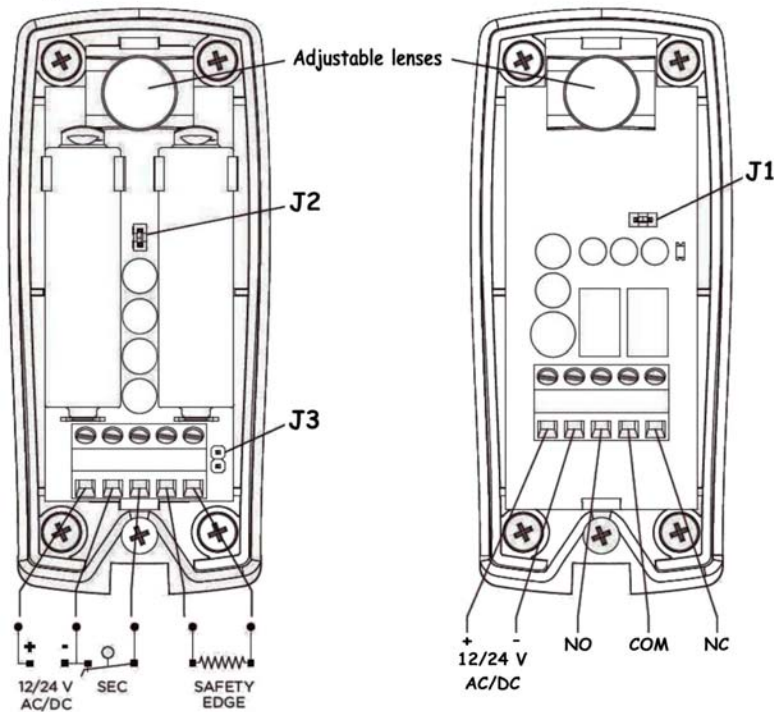

When transmitter frequency is set to low battery life will be increased. The range will be reduced at this setting. However when the transmitter is powered by 12/24 VDC or 24 VAC the range will be maximum regardless of the jumper setting.

Lens Alignment (Fig 3)

Both the transmitter and receiver lenses may be aligned left, right or straight ahead. To align gently pull the lens stem straight out from mounting position and snap back into place pointing in the desired direction.

Figure 3



Units should be placed a minimum of 12 – 16 inches from the floor. Across from and lenses facing each other. The receiver red detect LED will be on when the beam is broken or not aligned.



4564 Johnston Parkway
Cleveland, Ohio 44128
United States of America

WEB <http://www.emxinc.com>

Technical Support Telephone (216) 834-0761
E-mail technical@emxinc.com

Sales Telephone (216) 518-9888
Fax (216) 518-9884
Email salesupport@emxinc.com



Installation (Fig 4)

Place the BPE-50 away from heat and electromagnetic sources for best operation. Mount units a minimum of 12 inches 30 cm from the floor.

Apply power to the units and set jumpers per instruction on see figures 1 and 2.

Test installation to insure desired and proper operation. All local and operator manufacturer installation instructions should be followed.

The BPE-50 transmitter may be hooked up to an edge sensor for alternative activation operation.

The BPE-50 does not require any special care, but it is necessary to check condition occasionally to insure they are operating correctly. (Batteries are still operational if on battery power)

Recommended battery replacement is the Varta ERAA 3V6 2400.

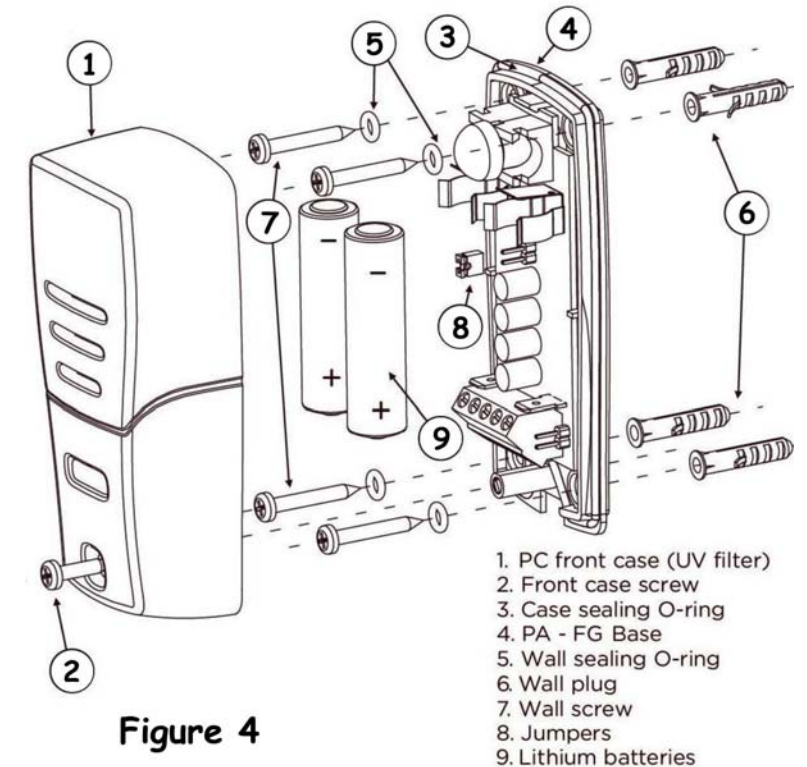

Figure 4