

Overview

The Wireless Pedestrian & Vehicle Sensor is a Passive Infra-Red sensor that detects movement of people and vehicles, while allowing small animals to pass through undetected. Each PIR Motion Sensor has its own unique ID, for a secure radio link. Base Station (not provided) can learn the signals of up to four PIR Motion Sensors. The Base Station will give a single beep for the first Sensor that it learns, a double beep for the second, and so forth. Additionally, multiple Base Stations can work with the same PIR Motion Sensor to sound in different places.

Carton Inventory

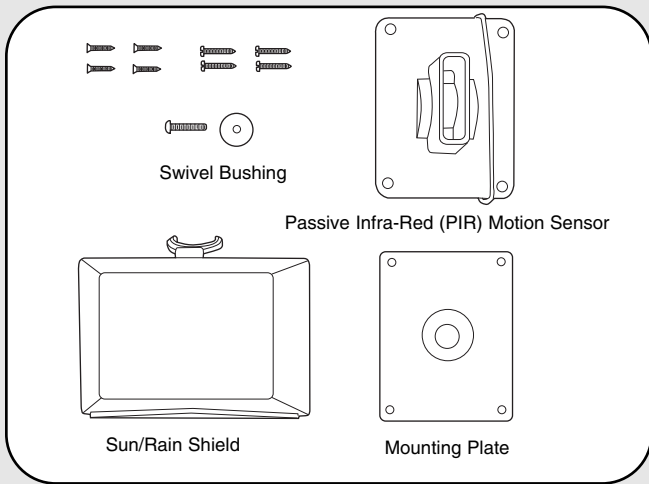

PIR Motion Sensor Assembly & Test

Step 1

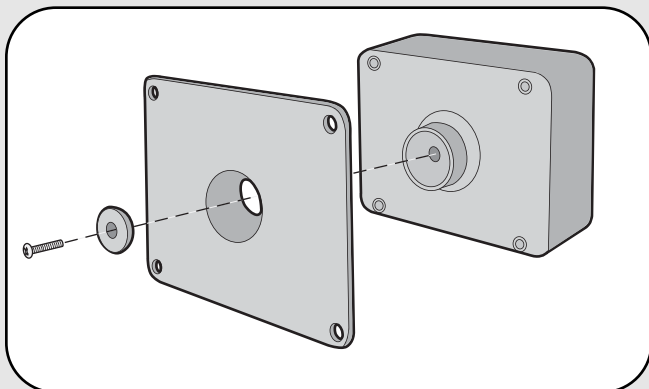

Attach PIR Motion Sensor box to mounting plate with large silver screw. Tighten screw until PIR Motion Sensor stays in place when repositioned.

Step 2

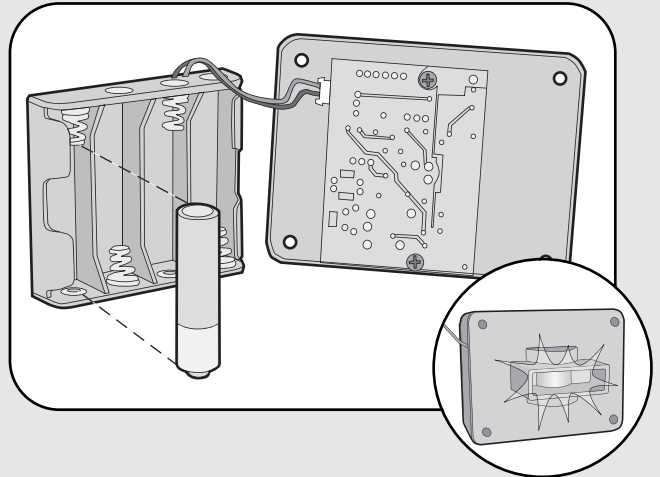

Install 4 AA Alkaline batteries (not provided). (Lithium batteries recommended for colder environments.) LED light will flash.

Switch Settings

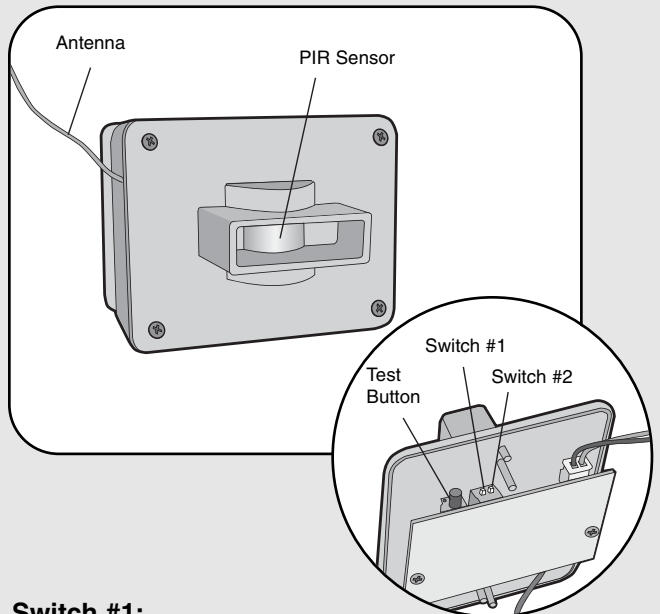

Switch #1:

OFF	15' Detection Range
ON	30' Detection Range (Default)

Switch #2:

OFF	Low Sensitivity
ON	High Sensitivity (Default)

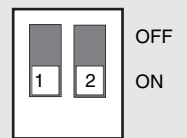

NOTE: To avoid unwanted detection of small animals move Switch #2 to OFF.

Step 3

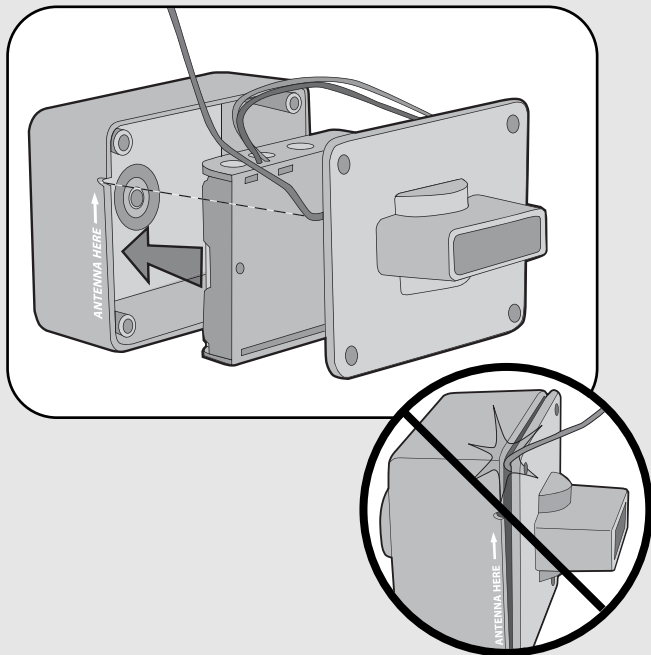

Insert battery pack facing away from circuit board and attach cover.

NOTE: Ensure the batteries do not touch the circuit board and the antenna and battery wires are not pinched.

Step 4

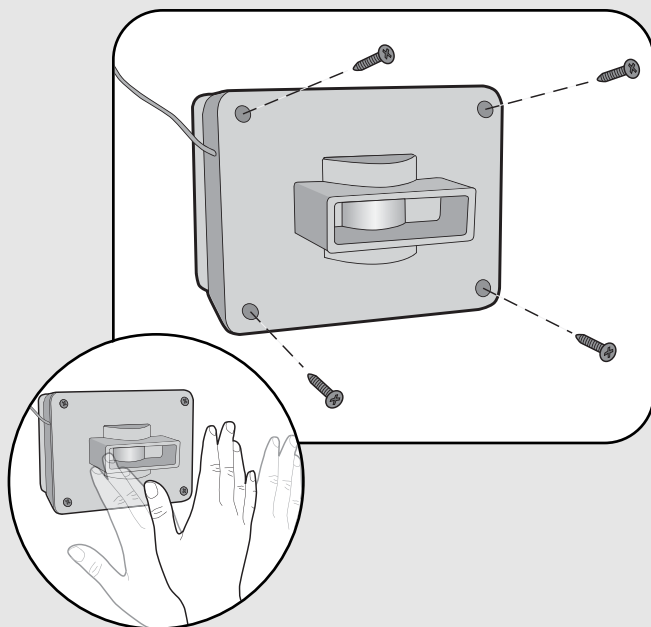

Test PIR Motion Sensor by waving hand in front of sensor. Test light should flash. Secure cover with the smallest screws.

Programming PIR Motion Sensor to Base Station

Step 5

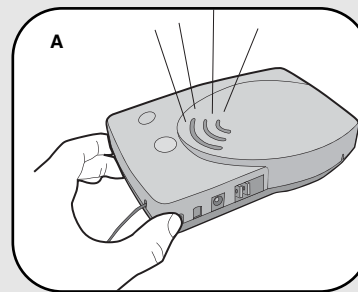

A Ensure Base Station and PIR Motion Sensor are in close proximity to each other. Press and release learn button on Base Station. Buzzer will sound.

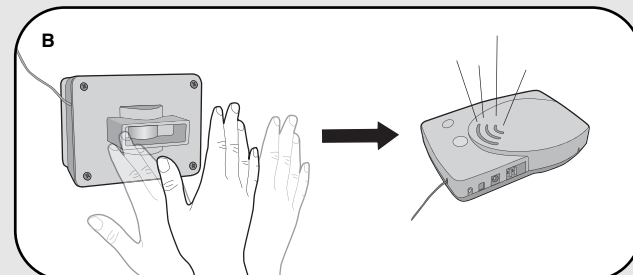

B Within 5 seconds, wave hand in front of PIR Motion Sensor. Test light will illuminate and Base Station will buzz.

PIR Motion Sensor Installation

Step 6

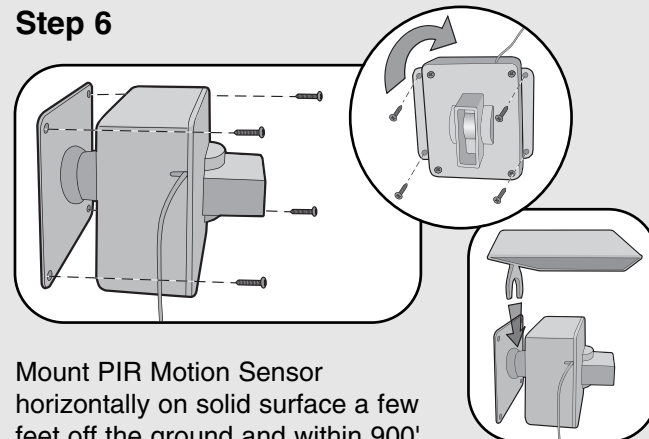

Mount PIR Motion Sensor horizontally on solid surface a few feet off the ground and within 900' of Base Station (rotate sensor to access screw holes). Unit should be able to swivel as needed. Attach sun/rain shield.

NOTE: Keep PIR Motion Sensor antenna away from metal objects. Do not mount PIR Motion Sensor in direct sunlight, near moving tree branches, or in the path of a sprinkler system.

Vehicle Alert Installation: For cars, the best mounting position is about 4' high, between 10-20' back, and angled to see the back of car after passing the sensor.

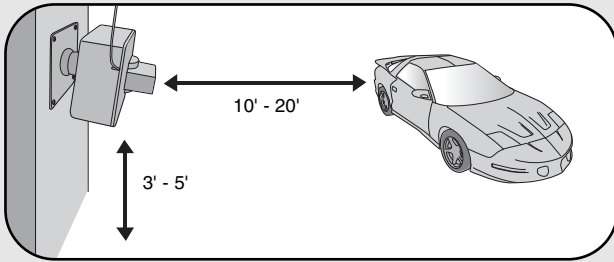

Troubleshooting

The PIR Motion Sensor lights up, but the Base Station does not respond.

The PIR Motion Sensor must be programmed to Base Station (See Step 5).

Ensure Base Station is on and is not muted.

If the green power light is not lit or is flashing, press the Mute Button on the top of the Base Station to wake it up.

If the green power is illuminated, look at the two small white Base Station switches next to the Learn Button.

The #1 Dip Switch should be down, towards the circuit board. If it is up, the Base Station has been muted. If the Base Station signals when you press the Learn Button, it is not muted.

PIR Motion Sensor is detecting motion only part of the time.

To detect cars, it is best to mount PIR Motion Sensor at height of car's motor and have it between ten and twenty feet from the road. Swivel sensor as needed.

The Alert is giving false alarms.

Check for moving tree branches or insects in sensor window. PIR sensor can also be triggered by light shining directly in sensor window, such as reflected sunlight, or motion in front of a light source.

It is possible that condensation has built up on the sensor. Wipe condensation from PIR Motion Sensor with cotton swab. Let it sit inside for a few hours, open to the air, without the batteries and it should correct itself.

Check Sensor Switches on PIR Motion Sensor. See *Switch Settings*.

Base Station beeps every ten minutes.

The battery in the Base Station is low. Replace with 9-Volt battery or operate it using AC Adapter.

The Alert is not getting expected transmission range.

Keep both antennas vertical and keep PIR Motion Sensor antenna away from trees and metal objects.

Ensure Base Station is in clearest possible sight of the PIR Motion Sensor. The less objects between the devices, the longer the range.

Base Station is not very loud.

An accessory such as a bell, buzzer, or light can be attached to the relay switch. The relay switch can handle up to 120 AC volts at 10 amps. The accessory device will need a separate power supply.

The accessories can be purchased at any electronics store.

NOTE: *The manufacturer is not responsible for any radio or TV interference caused by unauthorized modifications to this equipment. Changes or modifications not expressly approved by the manufacturer could void the user's authority to operate the equipment.*

FOR TECHNICAL SUPPORT DIAL OUR TOLL FREE NUMBER:

1-800-528-9131

www.chamberlain-DIY.com

NOTICE: To comply with FCC and or Industry Canada rules (IC), adjustment or modifications of this receiver and/or transmitter are prohibited, except for changing the code setting or replacing the battery. THERE ARE NO OTHER USER SERVICEABLE PARTS.

Tested to Comply with FCC Standards FOR HOME OR OFFICE USE. Operation is subject to the following two conditions: (1) this device may not cause harmful interference, and (2) this device must accept any interference received, including interference that may cause undesired operation.