

MBar / LBar

Automatic barrier

M3BAR

M5BAR

M7BAR

LBAR



CE 0682

EN - Instructions and warnings for installation and use

IT - Istruzioni ed avvertenze per l'installazione e manuale per l'uso

FR - Instructions et avertissements pour l'installation et l'utilisation

ES - Instrucciones y advertencias para la instalación y el uso

DE - Installierungs-und Gebrauchsanleitungen und Hinweise

PL - Instrukcje i ostrzeżenia do instalacji i użytkowania

NL - Aanwijzingen en aanbevelingen voor installatie en gebruik

Nice

Contents

1 - WARNINGS AND GENERAL PRECAUTIONS	1
1.1 - Safety instructions	1
1.2 - Installation warnings	1
1.3 - Special warnings related to European Directives applicable to the product	1
1.3.1 - Installation criteria and special warnings related to essential requirements	2
2 - PRODUCT DESCRIPTION AND INTENDED USE	3
3 - INSTALLATION	3
3.1 - Preliminary checks for installation	3
3.2 - Product application limit	3
3.2.1 - Product durability	3
3.3 - Preliminary work prior to installation	4
3.3.1 - Identify the scheme on the basis of which to position each plant component	4
3.3.2 - Determine the path of the connecting cables	4
3.3.3 - a) - Position the balancing spring in relation to pole weight, complete with the required accessories. b) - Set the direction for closing the pole: to the right or to the left of the motor	4
3.4 - Barrier lift fixture	4
3.4.1 - If the support surface already exists	4
3.4.2 - If the support surface does not exist	4
3.5 - Installing the rod and the accessories provided	5
3.5.1 - Pole support assembly	5
3.5.2 - Assembling a pole formed of a single piece, whole or cut	5
3.5.3 - Assembling a pole formed of two pieces, either whole or cut	6
3.5.4 - Installation of required pole accessories	6
3.6 - Manually releasing and locking the barrier	6
3.6.1 - How to move the locking cylinder for manual release and lock	6
3.7 - Limit switch mechanical stop adjustment	6
3.8 - Pole balancing	6
3.8.1 - M3BAR / M5BAR / M7BAR Pole balancing	6
3.8.2 - LBAR Pole balancing	6
4 - ELECTRICAL CONNECTIONS	6
4.1 - Description of the electrical connections	6
4.2 - Initial start-up and electrical connections	7
4.3 - Pre-set functions	7
4.4 - Recognition of the connected devices	7
4.5 - Recognition of limit positions on opening and closing	7
4.6 - Pole movement check	7
4.7 - Connecting a radio receiver	8
4.8 - Connecting the pole lights (optional accessory)	8
4.9 - Connecting the LED flashing light mod. XBA7 or traffic light to LED mod. XBA8 (optional accessories)	8
4.10 - Connection of other devices	8
4.10.1 - Programming unit Overview	8
4.10.2 - Buffer battery mod. PS224 (accessory)	8
4.10.3 - Solemyo System (photovoltaic supply)	8
5 - TESTING AND COMMISSIONING	9
5.1 - Testing	9
5.2 - Commissioning	9
6 - CONTROL UNIT PROGRAMMING	10
6.1 - Level one programming (ON-OFF functions)	10
6.2 - Level two programming (adjustable parameters)	10
7 - FURTHER INFORMATION	12
7.1 - Total deletion of control unit memory	12
7.2 - Other functions	12
7.3 - Adding or removing devices	13
7.3.1 - Bluebus Inlet	13
7.3.2 - Photocells	13
7.3.3 - MOTB digital selector and proximity reader for MOMB transponder cards	13
7.3.4 - STOP Input	13
7.4 - Diagnostics	14
7.4.1 - Signals of control unit	14
7.4.2 - Flashing light signals	16
7.5 - Loop Detector	16
7.5.1 - Operation	16
7.5.2 - Installation	16
7.6 - Master - Slave mode	18
7.6.1 - Installation and electrical connections	18
8 - WHAT TO DO IF... (troubleshooting guide)	19
• Product disposal	19
• Technical characteristics of the product	20
• Declaration of Conformity: appendix I (removable appendix)	21
• Declaration of Conformity: appendix II (removable appendix)	22
• Operation manual (removable appendix)	23
• Maintenance schedule (removable appendix)	25
PICTURES	I - XIX

1.1 - Safety instructions

- **CAUTION! – This manual contains important instructions and warnings for personal safety.** Incorrect installation could cause serious physical injury. We recommend that you read this entire manual with care before starting any work. If in doubt, do not install the product and contact the Nice technical assistance department.
- **CAUTION! – Important instructions: keep this manual in a safe place to enable future product maintenance and disposal operations.**

1.2 - Installation warnings

- Before commencing installation, check that the product is suitable for the intended kind of use (see paragraph 3.1 and 3.2). If not suitable, do NOT proceed with installation.
- The contents of this manual refer to a standard system such as that shown in **fig. 1**.
Considering the risk situations that may arise during installation phases and use of the product, the automation must be installed in observance of the following warnings.
 - On the power line to the system, install a device for disconnection from the power mains with a gap between contacts that assures complete disconnection in the conditions of overvoltage category III.
 - All product installation and maintenance operations must be performed with the automation disconnected from the power mains. If the power disconnect device is not visible from the location of the automation, before starting working, a suitable notice must be affixed on the power disconnect device stating "WARNING! MAINTENANCE IN PROGRESS".
 - Connect the product to an electric power line equipped with an earthing system.
 - During installation, handle the automation with care to avoid crushing, impact, dropping or contact with liquids of any type. Never place the product near sources of heat or expose to naked flames. This may damage product components and cause malfunctions, fire or hazardous situations. If this occurs, suspend installation immediately and contact the Nice Service Centre.
 - Never make modifications to any part of the product. Operations other than as specified can only cause malfunctions. The manufacturer declines all liability for damage caused by makeshift modifications to the product.
 - This product is not designed to be used by persons (including children) whose physical, sensorial or mental capacities are reduced, or with lack of experience or skill, unless suitable instructions regarding use of the product have been provided by a person responsible for safety.
 - The product may not be considered an efficient system of protection against intrusion. If an efficient protection system is required, the automation must be integrated with other safety devices.
 - Do not allow children to play with fixed control devices. Keep remote control devices out of reach of children.
 - The road barrier cannot be used before it has been commissioned as specified in chapter 5 "Testing and commissioning".
 - The product's packaging materials must be disposed of in full compliance with local regulations.

1.3 - Special warnings related to European Directives applicable to the product

- **"Construction Products" Directive:**
Special warnings related to 89/106/EEC "Construction Products" Directive and subsequent modification 98/38/EEC applicable to the product:
 - Complete installation of this product, as described in this instruction manual and for certain types of use (for example excluding exclusive use for vehicles) may class it in the field of application of the Directive "Construction Products" 89/106/EEC and relative harmonised standard EN 13241-1.
 - Paragraph 1.3.1 specifies all installation criteria required to ensure that the product complies with the essential requirements of the directive 89/106/EEC; the installer should check and ensure that all these criteria are strictly observed.
 - Failure to observe one or more of these criteria may mean that the road barrier may not meet all the essential requirements. **Use of the product in these situations is strictly prohibited until all the directive requirements are met;** in this case, the label "ES13241-1.4870" applied on the product must be removed and the "EC declaration of Conformity" in appendix I of this manual may not be used. As a consequence, the installer in turn becomes the manufacturer of the "automatic barrier", and must therefore observe all the requirements of the Directive "Construction Products" 89/106/EEC and relative harmonised standard EN 13241-1. In this case the road barrier must be considered as "any machine" and the "Declaration of conformity" in appendix II may be used (for insertion in the technical documentation).
- **"Machinery Directive":**
 - Paragraph 1.3.1 specifies all installation criteria required to ensure that the product complies with the essential requirements of the "Machinery directive" 2006/42/EC (ex 98/37/EC). The installer should check and ensure that all these criteria are strictly observed.
 - Failure to observe one or more of these criteria may mean that the road bar-

rier may not meet all the essential requirements. **The use of the product is prohibited in these situations until the correspondence to the requirements of the directive has been verified by those performing the installation;** in this case the “EC declaration of Conformity: appendix I” may not be used. As a consequence, the installer in turn becomes the manufacturer of the “automatic barrier”, and must therefore observe all requirements of the Machinery Directive 2006/42/EC. The manufacturer must complete a risk assessment, which also includes the list of essential safety requirements as stated in “appendix I of the Machinery Directive”, specifying the relative solutions adopted. Note that the risk assessment is one of the documents that constitutes the automation “technical documentation”. This must be compiled by a professional installer with the possibility of using the “Declaration of Conformity” in appendix II to be compiled by the installer of the road barrier.

Special warnings regarding suitability of this product in relation to the “Machinery” Directive 2006/42/CE; to be taken into consideration when the installer becomes the manufacturer of the product.

The road barrier is issued onto the market as a “quasi machine” and therefore constructed for incorporation in a machine or to be assembled with other machinery to produce a single “machine” in accordance with the Directive 2006/42/EC only in conjunction with the other components and in the ways as described in this instruction manual. As established in directive 2006/42/EC, this product may not be started up until the manufacturer of the machine, in which this product is incorporated, has not identified and declared as compliant with the directive 2006/42/EC.

• **“Low Voltage” Directive:**

Particular warnings concerning the suitable use of this product in relation to the 2006/95/EEC “Low Voltage” Directive:

This product meets the requirements of the “Low Voltage” Directive if used as specified in the configurations as envisaged in this instruction manual and in combination with the articles listed in the product catalogue of Nice S.p.a. These requirements may not be guaranteed if the product is used in configurations or with other products that have not been foreseen; the use of the product is prohibited in these situations until the correspondence to the requirements foreseen by the directive have been verified by those performing the installation.

• **“Electromagnetic compatibility” Directive:**

Particular warnings concerning the suitable use of this product in relation to the 2004/108/EEC “Electromagnetic Compatibility” 2004/10/EEC:

This product has been subjected to tests regarding the electromagnetic compatibility in the most critical of use conditions, in the configurations foreseen in this instructions manual and in combination with articles present in the Nice S.p.a. product catalogue.

The electromagnetic compatibility may not be guaranteed if the product is used in configurations or with other products that have not been foreseen; the use of the product is prohibited in these situations until the correspondence to the requirements foreseen by the directive have been verified by those performing the installation.

1.3.1 - Installation criteria and special warnings related to essential requirements

This product, if correctly installed, complies with the essential requirements as envisaged by the European Directive on “Construction Products” 89/106/EEC according to the provisions of harmonised standard EN 13241-1, as specified

in **Table 1**; and by the European Directive on “Machinery” 2006/42/EC.

Important! – If the road barrier is intended exclusively for vehicle transit, it would be excluded from the field of application of EN 13241-1; in this case, compliance with some of the requirements stated in Table 1 may not be compulsory. Transit may be considered “exclusively vehicle” when there is an express prohibition for other types (for example pedestrians), such as by using adequate signs and, if other types are required, there is adequate space in the immediate vicinity.

• **Release of hazardous substances:**

The product does not contain and/or release hazardous substances in conformity with the provisions of the standard EN 13241-1, point 4.2.9 and according to the list of substances stated in the web site of the European Community *: [http:// europa.eu.int/comm/enterprise/construction/internal/dang-sub/ dangmain_en.htm](http://europa.eu.int/comm/enterprise/construction/internal/dang-sub/dangmain_en.htm)

(*) Last update: 17/03/2003

Special warning to guarantee compliance with the requirement – It is essential that also all other materials used in installation, such as electric cables, comply with this requirement

• **Resistance to wind load:**

Table 1a specifies resistance of the pole supplied to the differential pressure of the wind. The tests were performed with the pole fitted with the impact protection profile; other accessories may increase the exposed surface and thus reduce the resistance to wind load.

• **Safe opening for vertically moving doors:**

The product does not cause uncontrolled movements or dropping of the pole in the event of a fault on a single component of the suspension or balancing (spring) system.

Special warnings to guarantee compliance with the requirements:

- Perform installation in strict observance of all instructions in chapters “**3 - Installation**” and “**5 - Testing and Commissioning**”.

- Ensure that a maintenance schedule is drawn up (for example, by using a “Maintenance indicator” connected to the FLASH output associated with the relative function - see Table 10); in which, all instructions in the chapter “Maintenance Schedule” must be strictly followed.

• **Mechanical strength and stability of the product:**

The product is designed and constructed to ensure that, during normal use, all forces applied, impact and normal wear will not damage or impair mechanical performance.

Caution: See specifications for the requirement “Safe opening for vertically moving doors”.

• **Manoeuvring forces for power-operated doors/gates:**

The operating forces applied by the pole in relation to the risks of crushing and impact are protected by means of one of the three following methods:

1 For operation with “hold-to-run” controls: as specified in EN 12453: 2000, point 5.1.1.4. In this case the control button must be located in sight of the automation, and if accessible by the public, the control must not be available to the latter, for example protected by means of a key-operated selector switch.

2 For “semi-automatic” operating mode: by force limitation as specified in EN 12453:2000, points 5.1.1.5 and 5.1.3.3.

3 For “automatic” operating mode: by force limitation as specified in EN

TABLE 1 - Essential requirements for CE marking (according to prospect ZA.1 of standard EN 13241-1)

Essential requirements	Point of standard	Result
Resistance to water	4.4.2	NPD*
Release of hazardous substances	4.2.9	Compliant
Resistance to wind load	4.4.3	Compliant
Heat resistance	4.4.5	NPD*
Permeability to air	4.4.6	NPD*
Safe opening for vertically moving doors	4.2.8	Compliant
Definition of the geometry of glass components	4.2.5	NPD*
Mechanical strength and stability	4.2.3	Compliant
Manoeuvring forces for power-operated doors/gates	4.3.3	Compliant
Durability of resistance to water, heat resistance and permeability to air	4.4.7	NPD*

* NPD = No Performance declared, when the product does not offer this performance, for example “Permeability to air”, or when the requirement is not applicable, such as “Definition of the geometry of glass components”.

TABLE 1a

Class	Barrier			
	M3BAR	M5BAR	M7BAR	LBAR
Wind load [Pa]	4	4	2	2*
Maximum wind speed [Km/h]	≤ 1000	≤ 1000	≤ 450	≤ 450
Descriptive term	Hurricane	Hurricane	Violent storm Squall	Violent storm Squall

* Class 2 is achieved using accessory model WA11

12453:2000, points 5.1.1.5 and 5.1.3; in this case installation is compulsory of at least one pair of photocells as shown in **fig. 1**.

Specific warnings for “semi-automatic” and “automatic” operating modes: the type tests to check the efficiency of force limitation were performed with the Force setting at the factory level and Speed setting at the factory value; with the pole assembled as per the instructions and fitted with the “impact protection profile” above and below the pole and with the accessory “indicator lights” XBA4 inserted on the upper impact protection profile.

Special warning to guarantee compliance with the requirement: See specifications for the requirement “Safe opening for vertically moving doors”.

3 INSTALLATION

3.1 - Preliminary checks for installation

Before proceeding with installation, check the condition of the product components, suitability of the selected model and conditions of the intended installation environment.

- Ensure that all material used is in perfect condition and suitable for use.
- Ensure that all product application limits can be observed (see paragraph 3.2).
- Ensure that the selected installation environment is compatible with the overall dimensions of the product (**fig. 2**).
- Ensure that the selected surfaces for barrier installation are solid and guarantee a stable fixture.
- Make sure that the fixing zone is not subject to flooding. If necessary, mount the barrier raised from the ground.
- Ensure that the space around the barrier enables easy and safe completion of manual manoeuvres.
- Ensure that there are no obstacles along the pole trajectory which prevent the opening and closing manoeuvres.
- Ensure that each device to be installed is in a sheltered location and protected against the risk of accidental impact.

3.2 - Product application limit

Before installing the product, ensure that all values specified in the chapter “Technical product specifications” are compatible with the intended use.

- Ensure that the estimated durability (see paragraph 3.2.1) is compatible with the intended use.
- Ensure that all limits, conditions and warnings in this manual can be observed.

3.2.1 - Product durability

The lifetime is the average economic duration of the product. The value of lifetime is strongly influenced by the intensity of the manoeuvres, i.e. the sum of all factors that contribute to product wear (see **Table 2**).

To estimate the lifetime of your automation, proceed as follows:

01. Add the values of the items in **Table 2** regarding the system conditions;
02. In **Graph 1** from the value obtained above, trace vertical line until it intersects the curve; from this point trace a horizontal line until it intersects the line of the “manoeuvre cycles”. The obtained value is the estimated lifetime of your product.

The lifetime values specified in the graph are only obtainable if the maintenance schedule is strictly observed (see chapter “Maintenance schedule”). The estimation of lifetime is made on the basis of design calculations and the results of tests performed on prototypes. As it is only an estimation, it does not represent any form of guarantee on the effective lifetime of the product.

Example of calculating the durability of the road barrier (refer to **Table 2 and **Graph 1**):** M5BAR with mobile support (severity index of 10%) - Speed level 3 (severity index of 10%) - Braking (severity index of 10%):

Total severity index = 30%

The estimated durability is approx. 550,000 manoeuvre cycles.

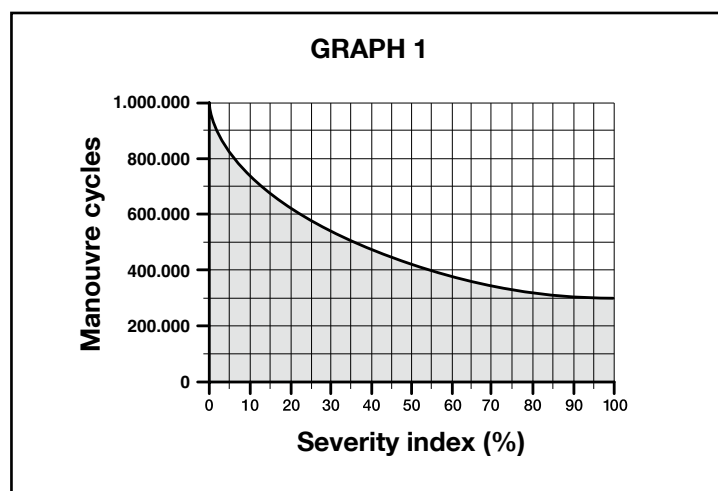

2 PRODUCT DESCRIPTION AND INTENDED USE

MBAR and LBAR are electromechanical road barriers for residential and industrial use; they control the opening and closing of a road transit point with widths from 3 to 8 metres.

Cabinet	Pole	Installable accessories			
		Rubber	Lights	Rack	Mobile support
M3BAR	3 m	✓	✓		
M5BAR	4 m	✓	✓	✓ (1 piece)	✓
	5 m	✓	✓		
M7BAR	5 m	✓	✓	✓ (2 pieces)	✓
	3+3 m	✓	✓	✓ (2 pieces)	✓
	3+4 m	✓	✓		
LBAR	3+4 m	✓	✓	✓ (3 pieces)	✓
	4+4 m	✓	✓	✓ (3 pieces)	✓
	4+5 m	✓	✓		

IMPORTANT! – All uses other than the intended use described and use in environmental conditions other than those described in this manual should be considered improper and forbidden!

These barriers are fitted with an electromechanical gearmotor with a 24 V motor, with incorporated Loop Detector for 2 magnetic loops, with electric limit switch system and a flashing light signal which can be incorporated in the lid (optional accessory). These two models may be installed as counterposed barriers in “Master-Slave” mode to cover a surface of a road transit point exceeding 8 metres (see paragraph 7.5).

The control unit is set up for connection to devices belonging to the Nice Opera system and to the “Solemyo” solar power system (see paragraph 4.10.3).

The barriers run on electric energy and in the event of a power failure the pole can be released and moved manually. Alternatively the buffer battery model PS224 can be used (optional accessory - see paragraph 4.10.2), which guarantees a number of automation manoeuvres in the first few hours of power failure. Should you desire to prolong this period or extend the number of manoeuvres, the Stand by function should be enabled (see table 6).

Important points on consulting the manual

- In this manual, the words “road barrier” refer to the two products “MBAR” and “LBAR”.
- The accessories mentioned in the manual are optional.

Available accessory list:

- XBA4 - M3BAR and M5BAR pole lights
- XBA5 - Aluminium pole painted white, L. 5150 mm
- XBA6 - M7BAR pole lights
- XBA7 - LED flashing lights that can be installed inside the lid
- XBA8 - LED traffic lights that can be installed inside the lid
- XBA9 - Universal joint
- XBA10 - pivottante connection
- XBA11 - Pivot for pole
- WA11 - Adjustable pole support (compulsory for LBAR)
- WA12 - Mobile support
- XBA13 - Impact protection rubber kit
- XBA14 - Aluminium pole painted white, L. 4150 mm
- XBA15 - Aluminium pole painted white, L. 3150 mm
- XBA16 - MBAR foundation plate
- XBA17 - LBAR foundation plate
- XBA18 - LBAR pole lights

	Severity Index			
	M3BAR	M5BAR	M7BAR	LBAR
Pivot Pole (XBA12)	20	15	—	—
Speed level 3	15	10	15	15
Speed level 2	0	0	10	10
Interruption of manoeuvre via Foto > 10%	15	10	15	15
Interruption of manoeuvre via Alt > 10%	10	10	15	15
Mobile support (XBA11)	—	10	10	10
Braking	10	10	10	10
Force equal to 7 or 8	10	10	10	10
Force equal to 5 or 6	5	5	5	5
Presence of saline mist	10	10	10	10
Presence of dust or sand	5	5	5	5
Rack	—	5	5	5
Room temperature higher than 40° and lower than 0° C	5	5	5	5

TABLE 3 - Technical specifications of electrical cables (Fig. 1)

Connection	Cable type	Maximum admissible length
A: mains power supply cable	3 x 1,5 mm ²	30 m (note 1)
B: BlueBus cable	2 x 0,5 mm ²	20 m (note 2)
C: key-operated selector switch cable	2 cables 2 x 0,25 mm ² (note 3)	30 m
Input cable Open	2 x 0,25 mm ²	30 m
Input cable Close	2 x 0,25 mm ²	30 m
Flashing light cable (note 4) with aerial	2 x 0,5 mm ² RG58 shielded type	30 m 15 m (less than 5 m recommended)
Pole indicator cable Open (note 4)	2 x 0,5 mm ²	30 m
Pole lights (note 4)	—	—
Loop Detector Cable	1 x 1,5 mm ² twisted (note 5)	20 m twisted (note 5)
Master/Slave Cable	3 x 0,5 mm ²	20 m

IMPORTANT! – The cables used must be suited to the installation environment.

Note 1 – If the power cable is longer than 30 m, a cable with a larger cross-section is required (3x2.5 mm²) and safety earthing is necessary in the vicinity of the automation.

Note 2 – If the BlueBus cable is longer than 20 m, up to a maximum of 40 m, a cable with a larger cross-section is required (2x1 mm²).

Note 3 – These 2 cables may be replaced by a single cable 4x0.5 mm².

Note 4 – Before making the connection, check that the output is programmed for the device to be connected (see paragraph 6.2 - Table 8).

Note 5 – Shorten the two ends coming out of the loop, with at least 20 turns per metre.

3.3 - Preliminary work prior to installation

3.3.1 - Identify the scheme on the basis of which to position each plant component

With reference to the standard layout shown in **fig. 1**, locate the approximate position of each component in the system. The diagram shows all components in the product package (**fig. 3**): [a] road barrier with built-in control unit; [b] pole cover and support; [c] no. 2 photocell boxes; [d] no. 4 half-shells for pole connection; [e] fixed pole cap; no. 2 connections for protection rubber; no. 2 connections without protection rubber; [f] keys for manually locking and unlocking the pole; keys for locking the cover; minor metal parts (screws, washers, etc.); [g] foundation plate; [h] no. 4 fixing bolts.

3.3.2 - Determine the path of the connecting cables

CAUTION! – Position the ends of the ducting used for electrical cables in the vicinity of the points at which various components will be connected. **Note:** The ducting serves to protect electric cables and prevent accidental damage, such as in the case of impact. Prepare the electrical cables needed for your system, referring to **fig. 1** and “Table 3 - Technical characteristics of electrical cables”.

3.3.3 - a) - Position the balancing spring in relation to pole weight, complete with the required accessories. b) - Set the direction for closing the pole: to the right or to the left of the motor.

The barrier leaves the factory with the following settings:
– balancing spring anchored in **holes which are not final**.
– pole closing manoeuvre **to the left**.

These settings are arbitrary; you must therefore perform the following checks to determine whether they should be changed or not (that is, whether or not you need to move the spring connection on the balancing lever and on the plate at the foot of the barrier to another hole).

- If you plan to install only one accessory, identify in box “A” of Table 4 your barrier model, the planned pole length and, finally, the accessory you intend to assemble on the pole; then read the corresponding letter and number of the holes in which to hook the spring;
- If you plan to install multiple accessories, identify in box “B” of Table 4 your barrier model, pole length and, finally, the type and number of accessories you wish to assemble on the pole; then add up the numbers between brackets for the applicable accessories. Finally, use the result of the sum to read the letter and number identifying the holes to which to hook the spring in the lower part of box “B”.
- If you must close the pole to the right of the motor, it will be necessary to move the spring connection to one of the holes on the other arm of the balancing lever.

Proceed as follows to hook the spring in a different hole from the factory settings:

01. Remove the upper barrier cover (**fig. 4**).
02. Loosen the 2 screws fixing the cabinet door (**fig. 5**).
03. – (M3BAR - M5BAR - M7BAR) Turn the nut shown in **fig. 6** (step a) anti-clockwise and then manually turn the spring clockwise to slacken its tension (**fig. 6** - step b).
– (LBAR) Turn the nut shown in **fig. 7** (step a) clockwise to slacken the tension of the balancing spring.
04. Slacken the bolt anchoring the spring to the balancing lever (M3BAR - M5BAR - M7BAR: **fig. 6** - step c; LBAR: **fig. 7** - step b).
05. – (M3BAR - M5BAR) Slacken the bolt anchoring the spring to the perforated plate positioned at the foot of the barrier (**fig. 6** - step d).
– (M3BAR - M5BAR) Slacken the bolt anchoring the spring to the perforated plate positioned at the foot of the barrier (**fig. 7** - step c).
06. If you wish to set the pole to close on the right of the barrier, slacken the gearmotor (**fig. 8** - also refer to point 3.6) and turn the balancing lever 90° (**fig. 9**).
07. Use Table 4 to identify the new holes to which to hook up the two ends of the spring.
08. – (M3BAR - M5BAR) Hook the spring plate to the perforated plate at the foot of the barrier (**fig. 10** - step a) then anchor the eye of the spring to the balancing lever, tightening the bolt all the way (**fig. 10** - step b)
– (M7BAR - LBAR) Anchor the upper eye of the spring to the balancing lever, tightening the bolt all the way (**fig. 11** - step a); anchor the lower eye of the spring to the perforated plate at the foot of the barrier, tightening the bolt all the way (**fig. 11** - step b).
09. If you slackened the gearmotor at point 06, tighten it again (**fig. 12**), referring to point 3.6.

3.4 - Barrier lift fixture

3.4.1 - If the support surface already exists

01. Open the cabinet of the barrier (**fig. 13**);
02. Place the barrier on the fixing surface and trace the points where the slots are to be fixed (**fig. 14**);
03. Move the barrier and drill the traced surface points; then insert 4 expansion bolts, not supplied (**fig. 15**);
04. Position the barrier correctly and secure by means of the relative nuts and washers not supplied (**fig. 16**).

3.4.2 - If the support surface does not exist

01. Dig the foundation pit (*) to house the foundation plate;

TABLE 4

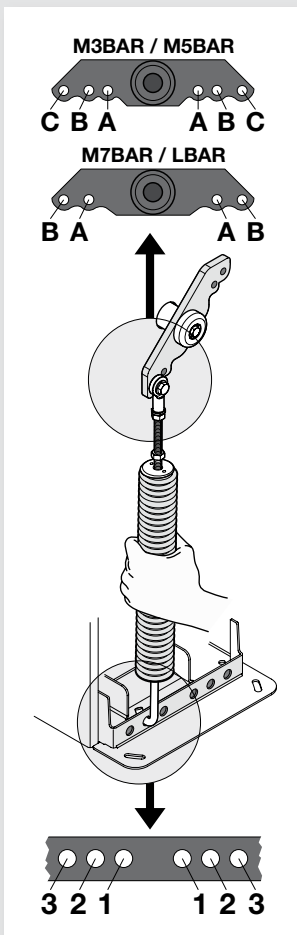

A	M3BAR		M5BAR			M7BAR	LBAR
	2,65 m XBA15 (3,15 m) - 0,50 m	3,15 m XBA15 (3,15 m)	3,50 m XBA14 (4,15 m) - 0,65 m	4,15 m XBA14 (4,15 m)	5,15 m XBA5 (5,15 m)	7,33 m XBA15 + XBA14	9,33 m XBA14 + XBA5
XBA13	A 1	A 3			C 2	B 2	B 1
XBA13	A 1	A 3			C 2	B 2	B 1
XBA11	B 3	B 3	C 1	C 3			
B	M5BAR		M7BAR		LBAR		
	3,50 m XBA14 (4,15 m) - 0,65 m	4,15 m XBA14 (4,15 m)	5,15 m XBA5 (5,15 m)	5,00 m XBA15+XBA15 (6,30 m) - 1,30 m	6,33 m XBA15 + XBA15	7,33 m XBA15 + XBA14	8,33 m XBA14 + XBA14
XBA13	(0)*	(0)	(0)	(0)	(0)	(0)	(0)
XBA13	(1)	(1)	(1)	(1)	(1)	(1)	(1)
WA13	(1)	(1)	(2)	(1)	(1)	(2)	(2)
WA12	(5)	(4)	(4)	(3)	(3)	(3)	(3)
	0 ÷ 1 = B 2	0 ÷ 1 = B 3	0 ÷ 2 = A 2	0 ÷ 2 = B 1	0 ÷ 2 = B 1	0 ÷ 2 = A 1	0 ÷ 2 = A 3
	2 ÷ 7 = B 3	2 ÷ 4 = C 1	3 ÷ 5 = A 2	3 ÷ 5 = B 2	3 ÷ 5 = B 2	3 ÷ 4 = A 2	3 ÷ 6 = B 1
		5 ÷ 6 = C 2	6 ÷ 7 = A 3			5 ÷ 6 = A 3	

(*) - identify in box "B" in Table 4 your barrier model, pole length and, finally, the type and number of accessories you wish to assemble on the pole; then add up the numbers between brackets for the applicable accessories. Finally, use the result of the sum to read the letter and number identifying the holes to which to hook the spring in the lower part of box "B".

Example: M5BAR with 4.15m pole + Rack WA13 (1 pz.) (value: 1) + Pole lights (value: 1) = Sum of values: 2; result = **POSITION C - 1**

02. Prepare ducting for connection cables (fig. 17);
03. On the foundation plate, fix the 4 bolts, placing a nut on the upper side of each and one on the lower side of the plate (fig. 17). **Caution** - The lower nut must be tightened down to the threaded section;
04. Now cast the concrete, and before it sets, embed the foundation plate, which must be positioned flush with the surface, parallel to the pole and perfectly level (fig. 17). Wait for the concrete to set completely; in general, at least 2 weeks;
05. Remove the 4 upper nuts of the bolts;
06. Open the cabinet of the barrier (fig. 18);
07. Position the barrier correctly and secure it by means of the relative nuts and washers supplied with the foundation plate and removed in point 04 (fig. 19).

(*) Note - The fixing surface must be perfectly smooth and flat. If the surface is in concrete, it must be at least 0.15 m thick, and must be adequately reinforced with steel cages. The concrete volume must be greater than 0.2 m³ (a thickness of 0.25 m corresponds to 0.8 m²; in other words equal to a square base of approx. 0.9 m per side). Anchoring to the concrete can be by means of 4 expansion bolts, fitted with 12 MA screws, which resist to a traction load of at least 400 Kg. If the fixing surface is in another material, the consistency must be checked and ensure that the 4 anchoring points can resist a load of at least 1000 Kg. For fixture, use 12 MA screws.

3.5 - Installing the rod and the accessories provided

3.5.1 - Pole support assembly

01. Insert the two plugs in the relative seats on the output motor shaft (fig. 20);
02. Position the support on the output motor shaft, placing it in the "vertical pole" position and tighten the relative screws and washers fully down to secure (fig. 21);

03. Position the pole cover and partially secure by means of the 6 screws supplied (fig. 22).

3.5.2 - Assembling a pole formed of a single piece, whole or cut.

Possible lengths:

- M3BAR:** 2,65 m = XBA15 (3,15 m - 0,50 m = 2,65 m)
3,15 m = XBA15 (3,15 m)
- M5BAR:** 3,50 m = XBA14 (4,15 m - 0,65 m = 3,50 m)
4,15 m = XBA14 (4,15 m)
5,15 m = XBA5 (5,15 m)
- M7BAR:** 5,15 m = XBA5 (5,15 m)

01. Assemble the two pole insertions (fig. 23);
02. Insert, from the same end of the pole, the insertions just assembled. Use a rubber mallet (fig. 24);
03. Lightly grease the aluminium guide on both sides (fig. 25);
04. Perform this operation on both ends of the pole: insert the first part of impact protection rubber in the slot, through to the end of the pole; then insert the joint for the impact protection rubber (fig. 26) and repeat with all parts;
05. The impact protection rubber may protrude by about 1 cm from the end of the profile (fig. 27):
A) position the pole plug and lock it with the two screws (fig. 28);
B) position and block the two rubber cover plugs (fig. 28);
06. Insert the pole assembly in the pole support shell, pushing it up to the end and then tighten the 6 previously inserted support screws fully down (fig. 29).

3.5.3 - Assembling a pole formed of two pieces, either whole or cut.

Possible lengths:

- M7BAR:** 5,00 m = XBA15 (3,15 m - 1,30m = 1,85*) + XBA15 (3,15 m)
6,33 m = XBA15 (3,15 m) + XBA15 (3,15 m)
7,33m = XBA15 (3,15 m*) + XBA14 (4,15 m)
LBAR: 7,33 m = XBA15 (3,15 m*) + XBA14 (4,15 m)
8,33 m = XBA14 (4,15 m) + XBA14 (4,15 m)
9,33 m = XBA14 (4,15 m*) + XBA5 (5,15 m)

(*) - CAUTION! – In rods made up of two pieces, it is obligatory to anchor the shorter piece to the aluminium support. Point 02 of the procedure must therefore be changed as follows:

01. Assemble the two plastic pole insertions (fig. 23).
02. Insert the assembled connection on one end of the shorter pole using a rubber mallet (fig. 24).
03. Insert the universal joint in the free ends of the two poles. Take care in correctly directing the joint since the heads of the screws must be on the same part of the holes on the poles (fig. 30);
04. Act to the same degree on the three screws of the joint by loosening them in a way to “expand” the joint inside the poles (fig. 31);
05. Lightly grease the aluminium guide on both sides (fig. 25);
06. Perform this operation on both ends of the pole: insert the first part of impact protection rubber in the slot, through to the end of the pole; then insert the joint for the impact protection rubber (fig. 26) and repeat with all parts;
07. The impact protection rubber may protrude by about 1 cm from the end of the profile (fig. 27):
A) position the pole plug and lock it with the two screws (fig. 28);
B) position and block the two rubber cover plugs (fig. 28);
08. Insert the pole assembly in the pole support shell, pushing it up to the end and then tighten the 6 previously inserted support screws fully down (fig. 29).

3.5.4 - Installation of required pole accessories

After installing the pole and the protection rubber, before proceeding any further it is important to install any other accessories that may be required on the pole. For instructions on installation of these accessories, refer to their instruction manuals.

3.6 - Manually releasing and locking the barrier

This operation is required in the event of a power failure or malfunction. To manually release or lock the barrier, insert the key provided and turn it 180° to the right or to the left (fig. 32).

IMPORTANT! • The release and locking operations must be performed only when the pole is horizontal and stationary. • It is possible to carry out the manual release and lock on both sides of the barrier by moving the locking cylinder (see paragraph 3.6.1).

3.6.1 - How to move the locking cylinder for manual release and lock

01. Insert the key supplied and turn through 180° clockwise (fig. 33-a);
02. From inside the caisson, pull the U-shaped clip holding the lock cylinder in place (fig. 33-b) and pull off the cylinder on the outside of the caisson (fig. 33-c);
03. From the other side of the caisson, remove the plastic cap (fig. 34-a) and insert the lock cylinder into the hole provided (fig. 34-b);
04. Finally, from inside the caisson, insert the U-shaped clip for holding the locking cylinder in place from below (fig. 34-c).

3.7 - Limit switch mechanical stop adjustment

01. Manually release the gearmotor: see paragraph 3.6;
02. Manually move the pole through a complete Opening and Closing manoeuvre;
03. Then use the screws on the mechanical limit switch stops (fig. 35 and 36) to adjust the horizontal pole setting, when it is closed, and the vertical pole setting, when it is open.
04. Tighten the nuts well.

3.8 - Pole balancing

Balancing the pole serves to find the best balance between the total pole **weight** complete with the accessories installed and the **force** opposed to it by the tension of the balancing spring. Proceed as follows to check whether spring tension is appropriate to balance the weight of the pole and its accessories, if any.

3.8.1 - M3BAR / M5BAR / M7BAR Pole balancing

01. Manually release the gearmotor: see paragraph 3.6;
02. Manually move the pole to mid-travel (45°) and leave stationary. If the pole tends to lift, reduce the tension of the spring by manually turning it clockwise (fig. 37-a). If, on the contrary, the pole tends to drop, increase spring tension by manually turning it clockwise (fig. 37-b). Note - the off-balance value is only acceptable when the force required to move the pole* when open, closed and in all the other positions, is lower than or equal to half of the nominal value (equal to about 1.5 kg for M3; 3.5 kg for M5 and 4.5 kg for M7, about 5 kg at 1 m). [*] force measured at right angles to the pole and at 1 m from the rotation axis].
03. Repeat point 02 positioning the pole also at approx. 20° and approx. 70°.

If the pole remains still in position, this means that balancing is correct; a slight off balance is admissible, **but the pole must never move significantly.**

04. Lock the balancing spring in place with the nut (fig. 37-c);
05. Manually lock the gearmotor: see paragraph 3.6.

3.8.2 - LBAR Pole balancing

01. Manually release the gearmotor: see paragraph 3.6;
02. Manually move the pole to mid-travel (45°) and leave stationary. If the pole tends to lift, reduce the tension of the spring by manually turning the nut clockwise (fig. 38-a). If, on the contrary, the pole tends to drop, increase spring tension by turning the nut anti-clockwise (fig. 38-b). Note - the off-balance value is only acceptable when the force required to move the pole* when open, closed and in all the other positions, is lower than or equal to half of the value of the nominal torque (for this product, about 6.5 kg at 1 m). [*] force measured at right angles to the pole and at 1 m from the rotation axis].
03. Manually lock the gearmotor: see paragraph 3.6.

4 ELECTRICAL CONNECTIONS

CAUTION! – All electrical connections must be made with the unit disconnected from the mains power supply.

01. Remove the cover by loosening the screws and turning the key clockwise (fig. 39);
02. Route the electric cables inside the barrier, starting from the base towards the control unit and routing them to the left. Instead, the cables of the Loop detectors and for the “Master-Slave” mode must be made by routing them to the right;
03. Route the power supply cable through the cable gland and connect them to the 3-contact terminal with fuse. Tighten the cable gland by tightening the screws (fig. 40);
04. Connect the other cables as shown in the wiring diagram in fig. 41. Note – To facilitate cable connections, the terminals can be removed from their seats.

4.1 - Description of the electrical connections

• **LIGHT** = this output is programmable (see Chapter 6, paragraph 6.2 - Level 2 programming - adjustable parameters) to connect one of the following devices:

– **Flashing light:** if programmed as “flashing light” on the “LIGHT” output, a NICE flashing light model “LUCY B, MLB or MLBT” with a 12 V 21 W car type lamp can be connected. During the manoeuvre it flashes at intervals of 0.5 s lit and 0.5 s off. Factory setting: configuration for operation as “Flashing light for pole lights” 24 V/10 W.

– **“pole open indicator” - “activated if the pole is closed” - “activated if pole is open” - “flashing light for pole lights” and “maintenance indicator”:** if programmed with one of these 5 functions on the “LIGHT” output, a 24 V indicator (max. 10 W) can be connected for the following signals:

“Pole open indicator” function

- Pole closed: Off
Pole opening: slow flashing light
Pole closing: quick flash light
Pole open (not closed): on

“Active if pole closed” function

- Pole closed: on
All other cases: Off

“Active if pole open” function

- Pole open: on
All other cases: Off

Function “flashing light for pole lights”

The indicator light or pole lights indicate execution of the manoeuvre in progress by flashing constantly at regular intervals (0.5 sec on; 0.5 seconds off)

Function “Maintenance indicator”

- indicator lit on for 2 seconds at the start of the opening manoeuvre = number of manoeuvres less than 80%
- flashing light indicator during execution of the entire manoeuvre = number of manoeuvres between 80 and 100%
- indicator constantly flashing = number of manoeuvres greater than 100%.

– **Suction cup:** a 24V max 10W suction cup can be connected (versions with electromagnet only, without electronic devices). When the pole is closed, the suction cup is activated to lock the pole in place. During the opening and closing manoeuvre it is deactivated.

– **Electric block:** a 24 V max 10 W electric block with latch can be connected (versions with electromagnet only, without electronic devices). During the opening manoeuvre, the electric lock is activated and remains active to free the pole and perform the manoeuvre. In the closing manoeuvre ensure that the electric block re-engages mechanically.

– **Electric lock:** a 24 V max 10 W electric lock with latch can be connected (versions with electromagnet only, without electronic devices). At the start of the opening manoeuvre, the electric lock is activated for a short period to release the pole and complete the manoeuvre. In the closing manoeuvre ensure that the electric lock re-engages mechanically.

• **FLASH** = this output is programmable by using the Oview programmer. It is possible to connect the same devices of the LIGHT output. In the factory it is configured for operation with flashing light 12 V 21 W.

• **SCA** = this output is programmable by using the Oview programmer. It is possible to connect the same devices of the LIGHT output. In the factory it is configured for operation with Pole Open Indicator 24 V 10 W.

• **BLUEBUS** = this terminal enables the connection of compatible devices; all are connected in parallel with just two wires conveying the electric power and communication signals. For further details see Chapter 8.

• **STOP** = input for devices that block or shut down the manoeuvre in progress; by setting the input accordingly, it is possible to connect Normally Closed type contacts, Normally Open contacts, constant resistance or optical devices. For further details see chapter 8.

• **PP** = input for devices control movement in Step-Step mode, enabling the connection of Normally Open contacts.

• **OPEN** = input for devices which control only opening manoeuvre. NO contacts can be connected to this input.

• **CLOSE** = input for devices which control only closing manoeuvre. NO contacts can be connected to this input.

• **AERIAL** = input for connection of the aerial for the radio receiver (the aerial is incorporated on LUCY B, MBL, MLBT).

• **LED BOARD OUTPUT** = this output is programmable (see Chapter 6, paragraph 6.2 - Level 2 programming - adjustable parameters) and is used to connect the LED flashing light board (XBA7) or the LED traffic lights board (XBA8). With the factory setting, it performs the flashing light function, flashing at intervals of 0.5 s lit and 0.5 s off. In addition, diagnostic flashing is performed.

• **LOOP1** = Loop Detector input to connect a loop detector, for the detection of metal masses. The operating modes associated to this input may be modified with the Oview programmer (see paragraph 7.5 – Loop Detector). Factory setting: configuration for the opening manoeuvre

• **LOOP2** = Loop Detector input to connect a loop detector, for the detection of metal masses. The operating modes associated to this input may be modified with the Oview programmer (see paragraph 7.5 – Loop Detector). Factory setting: configuration for the opening manoeuvre.

• **MASTER-SLAVE** = connector for the connection of 2 barriers in Master-Slave mode (see paragraph 7.6 – Master-Slave).

IMPORTANT! – NEVER CONNECT DEVICES OTHER THAN THOSE SPECIFIED.

4.2 - Initial start-up and electrical connections

CAUTION! – The final connection of the automation to the electrical mains must be made exclusively by a qualified skilled technician, in observance of current local standards.

Connect the control unit to an electric power line equipped with an earthing system. Envisage a mains disconnect device, with a contact opening distance that ensures complete disconnection in the conditions of overvoltage category III, or envisage a plug and socket system.

After powering up the control unit, perform the following checks:

- Make sure that the “Bluebus” LED flashes quickly for a few seconds and then regularly with a frequency of about one flash per second.
- If photocells are present, check that the leds on the latter also flash (both on TX and RX elements); the type of flash is not significant as this depends on other factors.

- Check that the device connected to the FLASH output or XBA7 LED flashing light is off (with factory setting).

If the above conditions are not satisfied, switch off the power supply to the control unit and check the electrical connections previously made.

For more useful information see also chapter “8 Troubleshooting” (troubleshooting guide).

4.3 - Pre-set functions

The control unit is equipped with a series of programmable functions, which are factory set with the most commonly used values. These values can be modified at any time: See chapter 6.

4.4 - Recognition of the connected devices

After the initial power-up, the control unit must be able to recognise the devices connected on the inputs “Bluebus” and “Stop”.

CAUTION! – The learning phase must be performed even if no device is connected to the control unit.

To indicate whether this operation is necessary, leds “L1” and “L2” on the control unit emit a number of flashes.

01. Press and hold down “Open” and “Set” keys at the same time;

02. Release the keys when LEDs L1 and L2 start flashing quickly (after approx. 3 seconds).

03. Wait a few seconds for the control unit to complete the device learning phase. At the end of this phase, the “Stop” led must be lit and leds “L1” and “L2” must turn off (leds “L3” and “L4” may start flashing to indicate that the positions have not been learnt).

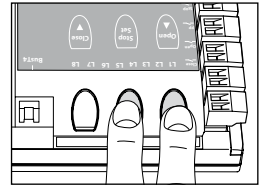

This procedure must be repeated in the case of modifications to the devices connected to the terminals BlueBus and Stop; for example, after connecting a new device to the control unit.

4.5 - Recognition of limit positions on opening and closing

After learning the connected devices, the control unit also has to learn the positions of the mechanical stops. In this phase, the pole travel distance is read, measured from the closing mechanical stop to the opening mechanical stop.

01. Manually release the gearmotor (see chapter 3.6) and manually position the pole at approx. 45° (mid-travel);

02. Lock the gear motor (see paragraph 3.6);

03. Press and hold down “Close” and “Set” keys at the same time;

04. Release the keys when the manoeuvre starts (after approx. 3 seconds);

05. Wait a few seconds for the control unit to complete the position learning phase: close, open and close of the pole, with intervals with a 3 second pause.

Warnings! • Do not interrupt the three manoeuvres: if they are interrupted, it will be necessary to repeat the entire procedure from point 01. • While performing the three manoeuvres, make sure that the pole balancing lever hits the mechanical stops on the limit switches. If this does not happen, stop the procedure, adjust the mechanical stops on the limit switch and repeat the procedure from point 01. • If leds “L3” and “L4” flash after completion of the three manoeuvres, an error has occurred. In this case, repeat the entire procedure starting from step 01.

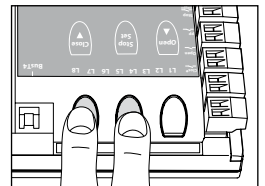

IMPORTANT! – The parameters concerning the deceleration positions and the braking intensity, are functions preset by the unit. In any case it is possible to modify them by directly acting on the unit, modifying the parameters “L5 Long/short deceleration” (see Table 6 - paragraph 6.1)” and “L8 Braking” (see Table 6 - paragraph 6.2)” or by using the Oview programmer.

4.6 - Pole movement check

After learning about the devices, a number of Opening and Closing manoeuvres should be performed to ensure correct pole movement.

01. Press “Open” to activate an Opening manoeuvre; ensure that the pole starts to decelerate before reaching the opening position;

02. Press “Close” to activate a Closing manoeuvre; ensure that the pole starts to decelerate before reaching the closing position;

03. Make sure that the LED flashing light, if present, flashes at regular intervals (0.5 sec on, 0.5 sec off) during a manoeuvre;

04. Run a number of Opening and Closing manoeuvres to ensure that there are no points of increased friction or malfunctions.

CAUTION – If the manoeuvre starts from a position different from that of one of the mechanical stops (opening or closing), it is performed at low speed.

4.7 - Connecting a radio receiver

The control unit is fitted with a SM type connector for connection of a radio receiver (optional accessory) model SMXI, SMXIS, OXI or OXIT and similar.

To insert the radio receiver, disconnect the control unit from the power mains and insert the receiver as shown in **fig. 42**.

Table 5 shows the actions performed by the control unit according to the outputs activated or the commands sent from the radio receiver.

TABLE 5	
SMXI, SMXIS, OIX, OXIT receiver in mode I or II	
output	description
Output no. 1	Step by step
Output no. 2	Partial Open (opens to approx. 45%; value programmable with Oview, see paragraph 4.10.1)
Output no. 3	Open
Output no. 4	Close
OXI receiver, OXIT programmed in "Extended Mode II"	
Command	description
Command no. 1	Step by step
Command no. 2	Partial Open (opens to approx. 45%; value programmable with Oview, see paragraph 4.10.1)
Command no. 3	Open
Command no. 4	Close
Command no. 5	Stop
Command no. 6	Apartment block Step by Step
Command no. 7	Step-Step High priority (controls also if automation is blocked)
Command no. 8	Unblock + Open
Command no. 9	Unblock + Close
Command no. 10	Open and block automation
Command no. 11	Close and block automation
Command no. 12	Block automation
Command no. 13	Release automation
Command no. 14	Master door Step by Step
Command no. 15	Slave door Step by Step

4.8 - Connecting the pole lights (optional accessory)

01. Move the pole to the vertical position;
02. Unscrew the 6 screws that hold the pole cover (**fig. 43**);
03. Remove the pole temporarily;
04. Insert the grommet in the pre-drilled hole for cable routing (**fig. 44**);
05. Route the lights cable through the impact protection rubber profile, using a guide to facilitate attachment if necessary (**fig. 45**);
06. If necessary, shorten the length of the lights cable: cuts may only be made at the points bearing the relative mark. After cutting, the plug at the cut end must be moved to seal off the new end;
07. Insert the cable first through the hole on the pole support and then through the hole on the cabinet (**fig. 46**); **Caution** – Leave a little extra cable in the pole support, to enable pole rotation through 90° without tensioning the cable;
08. Connect the lights cable to the LIGHT terminal on the control unit: see diagram in **fig. 47**. **Note** – The LIGHT output features polarity: if the lights do not illuminate, as planned, it is necessary to invert the cables connected to the terminal.
09. Position and secure the connector in the slot on the pole (**fig. 48**);
10. Insert the pole and secure with its cover, tightening the 6 screws (**fig. 49**) fully down and taking care not to pinch the wiring cable.

4.9 - Connecting the LED flashing light mod. XBA7 or traffic light to LED mod. XBA8 (optional accessories)

On the cover of the barrier a LED flashing light mod. XBA7 or red and green LED traffic light mod. XBA8 may be fitted. The operating modes of these flashing lights may be modified through the Oview programmer or with suitable programmes of the control unit. For further information, refer to the instruction manual for the two products.

4.10 - Connection of other devices

The built-in unit enables the power supply to the external devices (a radio receiver or the key-operated selector switch lighting) by receiving power from the control unit: for the type of electrical connection, refer to the figure at the side. The power supply voltage is 24 Vdc, -30%/+50%, with maximum available current 100 mA.

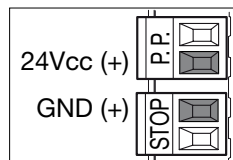

4.10.1 - Programming unit Oview

The use of the programming unit Oview enables complete and rapid management of installation, maintenance and troubleshooting of any malfunctions of the whole automation system. Oview can be connected to the road barrier by means of the BusT4 connector on the control unit.

To access the BusT4 connector, open the cover of the road barrier and insert the connector in its seat (**fig. 50**).

In general, Oview can be positioned at a maximum distance of 100 m of cable from the control unit; it can be connected to multiple control units simultaneously (max. 16) and can also remain connected during normal operation of the automation; to exceed these limits, observe the warnings in the Oview instruction manual and the Oview System Book system manual. If a OXI type radio receiver is present in the control unit, Oview enables access to the parameters of the transmitters memorised in this receiver. For detailed information, refer to the instruction manual of the Oview programmer or the barrier function datasheet also available on the website www.niceforyou.com.

4.10.2 - Buffer battery mod. PS224 (accessory)

In the event of a mains power failure, the road barrier can also be powered by a buffer battery model PS224. To install and connect the battery, proceed as follows:

Important! – The electric connection of the battery to the control unit must only be made after completing all installation and programming phases, as the battery constitutes an emergency power supply.

01. Position the buffer battery as shown in **fig. 51-a**;
02. **Disconnect the mains power** and then connect the relative cable of the buffer battery (**fig. 51**);
03. Connect the mains power.

4.10.3 - Solemyo System (photovoltaic supply)

The barrier is designed to be powered with the "Solemyo SYKCE" photovoltaic system. For connection to the control unit, use the 2 pole plug shown in **fig. 52**.

IMPORTANT!

- **When the barrier is powered by the "Solemyo" system IT MUST NOT BE POWERED by the electricity grid at the same time.**
- **Due to the limited solar power available, depending on the installation location and time of year, the barrier can perform a maximum number of manoeuvres per day. Before installing the Solemyo system, check in the relative instruction manual whether the maximum number of possible manoeuvres is compatible with the intended use.**
- **The Solemyo system can only be used efficiently if the control unit is active and set with the Standby function set to "All" mode (only possible using the Oview programmer).**

These are the most important phases of automation set-up for ensuring maximum system safety. The test can also be performed as a periodic check of automation devices. Testing and commissioning of the automation must be performed by skilled and qualified personnel, who are responsible for the tests required to verify the solutions adopted according to the risks present, and for ensuring observance of all legal provisions, standards and regulations, and in particular all requirements of the standard EN 12445, which establishes the test methods for checking automations for doors and barriers. All these operations must be performed under the direct supervision of the head installer, i.e. the person who enters his/her name and signature in box N°1 of the declaration of conformity (see appendix I).

The additional or optional devices must undergo a specific test for functionality and correct interaction with the barrier.

5.1 - Testing

The sequence of operations to be performed for testing refers to a standard system (Fig. 1) classed for "untrained users" and the automation activation set to "automatic control" which envisages, as a minimum protection level of the primary edge, device types C (force limitation - see standard EN 12445) combined with device types D (presence detectors, e.g. photocells). Bearing in mind that this type of use is among the most intensive, the same testing sequence can be effectively implemented in less intensive conditions.

- 1 Ensure that all specifications in this manual have been observed, with special reference to the chapter "1 Safety Instructions".
- 2 Check correct balancing of the pole, see paragraph 3.8.
- 3 Check correct operation of the manual release, see paragraph 3.6.
- 4 Using the transmitter or key-operated selector switch, perform tests of opening, closing and stopping the barrier, and ensure that pole movement corresponds to specifications. Test several times to check for pole movement and any defects in assembly or adjustment and any possible points of friction.
- 5 Check operation of all system safety devices one at a time (photocells, sensitive edges, etc.). Each time a device is activated the "Bluebus" LED on the control unit must flash rapidly twice to confirm acknowledgement of the event.
- 6 Check correct operation of the photocells as follows: depending on whether one or two pairs of photocells have been installed, one or two parallelepipeds in rigid material are required (e.g. wooden panels) with the measurements 70 x 30 x 20 cm. Each parallelepiped must have three sides, one for each size, in reflective material (e.g. mirror or white gloss paint) and three sides in opaque material (e.g. black matt paint). To test the photocells positioned at 50 cm from the ground, the parallelepiped must be placed on the ground or raised at 50 cm in the case of photocells placed at 1 m from the ground.
When testing one pair of photocells, the test specimen must be positioned exactly at the centre of the pole with the 20 cm sides facing the photocells and moved along the entire length of the pole (Fig. A).
When testing two pairs of photocells, the test must first be performed individually for each pair of photocells, using one test specimen, and then repeated using two test specimens.
Each test specimen must be positioned laterally with respect to the centre of the pole, at a distance of 15 cm sides and then moved along the entire length of the pole (Fig. B).

During these tests, the test specimen must be read by the photocells in any position along the entire length of the pole.

- 7 Ensure there is no interference between the photocells and other devices, by intercepting the optic axis joining the two photocells by means of a cylinder (diameter 5 cm, length 30 cm, Fig. C): pass the cylinder first close to the TX photocell, then close to the RX and lastly at the centre between the two. Ensure that in all cases the device engages, changing from the active status to alarm status and vice versa, and that the envisaged action is generated in the control unit (for example movement inversion in the Closing manoeuvre).
- 8 **Check protection against the risk of lifting:** on automations with vertical movement, it must be ensured that there is no risk of lifting. This test can be performed as follows: hang a weight of 20 kg mid-way along the pole (for example, a sack of gravel), activate an Opening manoeuvre and ensure that during operation the pole does not exceed the height of 50 cm from the closing position. If the pole exceeds this height, reduce the motor force (see chapter 6 - Table 7).
- 9 If hazardous situations generated by the moving poles are protected by means of impact force limitation, measure the force as specified in the standard EN 12445. If motor force control is used as auxiliary function with the system for reduction of impact force, test and identify the setting that obtains the best results.
- 10 **Check efficiency of the release system:** place the pole in the Closing position and manually release the gearmotor (see paragraph 3.6) ensuring that there is no difficulty with this procedure. Ensure that the manual force required to move the pole on opening is no greater than 200 N (approx. 20 Kg); the force is measured perpendicular to the pole and at 1 m from the rotation axis. Lastly, ensure that the key required for manual release is available in the vicinity of the automation.
- 11 **Power supply disconnection system check:** by using the power dis-

connect device, and disconnecting any buffer batteries, ensure that all leds on the control unit are off and that the pole remains stationary when any commands are sent. Check efficiency of the locking device to prevent inadvertent and/or unauthorised reconnection.

5.2 - Commissioning

Commissioning can only be performed after positive results of all test phases. Partial or "makeshift" commissioning is strictly prohibited.

- 1 Compile and provide the automation owner with the "**CE Declaration of conformity - Appendix I**", at the end of this manual, in the removable section.
- 2 Compile and provide the automation owner with the form "**Operation Manual**" at the end of this manual, in the removable section.
- 3 Compile the form "**Maintenance schedule**", containing all maintenance instructions for all devices in the automation and forward it to the owner. In the case of the barrier, this form is present at the end of this manual, in the removable section.
- 4 Before commissioning the automation, ensure that the owner is adequately informed of all associated risks and hazards.
- 5 Permanently affix on the barrier, the label in the pack regarding the gearmotor manual release and locking operations.
- 6 **ONLY for installations NOT IN CONFORMITY** with the criteria stated in chapter 1.3.1 of this manual: produce the technical documentation of the automation, which must include the following documents: an overall drawing of the automation, the wiring diagram of all connections made, an assessment of all risks present and relative solutions adopted (see forms to be compiled on the website www.niceforyou.com), declarations of conformity of the manufacturer of all devices used (for the barrier see appendix II) and the declaration of conformity compiled by the installer.
Affix a dataplate on the barrier, specifying at least the following data: type of automation, name and address of manufacturer (responsible for commissioning), serial number, year of construction and CE mark.

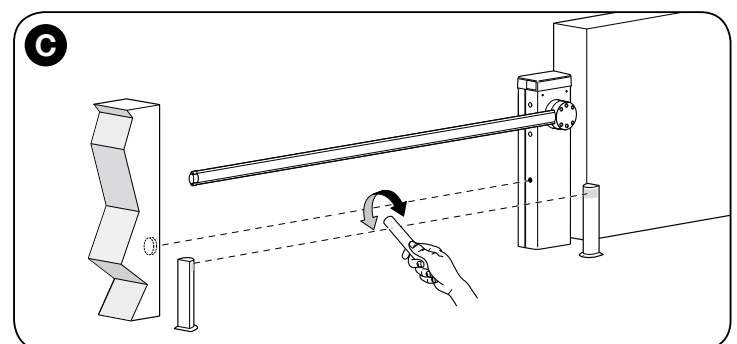
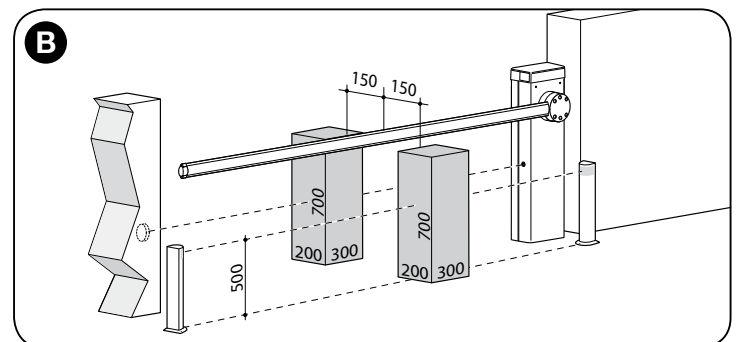
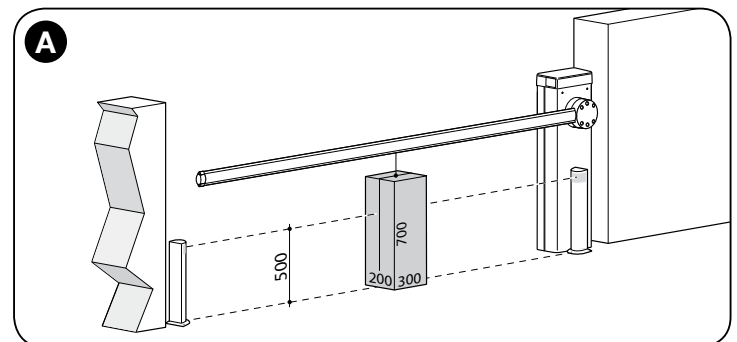

6 CONTROL UNIT PROGRAMMING

The control unit has 3 keys **OPEN (▲)**, **STOP (Set)**, **CLOSE (▼)** (Fig. 49) that can be used both for controlling the unit during testing and for programming the available functions.

The programmable functions available are divided into 2 levels and their relative operating status is displayed by means of the 8 LEDs (L1 ... L8) on the control unit.

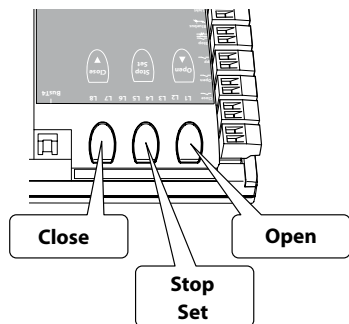

LED SIGNALS:

- **Led lit** = function active;
- **Led off** = function not active.

PROGRAMMING KEYS:

- **OPEN (▲)**: the "OPEN" key enables control of pole opening or can be used, during programming, to move the programming point up.

- **STOP (Set)**: the "STOP" key enables the user to stop the manoeuvre; if pressed for more than 5 seconds, it enables entry to programming mode.
- **CLOSE (▼)**: the "CLOSE" key enables control of pole closing or can be used, during programming, to move the programming point down.

IMPORTANT! – During a manoeuvre (open or close) all 3 keys (▲, Set, ▼) work as STOP; causing the maneuver underway to stop or the reverse of the maneuver.

6.1 - Level one programming (ON-OFF functions)

All the level 1 functions (Table 6) are set by default to "OFF" and may be modified at any time as explained in Table 7. The parameters can be set on a scale from 1 to 8. To check the value corresponding to each LED see Table 6.

IMPORTANT – In the programming procedure, the maximum time interval that can elapse between activation of one key and the next is 10 seconds. When this time elapses, the procedure terminates automatically, memorising the modifications made up until then.

TABLE 6 - First level functions

Led	Description	Example
L1	Automatic closure	This function performs automatic closure of the pole after the programmed pause time. Factory setting: 20 seconds. Value programmable from 3 to 60 seconds.
L2	Reclose after photo	This function enables the pole to remain in Opening position for the time required for transit. When the function is active, operation depends on the parameter set in the function "Automatic closure": <ul style="list-style-type: none"> • with "Automatic closure" active, the Opening manoeuvre stops immediately after the photocells are disengaged and the Closure manoeuvre starts after 5 seconds. • with "Automatic closure" not active, the pole always reaches the maximum Opening position (even if the photocells are disengaged beforehand) and Closure starts after 5 seconds.
L3	Always close	This function is useful in the event of a power failure, even brief. In fact if this function is active (ON), when power is restored, the control unit detects the pole as open and starts Closure. For reasons of safety the Closure manoeuvre is preceded by a 3-second pre-flashing interval.
L4	Stand by	This function allows consumptions to be reduced. If active, 1 minute after the end of the manoeuvre, the control unit turns off the TX of the Bluebus photocells and all the LEDs, excluding the Bluebus LED which flashes more slowly. When the control unit receives a command normal operation is restored. For the use of the barrier with the Solemyo system it is necessary to activate an even deeper "Stand by" mode, the "Stand by all". This operation is performed using the Oview programmer.
L5	Long/short deceleration	This function enables the user to double the space for starting deceleration, both in Opening and Closing. If the function is deactivated, deceleration is short.
L6	Automatic start-up	This parameter, if active (ON), lets you activate the start-up (starting at maximum speed) until the pole is made to move. The default value is "OFF".
L7	Modo Slave	By activating this function the barrier becomes "Slave": it is possible to synchronize the operation of 2 counterposed barriers where one works as Master and the other as Slave; for more information see paragraph 7.6 - Master-Slave Mode.
L8	Direction of motor rotation	This parameter enables inversion of the direction of motor rotation to enable barrier installation on the right; the factory setting is "OFF" (standard motor rotation – pole closure on left). Important – If the function is activated, the Opening and Closing positions must be memorised again (Paragraph 4.5).

TABLE 7 - Programming procedure (first level functions)

01. Press and hold down the "Set" key for approx. 3 seconds;	
02. Release the key when LED L1 starts flashing;	
03. Press keys "▲" or "▼" to move from the flashing led to the led associated with the function to be modified;	
04. Press "Set" to change the status of the function: (short flash = OFF; long flash = ON).	
05. Wait 10 seconds (maximum time) to exit the programming mode.	
Note – During this procedure, points 03 and 04 need to be repeated when programming other functions to "ON" or "OFF" during the phase itself.	

6.2 - Level two programming (adjustable parameters)

All level 2 parameters are set by default (Table 8) and may be modified at any time as explained in Table 9.

The parameters can be set on a scale from 1 to 8. To check the value corresponding to each LED see Table 8.

IMPORTANT – In the programming procedure, the maximum time interval that can elapse between activation of one key and the next is 10 seconds. When this time elapses, the procedure terminates automatically, memorising the modifications made up until then.

TABLE 8 - Second level functions

Input LED	Parameter	LED (level)	Value	Description
L1	Time Pause	L1	3 seconds	Sets the pause time, i.e. the time that passes between the end of an opening manoeuvre and the start of an automatic closing manoeuvre This parameter is only effective if the "automatic Closure" is active.
		L2	5 seconds	
		L3	7 seconds	
		L4	10 seconds	
		L5	15 seconds	
		L6	20 seconds	
		L7	40 seconds	
		L8	60 seconds	
L2	Function Step by step	L1	Open – stop – close - stop	Sets the sequence of commands associated with the input or the radio control: "Step by step".
		L2	Open – stop – close - open	
		L3	Open – close – open - close	
		L4	Apartment block 1	
		L5	Apartment block 2	
		L6	Step by step 2	
		L7	Hold-to-run	
		L8	Opening in semi-automatic mode, closing in dead man mode	
L3	Speed Motor	L1	Speed 1 (50%)	Sets the motor speed during normal travel.
		L2	Speed 2 (80%)	
		L3	Speed 3 (100%)	
		L4	Open V3, Close V1	
		L5	Open V1, Close V2	
		L6	Open V2, Close V3	
		L7	Open V3, Close V2	
		L8	Open V2, Close V1	
L4	1 LIGHT Output	L1	Pole Open Indicator (24 V - 10 W)	Selects the type of device connected to the LIGHT output. Important! – If the programmed setting is modified, check the type of voltage of the new device connected to the LIGHT terminal and ensure that it corresponds to the type of voltage of the selected programming level.
		L2	Pole closed (24 V - 10 W)	
		L3	Pole open (24 V - 10 W)	
		L4	Flashing light(12 V - 21 W)	
		L5	Flashing light 1 (24 V - 10 W) (for pole lights)	
		L6	Electric lock(24 V - 10 W)	
		L7	Suction cup(24 V - 10 W)	
		L8	Maintenance indicator (24 V - 10 W)	
L5	Led Output (cover lights)	L1	Flashing light (only during the manoeuvre)	Select the operating mode of the device connected to the LED output. Modes from L1 to L4 can be associated to the LED flashing light device. Modes from L5 to L8 can be associated to the LED traffic light device. Important! – Never connect devices other than those specified.
		L2	Flashing light 1 (always flashing)	
		L3	Courtesy light	
		L4	Always lit	
		L5	Red traffic light	
		L6	Green traffic light	
		L7	One-way traffic light	
		L8	Two-way traffic light	
L6	Motor force	L1	Force 1 (low)	During the movement, adjust the control system of the motor force to adapt it to the weight of the pole.
		L2	Force 2	
		L3	Force 3	
		L4	Force 4	
		L5	Force 5	
		L6	Force 6	
		L7	Force 7	
		L8	Force 8 (high)	
L7	Loop Detector Sensitivity	L1	100% - maximum	Adjust the detection sensitivity of the metal objects of the Loop Detector circuit. See paragraph 7.5 - chap. 7 Further details.
		L2	90%	
		L3	80%	
		L4	70%	
		L5	60%	
		L6	50%	
		L7	40%	
		L8	30% - minimum	
L8	Braking	L1	0 - absent	Set the intensity of the braking carried out during the deceleration phase of the manoeuvre.
		L2	1	
		L3	2	
		L4	3	
		L5	5	
		L6	6	
		L7	8	
		L8	9 - maximum	

WARNINGS:

- Do not set an excessively high value for the "motor force" as this may impair operation of the safety system or damage the pole;
- If the "Motor force control" is used in support of the system for impact force reduction, after each adjustment the force measurement procedure must be performed, as envisaged by standard EN 12445.
- Wear and atmospheric conditions influence movement of the pole; motor force settings should be checked periodically.

TABLE 9 - Programming procedure (second level functions)

01. Press and hold down the “Set” key for approx. 3 seconds;	
02. Release the key when LED L1 starts flashing;	
03. Press keys “▲” or “▼” to move from the flashing led to the led associated with the function to be modified;	
04. Press and hold the “Set” key through to completion of point 06;	
05. Wait approx. 3 seconds, until the LED representing the current level of the parameter to be modified illuminates;	
06. Press keys ▲ or ▼ to move the LED representing the value of the parameter;	
07. Release the “Set” key;	
08. Wait 10 seconds (maximum time) to exit the programming mode.	
Note – During this procedure, points 03 to 07 need to be repeated when programming other parameters during the phase itself.	

7 FURTHER INFORMATION

7.1 - Total deletion of control unit memory

It is possible to delete all memorised data on the control unit and reset it to the original factory settings:

01. Press and hold down “▲” and “▼” keys at the same time;
02. Release the keys when all Led illuminate (after approx.3 seconds);

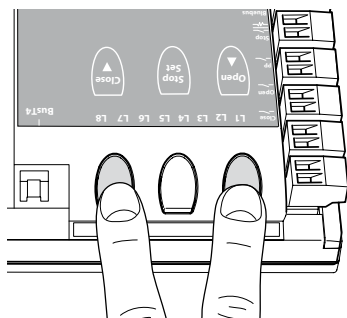

03. When leds L1 and L2 start flashing, this means that the procedure is terminated.

Note – With this procedure it is also possible to delete any errors remaining in the memory.

Important – This procedure does not delete the parameter regarding the direction of motor rotation and the number of manoeuvres performed.

7.2 - Other functions

• “Always open” function

This function is a special feature of the control unit; it is associated with the “Step Step” input and enables an “always open” command when the Step Step command remains active for more than 3 seconds. This function is valid for any setting of the Step Step input (see “SS Function” in **Table 8**).

For example, it can be used to connect a clock for programming permanent opening of the barrier during a specific time band.

• “Move anyway” function

If one or more safety devices malfunctions or is out of service, this function enables control of the barrier in “hold-to-run” mode (for details, see chapter “operation manual”).

• “Maintenance notification” function

This function enables notification of when an automation maintenance check is necessary. The “Maintenance notification” parameter can be set by using the Oview programmer. The maintenance notification is signalled via the Flash flashing light or by the maintenance indicator according to the type of setting. The signals emitted by the Flash flashing light and the maintenance indicator are shown in **Table 10**.

• Check of number of manoeuvres performed

To check the number of manoeuvres performed, the Oview programmer is required; parameters that can be checked under the item “Maintenance”.

• Manoeuvre counter reset

The manoeuvres can be reset at the end of the automation maintenance phase and must be carried out by **deactivating** the “Maintenance indicator” function related to the LIGHT output.

Note - Temporarily disconnect the device connected to the 1 LIGHT output.

Procedure to **activate** the Maintenance indicator (when **it is not already active**):

01. Press and hold down the “Set” key for approx. 3 seconds;
02. Release the key when LED “L1” starts flashing;
03. Press the key “▲” or “▼” to move from the LED that is flashing to LED L4 (“LIGHT output” input LED);
04. Press and hold the “Set” key through to completion of point 07;
05. Wait approx. 3 seconds, until the LED of the programmed output illuminates;
06. Press keys “▲” or “▼” to move the lit LED on L8;
07. Release the key “Set” and wait for the output for the timeout from the programming procedure.

Procedure to **deactivate** the Maintenance indicator (when **it is not already active**):

01. Press and hold down the “Set” key for approx. 3 seconds;
02. Release the key when LED “L1” starts flashing;
03. Press the key “▲” or “▼” to move from the LED that is flashing to LED L4 (“LIGHT output” input LED);
04. Press and hold the “Set” key through to completion of point 07;
05. Wait approx. 3 seconds, until LED L8 illuminates;
06. Press keys “▲” or “▼” to move the lit LED on a LED other than L8;
07. Release the key “Set” and wait for the output for the timeout from the programming procedure.

Now the maintenance notification has been cancelled.

Note – Reset the programming of the LIGHT output with the device to be used and then reconnect it to the output.

TABLE 10

Number of manoeuvres	Flash flashing light	Maintenance indicator
Below 80% of the limit	Normal (0.5 sec. lit - 0.5 sec. off)	Light on for 2 seconds at the start of the opening manoeuvre.
Between 81% and 100% of the limit	Light on for 2 seconds at the start of the manoeuvre, then continuing as normal	Flashing for entire duration of manoeuvre
Over 100% of the limit	At the start and end of the manoeuvre, remains lit for 2 sec., then continues as normal.	Always flashes

7.3 - Adding or removing devices

New devices can be added at any time, connected to the BlueBus and Stop input or those present can be deleted as required. To do this, proceed as follows:

01. Press and hold down “▲” and “Set” keys at the same time;
02. Release the buttons when LEDs L1 and L2 start flashing very quickly (after approx. 3 s);
03. Wait a few seconds for the control unit to finish connected device self-learning;
04. At the end of this phase, the STOP LED must remain lit, while LEDs L1 and L2 turn off (where relevant LEDs L3 and L4 start flashing).

After performing this procedure, the automation testing procedure must be performed as described in chapter 5.1.

7.3.1 - Bluebus Inlet

This Bluebus system allows device connections to be made using just 2 conductors for both the electricity supply and the communication signals. All devices are connected in parallel on the same 2 Bluebus wires, without the need to observe polarity. Each device is individually recognized because a unique address is assigned to it during installation. Bluebus can be used to connect the following: photocells, safety devices, control devices such as key-boards and readers for transponder cards, indicator lamps, etc. The control unit recognises each one of the devices connected during the self-learning phase and is able to detect all possible faults in maximum safety. For this reason each time a device is connected to or removed from Bluebus the self-learning phase must be repeated, as described in paragraph 4.4.

7.3.2 - Photocells

The Bluebus system enables the control unit to recognise the photocells, control routing of the relative jumpers (see **Table 11**) and enables assignment of the correct value for the obstacle detection function. The routing operation is performed both on TX and RX, positioning the jumpers in the same way with a check that there are no pairs of photocells with the same address.

The photocells may be installed as shown in **fig. D**. **Important** – After installing or removing the photocells, the device learning phase must be performed, as described in paragraph 4.4.

It is possible to install the TX or RX photocell inside the caisson of the barrier, in the space provided (**fig. 53**).

To install the photocell, proceed as follows:

01. Extract the board of the photocell from its box by prizing it out with a slotted tip screwdriver (**fig. 53-a**). **IMPORTANT!** - Do not damage the electric components inside;
02. Open the box prepared for the photocells, present in the accessory box (**fig. 53-b**);
03. Block the board on the bottom of the box (**fig. 53-c**);
04. Pierce the rubber arranged for the passage of the electric cable (**fig. 53-d**);
05. Route the electric cable and connect it to the terminal of the photocell (**fig. 53-e**);
06. Close the bottom of the box with the cover, taking care to block the rubber in its seat (**fig. 53-f**);
07. Hook the box on the lens on the side of the caisson by making it slide from top to bottom (**fig. 53-g**).

NOTE – 2 photocells with control function “opens FA1” and “opens FA2” can be connected to the Bluebus input (it is necessary to cut the A jumper at the rear of TX and RX cards). When these photocells intervene, the control unit commands an opening manoeuvre. For further information, refer to the instruction manual for the photocells.

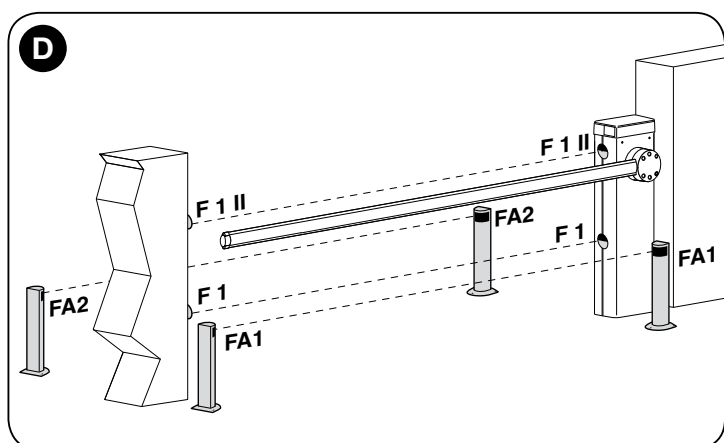

TABLE 11 - PHOTOCCELL ADDRESSES

Photocell	Jumpers	
PHOTO	Photocell h = 50 activated on closure	
PHOTO II	Photocell h = 100 activated on closure	
PHOTO 1	Photocell h = 50 activated on closure	
PHOTO 1 II	Photocell h = 100 activated on closure	
PHOTO 2	Photocell activated on opening (inverts on closing)	
PHOTO 2 II	Photocell activated on opening (inverts on closing)	
PHOTO 3	Single photocell activated on opening and closing	
FA1	Photocell for opening command (cut the A jumper at the rear of TX and RX cards)	
FA2	Photocell for opening command (cut the A jumper at the rear of TX and RX cards)	

7.3.3 - MOTB digital selector and proximity reader for MOMB transponder cards

The Bluebus system enables connection of up to 4 MOTB digital selectors or 4 MOMB transponder badge readers.

MOTB enables control of the automation, by entering one of the memorised numerical codes on the keypad.

MOMB enables control of the automation by simply placing the memorised transponder badge close to the automation.

These devices have an individual code, which is recognised and memorised by the control unit during the phase for learning all connected devices (see paragraph 4.4).

This prevents an fraudulent attempts to replace a device or use of the automation by unauthorised persons. For further information, refer to the instruction manual for MOTB and MOMB.

7.3.4 - STOP Input

The Stop input causes the manoeuvre to stop immediately followed by a short reverse run. Devices with normally open NO or normally closed NC contact outputs, optical devices (Opto Sensors), or devices with 8.2 kΩ constant resistance output such as sensitive edges can be connected to this input. The control unit, during the learning phase, recognises the type of device connected and activates a STOP command when any variation in the learnt status occurs. When set accordingly, more than one device can be connected to the STOP input, also different from one another;

- Several NO devices can be connected in parallel, with no limit to the number;
- Several NO devices can be connected in series, with no limit to the number;
- Two devices with an 8.2kΩ constant resistance output can be connected in parallel; multiple devices must be connected “in cascade” with a single 8.2kΩ termination resistance;
- An NO and NC type combination is also possible, placing the 2 contacts in parallel. In this case, a 8.2 kΩ resistance must be placed in series with the NC contact; this also enables the combination of 3 devices: NO, NC and 8.2 kΩ.

Caution – If the STOP input is used to connect devices with safety functions, only the devices with a constant resistance of 8.2 kΩ or OPTO SENSOR optical devices guarantee adequate safety levels against faults.

For connection of an optical device type OPTO SENSOR make the connections as shown in **fig. E**. The maximum current provided on the 12 Vdc line is 40 mA.

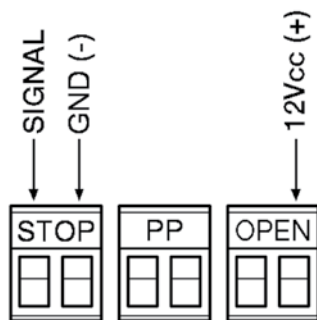

7.4 - Diagnostics

Some devices are able to emit signals that serve to recognise their state of operation or possible faults.

7.4.1 - Signals of control unit

The LEDs of the terminals and the keys on the control unit emit special signals both to indicate normal operation and possible faults. Tables 12 and 13 describe the cause and solution for each type of signal.

TABLE 12 - Terminal LEDs on control unit

Led Bluebus	Cause	Solution
Off	Fault	Check for presence of the power supply; check that the fuses are not blown; in this case, identify the cause of the fault and then replace with versions with the same specifications.
On	Serious fault	This indicates a serious fault; try switching off the control unit for a few seconds; if the condition persists there is a fault and the electronic board needs to be replaced.
1 flash per second	All OK	Normal operation of control unit.
2 quick flashes	Input status variation	A variation to the status of the inputs SS, STOP, OPEN, CLOSE, activation of the photocells, or when the radio transmitter is used, is normal.
Series of flashes separated by	Various	This is the same signal of 1 second as on the flashing light (See table 15).
Led STOP	Cause	Solution
Off	STOP input activation	Check the device connected to the STOP input
On	All OK	STOP input active
Led PP	Cause	Solution
Off	All OK	S.S. Input not active
On	S.S. input activation	Normal if the device connected to the S.S. input is active
Led OPEN	Cause	Solution
Off	All OK	OPEN input not active
On	OPEN input activation	Normal if the device connected to the OPEN input is active
Led CLOSE	Cause	Solution
Off	All OK	CLOSE input not active
On	CLOSE input activation	Normal if the device connected to the CLOSE input is active
FC1 limit switch LED	Cause	Solution
Off	Limit switch activation	- If the parameter "Standard motor rotation direction" is set, the pole is in the total closing position. - If the parameter "Inverted motor rotation direction" is set, the pole is in the total opening position.
On	Limit switch not activated	- If the parameter "Standard motor rotation direction" is set, the pole is in a position other than the total closing position. - If the parameter "Inverted motor rotation direction" is set, the pole is in a position other than the total opening position.
FC2 limit switch LED	Cause	Solution
Off	Limit switch activation	- If the parameter "Standard motor rotation direction" is set, the pole is in the total opening position. - If the parameter "Inverted motor rotation direction" is set, the pole is in the total closing position.
On	Limit switch not activated	- If the parameter "Standard motor rotation direction" is set, the pole is in a position other than the total opening position. - If the parameter "Inverted motor rotation direction" is set, the pole is in a position other than the total closing position.
Led encoder	Cause	Solution
Off	The magnet is in front of the sensor	If there is no manoeuvre in progress it is normal, otherwise there is a fault in the encoder or the cable is not connected properly
On	The magnet is not in front of the sensor	If there is no manoeuvre in progress it is normal, otherwise there is a fault in the encoder or the cable is not connected properly
Flashing light	Manoeuvre in progress	All OK if the manoeuvre is in progress; the flashing is proportional to the speed. <i>Note – During the execution of the manoeuvre, the flashing speed could appear as LED on.</i>

TABLE 13 - Button LEDs on control unit

Led 1	Description
Off	During normal operation, indicates "Automatic closure" not active.
On	During normal operation, indicates "Automatic closure" active.
Flashes	<ul style="list-style-type: none"> • Programming of functions in progress. • If this flashes together with L2 this indicates that the device learning phase must be performed (see paragraph 4.4).
Quick flash	After control unit start-up, it indicates a memory error regarding the <u>devices connected</u> . At the same time, the "Bluebus" led emits a diagnostic signal: 5 flashes - pause of 1 second - 5 flashes. In this case the learning phase for connected devices must be performed (see paragraph 4.4) or delete the memory (see paragraph 7.1).
Led 2	Description
Off	During normal operation, indicates "Re-close after photo" not active.
On	During normal operation, indicates "Re-close after photo" active.
Flashes	<ul style="list-style-type: none"> • Programming of functions in progress. • If this flashes together with L1 this indicates that the device learning phase must be performed (see paragraph 4.4).
Quick flash	After control unit start-up, it indicates a memory error regarding the <u>positions</u> . At the same time, the "Bluebus" led emits a diagnostic signal: 5 flashes - pause of 1 second - 5 flashes. In this case the learning phase for the Opening and Closing positions must be performed (see paragraph 4.5) or delete the memory (see paragraph 7.1).
Led 3	Description
Off	During normal operation, indicates "Re-close after photo" not active.
On	During normal operation, indicates "Re-close after photo" active.
Flashes	<ul style="list-style-type: none"> • Programming of functions in progress. • If this flashes together with L4 this indicates that the device learning phase of the opening and closing positions of the pole must be carried out (see paragraph 4.5).
Quick flash	After control unit start-up, it indicates a memory error regarding the <u>parameters and configurations</u> . At the same time, the "Bluebus" LED emits a diagnostic signal: 5 flashes - pause of 1 second - 5 flashes. In this case it is necessary to delete the memory (see paragraph 8.1), the learning of the connected devices (see paragraph 4.4) and the learning of the opening and closing positions (see paragraph 4.5).
Led 4	Description
Off	During normal operation, indicates "Stand-BY" not active.
On	During normal operation, indicates "Stand-BY" active.
Flashes	<ul style="list-style-type: none"> • Programming of functions in progress. • If this flashes together with L3 this indicates that the device learning phase of the opening and closing positions of the pole must be carried out (see paragraph 4.5).
Quick flash	A short circuit or an over absorption in one of the 3 terminal outputs has been detected. Check the connections and the devices connected to the various outputs.
Led 5	Description
Off	During normal operation, indicates "Short deceleration" active.
On	During normal operation, indicates "Long deceleration" active.
Flashes	Programming of functions in progress.
Quick flash	There is an error in the encoder calculation since one or more magnets are not read or the cable is not connected or it is the third consecutive manoeuvre where the "Obstacle detection" function activates. Check that all the magnets are read and the cable is connected and in good condition.
Led 6	Description
Off	During normal operation, indicates "Pre-flash" not active.
On	During normal operation, indicates "Pre-flash" active.
Flashes	Programming of functions in progress.
Quick flash	<ul style="list-style-type: none"> - The limit switches are inverted. Invert the wiring of the limit switches or check that the parameter "direction of motor rotation" is set. - After sending a movement command, the limit switch has not been freed by the set time: make sure that there is no hindrance to the movement; the "start-up" function may be activated if necessary.
Led 7	Description
Off	During normal operation, indicates "Current sensitivity control" not active.
On	During normal operation, indicates "Current sensitivity control" active.
Flashes	Programming of functions in progress.
Quick flash	Error in the Master/Slave communication. Check whether the cable is connected or check the polarity of the Master/Slave connection cable or check that the Master/Slave acquisition phase for both control units has been carried out (see paragraph 7.6 – "Master/Slave").
Led 8	Description
Off	During normal operation it indicates that Pole closing is set to the left.
On	During normal operation it indicates that Pole closing is set to the right.
Flashes	Programming of functions in progress.
Quick flash	Barrier version error. The type of barrier does not coincide with the version saved in the control unit. Check that the version wiring is in good condition and connected correctly. If the error continues, delete the memory and install again.

7.4.2 - Flashing light signals

If a flashing light is connected to the FLASH output on the control unit (or the LED flashing light is used, optional accessory), during the performance of a manoeuvre this emits a flash each second. If faults occur, the flashing light will

emit shorter flashes; these are repeated twice, separated by a 1 second pause. The same signals are also emitted by the LED flashing light (optional accessory) and the "Bluebus" LED. Table 14 shows the cause and solution for each type of signal.

TABLE 14

Signal	Cause	Solution
1 flash second pause 1 flash	Bluebus system error	At the start of the manoeuvre, the devices connected to Bluebus do not correspond to those recognized during the self-learning phase. One or more devices may be faulty; check and, if necessary, replace them. In case of modifications repeat the device self-learning process (see paragraph 4.5).
2 flashes second pause 2 flashes	Photocell activated	At the start of the manoeuvre, one or more photocells do not enable it; check to see if there are any obstacles.
3 flashes second pause 3 flashes	Activation of Motor Force limiter	During the movement, the pole has experienced excessive friction; identify the cause.
4 flashes second pause 4 flashes	STOP input activation	At the start of the manoeuvre or during the movement, the STOP input was activated; identify the cause.
5 flashes second pause 5 flashes	Error on internal parameters in control unit	Switch off the power and turn it on again. If the error continues carry out the "Total deletion of the memory" as described in chapter 7.1 and redo the installation; if the condition persists, there may be a serious malfunction and the electronic board must be replaced.
6 flashes second pause 6 flashes	Not used	—
7 flashes second pause 7 flashes	Error in internal electric circuits	Disconnect all power circuits for a few seconds and then retry a command; if the condition persists this may indicate a serious fault with the board or motor wiring. Check and make replacements as necessary.
8 flashes second pause 8 flashes	Not used	—
9 flashes second pause 9 flashes	Block automation	Send the command "Release automation" or control the manoeuvre with "High Priority Step Step".

7.5 - Loop Detector

The control unit has two circuits used to detect metal masses (motorcycles, cars, trucks, etc...); each circuit may be completed with the use of an inductive loop, consisting of 1 unipolar cable, to be positioned below the ground at a depth of a few centimeters.

7.5.1 - Operation

When the control unit detects a variation in frequency with the passage of a metal mass above the loop, it activates a manoeuvre or an output (output 1, 2, 3) to activate the flashing light, the open barrier indicator or the lights for the pole. The factory setting controls an opening manoeuvre of the pole; until the loop is operating, it is not possible to control the closing manoeuvre.

When the control unit is powered, it carries out a calibration, i.e. a measurement of the operating frequency of each loop; if no loop is connected to the control unit, the circuit automatically turns off after 30 seconds.

There are 8 levels of "metal mass detection sensitivity" (see Table 7 chapter 6). The factory setting is 90%.

By using the Oview programmer, it is possible to modify the other parameters and operating modes associated to the Loop Detector.

The following programs are possible, also see Table 15 for the values:

- **Loop sensitivity:** set the minimum frequency variation of the metal mass, required to activate the manoeuvre. Reference parameters:
 - set a "high sensitivity" for the detection of small sized metal masses
 - set a "low sensitivity" for the detection of large sized metal masses.
- **Loop power supply:** activates or deactivates the circuits of the loop detector.
- **Activate loop 1, 2:** the activation of the loop makes the movement of the barrier activate according to the set operating mode. If the function is DEACTIVATED, the status of the loop is available, by suitably programming one of the outputs (output 1, 2, 3) on the control unit, with the Oview programmer.
- **Loop permanence time:** time during which the loop is occupied. Once this time has passed, a recalibration is automatically activated to signal the free loop.
- **Loop operation mode:** if the function "Loop active" is enabled and the loop command signal is ACTIVE, the behaviour of the barrier varies according to the set "loop operation mode":

- only opens (apartment block opens)
- only closes
- alt
- photo closes (PHOTO with total inversion)

• **Calibration:** starts a calibration procedure; i.e. acknowledgement of the connected loop. Note: the calibration automatically activates the parameter "Loop power supply"

• **Activation modes:** see Table 16 (relay = loop command signal).

• **Loop activation time:** is the time "t" linked to the operating modes described in Table 16.

• **Loop frequency display:** signals the fluctuation frequency of the loop selected in Hz.

7.5.2 - Installation

WARNINGS

- It is advisable to install the magnetic loop near the barrier.
- The electric cables of the magnetic loops must be separated from the other cables in the barrier (power supply, accessories, etc.).
- If the magnetic loops are connected to other barriers, it is necessary to position them at least 1 m between each other.
- **Important!** – The magnetic loop must be fixed in a way to make it immobile since any movement caused by an unstable floor could cause false tripping.
- The size of the loop must be defined depending on the application; it is necessary to consider that the loop must be positioned at a distance of at least 20 cm from fixed metal objects and 1 m from moving metal objects (**fig. F**). Note – To obtain optimal operation, it is worth using a loop that is the same size as or smaller than the object to be detected.
- Usually the loop used for the passage of cars and trucks is rectangular in shape, to be positioned 45° with respect to the route arranged for the passage of bicycles and motorbikes (**fig. G**). Note – We recommend you cut the 45° corners of the outline on the floor to avoid breaking the cable.
- **IMPORTANT – TO PREVENT INTERFERENCE, THE CONNECTION CABLES OF THE LOOP MUST BE TWISTED AT LEAST 20 TIMES A METER AND THERE MUST BE NO JOINTS.** Should it be necessary to extend the cable, weld the conductors and seal them with the thermo-shrinkable sheath. **The length of the twisted cable must be less than 20 m.**

01. After determining the size of the loop, dig a groove in the floor of a width = 8 mm and a depth = 30-50 mm (**fig. H**);
02. Clean the groove and insert the loop, trying to compact it in a way to avoid it moving;
03. Carry out the number of turns of the loop depending on the perimeter, as indicated in **Table 17**: use a 1.5 mm² unipolar isolated copper cable (**fig. H**);
04. Before sealing the groove, check that the value of the inductive loop is between 100 and 400 μ H or, through the Oview programmer, check that the value of the measured frequency (Parameter "Loop Frequency") is between 30 and 100 KHz;
05. Cover the loop with sand to protect it and then seal the groove with bitumen or resin for outdoor use (**fig. H**). **Important!** – The temperature of the sealant must not exceed the maximum temperature admitted for the isolation of the cable, otherwise a loss in isolation towards the earth may occur.
06. The electric cables must be connected to the **Loop1 (fig. I)** and **Loop2**

(**fig. L**) terminals. The Loop2 terminal presents 2 connection possibilities (**fig. L**); based on the type of connection used, it varies the working frequency of the loop.

Important! – If Loop1 is positioned near Loop2 and both work at the same frequency (or almost), interference could be generated; in this case, it is necessary to change the connection to Loop2 terminal.

TABLE 15

Function	Values	Default
Loop 1 sensitivity	10 – 100%	90%
Loop 2 sensitivity	10 – 100%	90%
Loop power supply	on – off	on
Loop 1 active	on – off	on
Loop 2 active	on – off	on
Loop 1 operating mode	1 – 5	1
Loop 2 operating mode	1 – 5	1
Loop 1 permanence time	2 – 20 = always	20 = always
Loop 2 permanence time	2 – 20 = always	20 = always
Output function 1, 2, 3: Active out (1,2,3) for loop 1	selectable	off
Output function 1, 2, 3: Active out (1,2,3) for loop 2	selectable	off
Calibration [also carried out upon start-up]	on – off	
Loop 1 activation mode*: Loop 1 time	1 – 5 0 – 25 s	1 2s
Loop 2 activation mode*: Loop 2 time	1 – 5 0 – 25 s	1 2s
Loop 1 frequency display	0 - 127000	-
Loop 2 frequency display	0 - 127000	-

TABLE 16

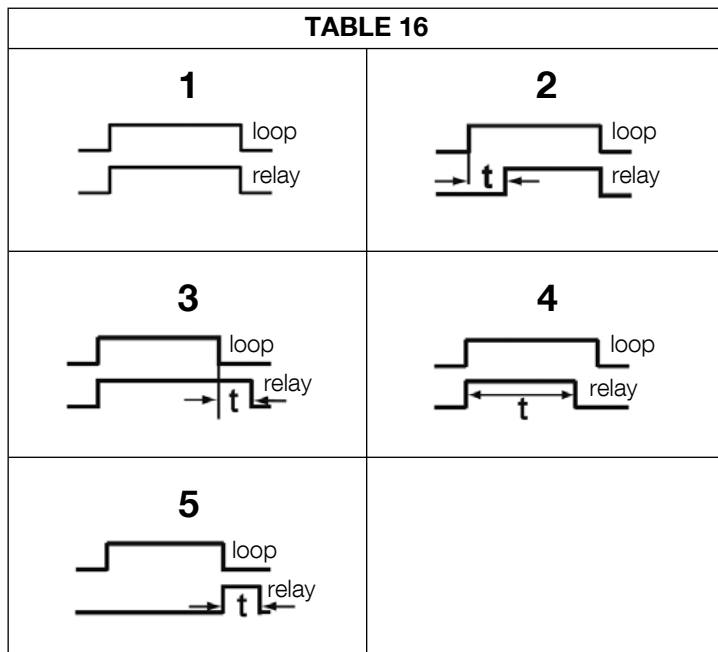
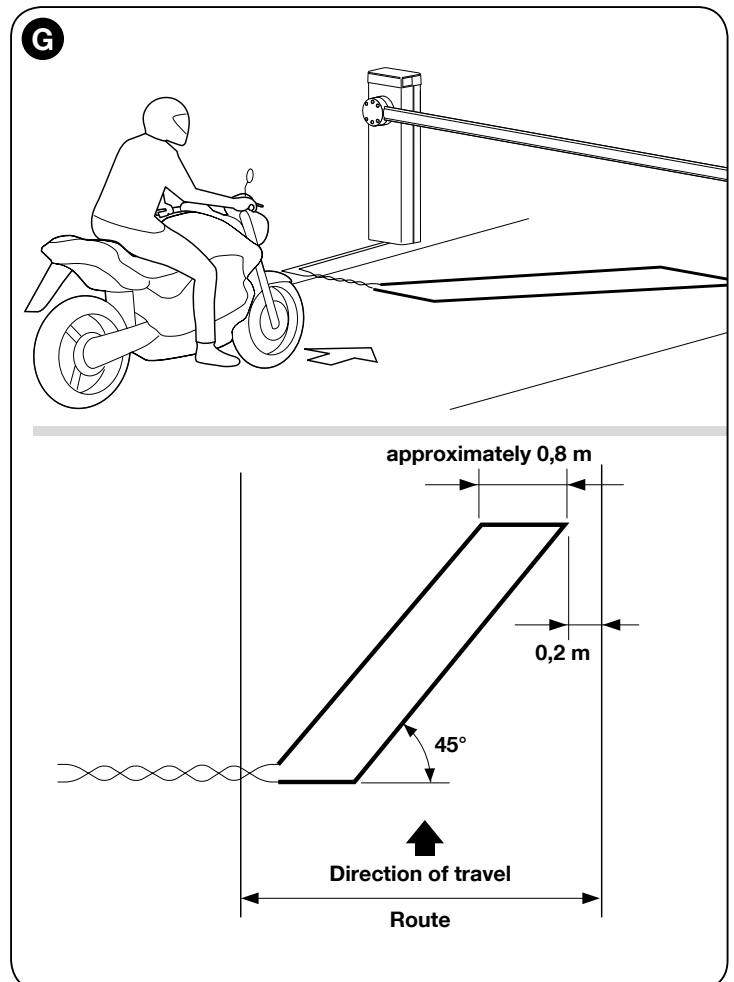
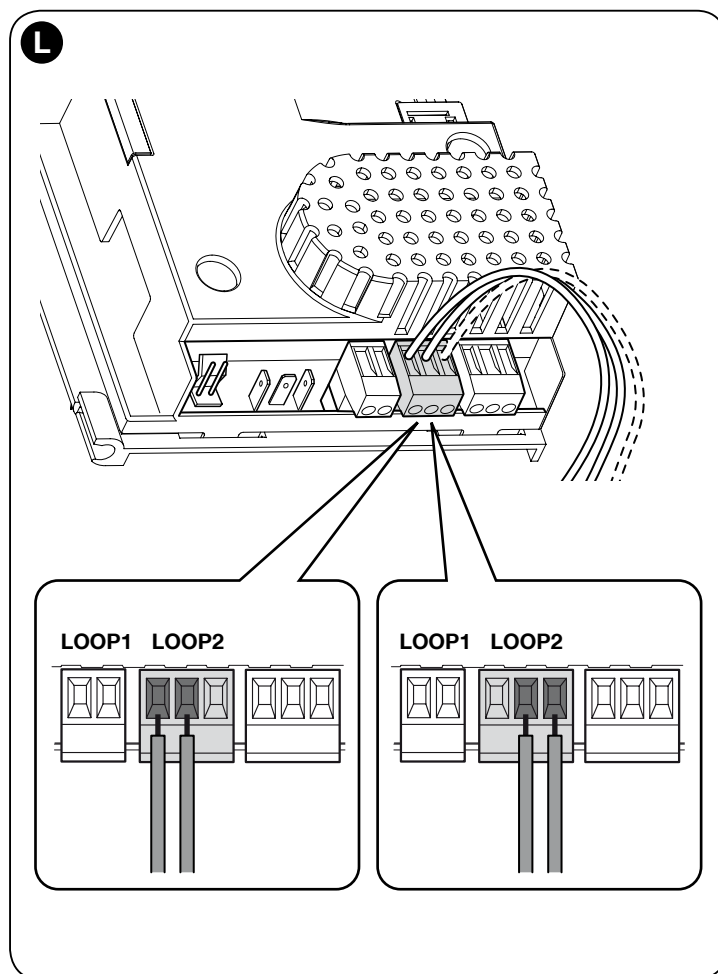
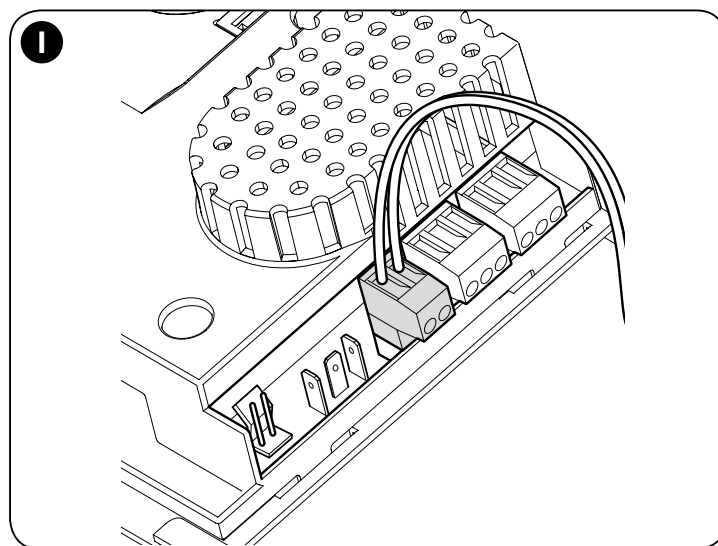
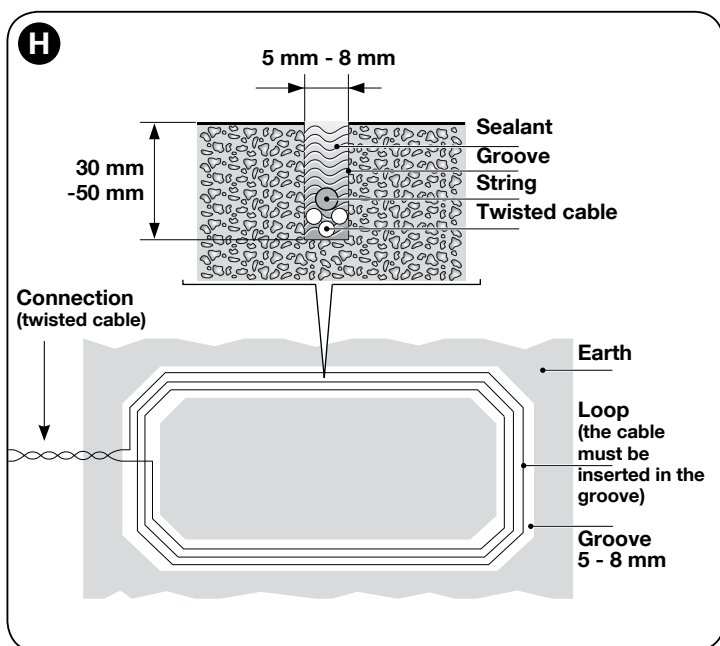
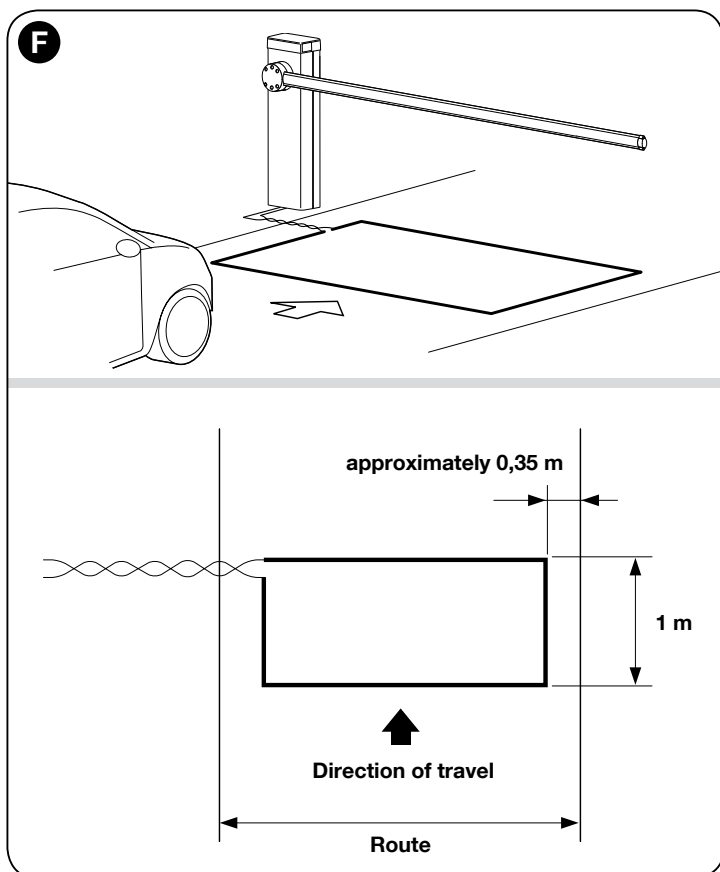

TABLE 17

Perimeter of the loop	Number of turns to be carried out
2 – 4 m	6
4 – 7 m	5
7 – 12 m	4
more than 12 m	3

Note – If in the loop positioning place, below the floor, there are some metal reinforcements, the inductivity of the loop is reduced. In this case, it is necessary to add 2 turns to the twisting of the cable





7.6 - Master - Slave mode

This operating mode is used if it is necessary to automate 2 counterposed barriers which perform synchronised movements. In this mode, a barrier works as Master and commands the manoeuvres, while the second works as Slave and carries out the commands sent from the Master barrier; by default all the barriers are set as Master.

To configure the barrier as Slave it is necessary to activate the level 1 function "Slave Mode" (see Table 7).

The connection between Master and Slave takes place through the BusT4 with the dedicated Master/Slave connector.

Important! – Should the Oview programmer be used, it is necessary to modify the parameter "Griup" or "Address" of one of the 2 barriers. This is to avoid the simultaneous communication of the 2 control units with the Oview programmer.

7.6.1 - Installation and electrical connections

Warnings

- All the devices, including the radio receiver, must be connected on the Master barrier;
- If the buffer battery is used, each barrier must have its own;
- In the **Slave** barrier it is possible to carry out the following connections:

- its own flashing light (Flash)
- its own Pole Open Indicator (S.C.A.)
- pole lights
- its own sensitive edge (Stop)
- its own command device (P.P.), which commands the total opening of the Slave pole only
- the Open and Close inputs are not used
- the Loop1 and Loop2 inputs programmed with "Open" mode
- the receiving radio

To install 2 barriers and program them with "Master - Slave" mode, proceed as follows:

- 01.** Install the 2 barriers (**fig. M**).
It is not important which of the two works as Master or Slave; it is necessary to assess the convenience to create the electrical connections and that the "Step-Step" command that will carry out the Slave barrier will provide the total open **of the Slave pole only**;
- 02.** Connect the two control units one to the other through the Master/Slave connector (**fig. 54**), respecting the polarity indicated;
- 03.** At this point, carry out the other electrical connections (**fig. 54**), referring to the indications contained in chapter 4 - Electrical connections;

04. Once all the electrical connections are done, power each control unit and for each one, follow the procedure described in paragraph 4.2 - Initial start-up and electrical connections.

Important! – Should the Oview programmer be used, it is necessary to modify the parameter “Group” or “Address” of one of the 2 control units of the barrier; this is to avoid that the 2 control units communicate with Oview at the same time.

05. In the **Slave barrier**, carry out the following programming:

- a) Recognition of the connected devices (see paragraph 4.4)
- b) Recognition of opening and closing positions (see paragraph 4.5)
- c) Carry out any adjustments
- d) Activate the “Slave Mode” parameter as described in paragraph 6.1 - Level one programming (ON-OFF).

At this point, LED **L7** starts flashing to signal a “Master-Slave communication error”. This is because the coupling of the Master barrier with the Slave barrier has not yet been carried out.

Important! - In the counterposed barrier, before carrying out “the opening and closing learning phase”, **it is necessary to set the “Direction of motor rotation”** (parameter L8 - Table 7, paragraph 6.1);

Important – Consider that during operation, any programming on the Slave barrier is ignored, since the programming on the Master barrier prevails, excluding that reported in **Table 18**, which only affects the Slave barrier.

06. In the **Master barrier**, carry out the following programming:

- a) Recognition of the connected devices (see paragraph 4.4)
 - b) Recognition of opening and closing positions (see paragraph 4.5)
 - c) carry out any adjustments;
07. Finally, **from the Master control unit**, send a command to carry out a manoeuvre and check that the latter is also carried out by the Slave barrier.

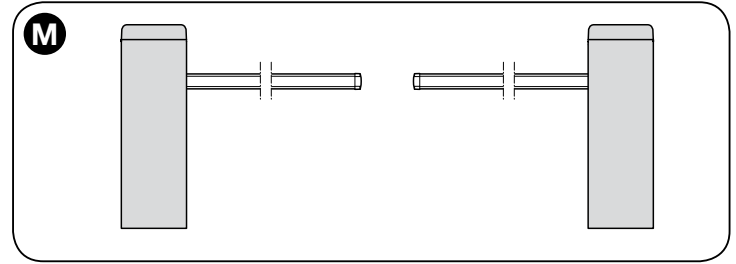

TABLE 18

Level one functions (ON-OFF functions)	Level two functions (adjustable parameters)
Stand-by	Motor Speed
Start-up	Flash Output
Slave Mode	LED output
Long/short deceleration	Motor force
Direction of motor rotation	Braking

Note – Should you decide to use the “total standby” function in the barriers with the Master-Slave configuration, it is necessary to carry out the electrical connection using the BusT4 connector and **not the Master-Slave connector**.

8 WHAT TO DO IF... (troubleshooting guide)

Possible causes of malfunctions are listed below, which may occur during the installation phase, or in the case of faults, possible remedies:

- **The radio transmitter does not control the barrier and the transmitter LED does not illuminate:** Check that the transmitter batteries are not discharged and replace if necessary.
- **The radio transmitter does not control the barrier but the transmitter LED illuminates:** check that the transmitter is correctly memorised on the radio receiver. Ensure correct emission of the radio signal of the transmitter with the following empirical test: Press a key and place the LED against the aerial of a standard radio switched on and tuned to FM at the frequency of 108.5Mhz or as close to this value as possible; a slight noise with a scratching pulse noise should be heard.
- **No manoeuvre is performed when a command is sent, and the OK LED does not flash:** check that the barrier is powered via the mains at 230 V. Also check that the fuses F1 and F2 are not blown; in this case try to locate the cause of the fault and then replace with a version with the same specifications; see **fig. 55**.
- **No manoeuvre is performed when a command is sent, and the flashing light remains off:** check that the command is effectively received; if the sent command reaches the SS input, the OK LED emits a double flash to indicate that the command is received.
- **The manoeuvre does not start and the courtesy light flashes a few times:** count the number of flashes and check against the data in **Table 19**.

TABLE 19

Diagnostics with programming led

L1 fast flash: device memory error
L2 fast flash: position memory error
L3 fast flash: parameter memory error
L4 fast flash: flashing short circuit or courtesy light
L5 fast flash: encoder counting error
L6 fast flash: inverted limit switch error or limit switch not freed by the set time
L7 fast flash: Master/Slave communication error
L8 fast flash: version error

- **The manoeuvre is performed, but shortly afterwards the pole blocks or performs a brief inversion:** the selected force value may be too low to enable the movement of the pole. Check the correct balancing of the pole; if necessary set a higher force value. **The sensitivity value could be too high:** lower the sensitivity value. If the activation takes place in the deceleration phase, it is necessary to decrease the braking intensity.
- **The manoeuvre is carried out at slow speed:** the manoeuvre does not start from one of the limit switches or the control unit does not recognise the limit switch. Check the electrical connection of the limit switch.
- **The Slave barrier does not perform the manoeuvres:** check that the “Master-Slave” learning phase has been carried out on both the barriers.
- **The manoeuvre is carried out in the opposite way:** check that the parameter “Direction of motor rotation” (parameter L8 - Table 7, paragraph 6.1) is set correctly, or invert the motor cables.

PRODUCT DISPOSAL

This product is an integral part of the automation system it controls and must be disposed of along with it.

As in the case of installation, likewise at the end of product lifetime the disassembly and scrapping operations must be performed by qualified personnel.

This product is made of various types of material, some of which can be recycled while others must be scrapped. Seek information on the recycling and disposal methods envisaged by the local regulations in your area for this product category.

Caution! – Some parts of the product may contain polluting or hazardous substances which, if released to the environment, may cause serious damage to the environment or to human health.

As indicated by the symbol alongside, disposal of this product with domestic waste is strictly prohibited. Separate the waste into categories for disposal, according to the methods established by current legislation in your area, or return the product to the retailer when purchasing a new version.

Caution! – Local legislation may impose heavy fines in the event of illegal disposal of this product.



TECHNICAL CHARACTERISTICS OF THE PRODUCT

WARNINGS: • All technical specifications stated in this section refer to an ambient temperature of 20°C (± 5°C). • Nice S.p.a. reserves the right to apply modifications to products at any time when deemed necessary, maintaining the same intended use and functionality.

Model	M3BAR	M5BAR	M7BAR	LBAR
Product Type	Road barrier for residential use complete with electronic control unit			
Useful conduit (m)	2,32 ÷ 2,82	3,17 ÷ 4,82	5 ÷ 7	7 ÷ 9
Maximum torque on start-up (Nm)	100	200	300	400
Nominal torque (Nm)	30	70	90	130
Manoeuvre time (sec adjustable)	1.5 – 4	3 – 6	6 – 10	8 – 12
Maximum operating cycle frequency at nominal torque (the control unit limits the work cycles to the maximum set in table T3)	500 continuous use	350 continuous use	200	150
Durability	See chapter 3 - paragraph 3.2.1			
Power supply voltage	230 Vac 50/60Hz	230 Vac 50/60Hz	230 Vac 50/60Hz	230 Vac 50/60Hz
Power supply voltage /V1	120Vac 50/60Hz	120Vac 50/60Hz	120Vac 50/60Hz	120Vac 50/60Hz
Maximum power absorbed on start-up (W)	150	110	110	160
Maximum power at nominal torque (W)	40	50	40	50
Insulation class	1	1	1	1
Emergency power supply	Yes (with PS224 accessory)			
Photovoltaic power supply	Yes (with SYKCE accessory)			
FLASH output	for 1 LUCYB, MLB or MLBT flashing light signal (12V – 21W)			
LIGHT output	for optional accessory XBA4 “pole lights”			
SCA output	for signal indicator 24V (max 10W)			
Output for flashing light/ traffic light on cover	with optional accessories XBA7 LED flashing light or XBA8 LED traffic light			
BLUEBUS output	1 output with maximum load of 12 Bluebus units			
“STOP” input	For normally closed, normally open, 8.2 kΩ constant resistance or OSE optical type contacts; in self-learning mode (a change from the memorised state prompts the “STOP” command)			
“STEP-STEP” input	For Normally Open contacts			
“OPEN” input	For Normally Open contacts			
“CLOSE” input	For Normally Open contacts			
Radio connector	SM connector for receiver types SMXI, SMXIS, OXI or OXIT			
Radio AERIAL input	50 Ω for RG58 or similar type cable			
Loop Detector Inputs	2 per loop with a circumference from 2 to 16 m			
Nominal Loop inductance	100 to 400 uH			
Programmable functions	8 ON-OFF functions and 8 adjustable functions (see tables 6 and 8) and additional programming through the Programming Unit and Oview Command			
Functions in self-learning mode	Self-learning of devices connected to the BlueBus output. Self-learning of “STOP” type devices (contacts NO, NC or 8.2kΩ resistance). Learning of pole opening and closing positions and calculation of the points of deceleration and partial opening. Self-learning of the “Version”			
Operating temperature	-20°C ÷ +50°C	-20°C ÷ +50°C	-20°C ÷ +50°C	-20°C ÷ +50°C
Use in particularly acid, saline or potentially explosive atmospheres	No	No	No	No
Protection rating	IP54	IP54	IP54	IP54
Dimensions (mm)	400 x 299 x 1215 h	400 x 299 x 1215 h	400 x 299 x 1215 h	500 x 299 x 1215 h
Weight	80 kg	80 kg	85 kg	98 kg

APPENDIX I

To be used only in the case of installations in conformity with chapter 1 and more specifically paragraph 1.3.1
To be detached, compile box N°1 and deliver to automation owner together with the operation manual and maintenance schedule

CE declaration of conformity

Declaration in accordance with Directives: 2004/108/CE (EMC); 1999/5/CE (R&TTE), 2006/42/CE (MD) Appendix II, part A; 89/106/CEE (CPD) procedure according to appendix III, ii, possibility 2 (System 3)

Box N° 1

The installation of the product: M-LBAR Road Barrier matricola N° serial N° (see label):.....
 Complete with pole: XBA4 and following accessories:
 Was performed by:
 Company: Address:
 Name and Surname of responsible installer:
 The installer hereby declares to have strictly observed all provisions of the instruction manual enclosed with the product:
 Data Signature:
 Place of product installation, at: Address:

Caution! – This declaration of conformity is not to be considered valid if all fields in this box are not duly compiled.

Note - The content of this declaration corresponds to the declaration made in the official document filed in the offices of Nice S.p.a., and particularly the latest version thereof available prior to the printing of this manual. The text contained here has been adapted to meet editorial requirements. A copy of the original declaration may be requested from Nice S.p.a. (TV) I.

Declaration number: 404/M-LBAR **Revision:** 0 **Language:** EN

Name of manufacturer: NICE S.p.A.
Address: Via Pezza Alta 13, Rustignè Industrial Zone, 31046 Oderzo (TV) Italy
Person authorized to provide technical documentation: Mr. Oscar Marchetto
Product type: Electromechanical barrier lift
Model / Type: M3BAR, M5BAR, M7BAR, LBAR
Accessories: XBA14, XBA15, XBA4, XBA6, XBA18, XBA9, XBA7, XBA8

The undersigned Luigi Paro, as Managing Director, hereby declares under his own responsibility that the product identified above complies with the provisions of the following directives:

- DIRECTIVE 2004/108/EC OF THE EUROPEAN PARLIAMENT AND COUNCIL of December 15 2004 concerning alignment of Member States' legislation regarding electromagnetic compatibility and abrogating directive 89/336/EEC, according to the following harmonized standards: EN 61000-6-2:2005, EN 61000-6-3:2007
- Directive 2006/42/EC OF THE EUROPEAN PARLIAMENT AND COUNCIL of May 17 2006 regarding machines and amending directive 95/16/EC (consolidated text)
 Should the machinery be put into service in a European country with an official language different from the one of this declaration, the importer must attach the translation of this document to the declaration.
- Directive 89/106/EEC of the European Council of 21 December 1988 regarding the approximation of legislation, regulations and administration of Member States concerning construction products, according to the following harmonised standards: EN 13241-1:2003

Essential requirements for CE marking		
Characteristics	Certifying Authority	Document
Release of hazardous substances	CERT(CPD n°1600)	374/11, 375/11, 376/11, 377/11
Resistance to wind load	CERT(CPD n°1600)	374/11, 375/11, 376/11, 377/11
Safe opening for vertically moving doors	CERT(CPD n°1600)	374/11, 375/11, 376/11, 377/11
Mechanical strength and stability	–	2009_002 SP S14
Manoeuvring forces for power-operated doors/gates	CERT(CPD n°1600)	374/11, 375/11, 376/11, 377/11

(*) CERT of Treviso Tecnologia in Lancenigo di Villorba (Tv)

- Also conforms to the essential requirements specified in article 3 of the following community directive, for the products' intended use:
- Directive 1999/5/CE OF THE EUROPEAN PARLIAMENT AND COUNCIL dated March 9 1999 regarding radios and communications terminals and reciprocal recognition of their conformity in accordance with the following harmonized standards:
 - Protection of health (art. 3(1)(a)): EN 50371:2002
 - Electrical safety (art. 3(1)(a)): EN 60950-1:2006+A11:2009
 - Electromagnetic compatibility (art. 3(1)(b)): EN 301 489-1 V1.8.1:2008, EN 301 489-3 V1.4.1:2002
 - Radio spectrum (art. 3(2)): EN 300 330-2 V1.5.1:2010

In accordance with directive 1999/5/CE (annex V), the product is classified as class 1 and marked: **CE 0682**

The product also complies with the following standards:
 EN 60335-1:2002 + A1:2004 + A11:2004 + A12:2006 + A2:2006 + A13:2008+A14:2010
 The parts of the product which are subject to the following standards comply with them:
 EN 13241-1:2003, EN 12445:2002, EN 12453:2002, EN 12978:2003, EN 60335-2-103:2003+A11:2009

Oderzo, June 21 2011

Luigi Paro
(Managing Director)

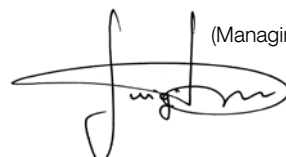

APPENDIX II

Declaration of conformity to be used in case the product is not installed in compliance with the criteria reported in chapter 1.3.1.

CE declaration of conformity and declaration of incorporation for a “quasi-machine”

**Declaration in accordance with Directives: 1995/5/EC (R&TTE), 2004/108/EC (EMC);
2006/42/EC (MD) annex II, part B**

Note - The content of this declaration corresponds to the declaration made in the official document filed in the offices of Nice S.p.a., and particularly the latest version thereof available prior to the printing of this manual. The text contained here has been adapted to meet editorial requirements. A copy of the original declaration may be requested from Nice S.p.a. (TV) I.

Declaration number: 402/M-LBAR

Revision: 0

Language: EN

Name of manufacturer: NICE S.p.A.

Address: Via Pezza Alta 13, Rustignè Industrial Zone, 31046 Oderzo (TV) Italy

Person authorized to provide technical documentation: Mr. Oscar Marchetto

Product type: Electromechanical barrier lift

Model / Type : M3BAR, M5BAR, M7BAR, LBAR

Accessories: XBA14, XBA15, XBA4, XBA6, XBA18, XBA9, XBA7, XBA8

The undersigned Luigi Paro, as Managing Director, hereby declares under his own responsibility that the products identified above comply with the provisions of the following directives:

- Directive 1999/5/CE OF THE EUROPEAN PARLIAMENT AND COUNCIL dated March 9 1999 regarding radios and communications terminals and reciprocal recognition of their conformity in accordance with the following harmonized standards:
 - Protection of health (art. 3(1)(a)): EN 50371:2002
 - Electrical safety (art. 3(1)(a)): EN 60950-1:2006+A11:2009
 - Electromagnetic compatibility (art. 3(1)(b)): EN 301 489-1 V1.8.1:2008, EN 301 489-3 V1.4.1:2002
 - Radio spectrum (art. 3(2):)): EN 300 330-2 V1.5.1:2010

In accordance with directive 1999/5/CE (annex V), the product is classified as class 1 and marked: **CE 0682**

- DIRECTIVE 2004/108/EC OF THE EUROPEAN PARLIAMENT AND COUNCIL of December 15 2004 concerning alignment of Member States' legislation regarding electromagnetic compatibility and abrogating directive 89/336/EEC, according to the following harmonized standards: EN 61000-6-2:2005, EN 61000-6-3:2007

The product also complies with the following directive in accordance with the requirements for “quasi-machines”:

- Directive 2006/42/EC OF THE EUROPEAN PARLIAMENT AND COUNCIL of May 17 2006 regarding machines and amending directive 95/16/EC (consolidated text)
 - I declare that the pertinent technical documentation has been prepared in accordance with Annex VII B to Directive 2006/42/EC and that the following essential requirements have been met: 1.1.1- 1.1.2- 1.1.3- 1.2.1-1.2.6- 1.5.1-1.5.2- 1.5.5- 1.5.6- 1.5.7- 1.5.8- 1.5.10- 1.5.11
 - The manufacturer agrees to send the national authorities pertinent information on the “quasi-machine” in response to a motivated request without affecting its intellectual property rights.
 - If the “quasi-machine” is operated in a European country with an official language other than the language used in this declaration, the importer must associate a translation with this declaration.
 - The “quasi-machine” must not be operated until the final machine in which it is to be incorporated is declared to conform to the provisions of Directive 2006/42/EC, if applicable to it.

The product also complies with the following standards:

EN 60335-1:2002 + A1:2004 + A11:2004 + A12:2006 + A2:2006 + A13:2008+A14:2010

The parts of the product which are subject to the following standards comply with them:

EN 13241-1:2003, EN 12445:2002, EN 12453:2002, EN 12978:2003, EN 60335-2-103:2003+A11:2009

Oderzo, June 21 2011

Luigi Paro

(Managing Director)

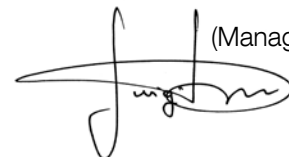

Operation manual

(to be given to the final user of MBAR and LBAR)

Before using the automation for the first time, ask the installer to explain the origin of residual risks and devote a few minutes to reading this user instruction and warning manual given to you by the installer. Keep the manual for reference when in doubt and pass it on to new owners of the automation.

IMPORTANT! – Your automation is a machine that performs your commands faithfully; negligent or improper use may constitute a hazard:

- Never activate automation controls if persons, animals or objects are present in the operating range.
- Never touch parts of the automation while the pole is moving!
- Transit is only permitted if the pole is completely open and stationary!

Warnings

1 - Children: An automation system guarantees a high level of safety, using its detection systems to prevent movement in the presence of persons or objects, and ensuring constantly foreseeable and safe activation. Nonetheless, it is advisable to ensure that children do not play in the vicinity of the automation. This is not a toy!

2 - This product is not designed to be used by persons (including children) whose physical, sensorial or mental capacities are reduced, or with lack of experience or skill, unless suitable instructions regarding use of the product have been provided by a person responsible for safety or under supervision of the latter.

3 - Malfunctions: if the automation is seen to perform abnormally, disconnect the electrical power supply from the system and manually release the gearmotor. Never attempt to perform repairs; contact your local installer for assistance. In the meantime the system can be used as a manual access point, after releasing the gearmotor as described below in this document. **In the event of breakage or a power failure**, while waiting for the installer or the electrical power supply to return, if the buffer battery is not fitted, the automation can still be used. Manually release the gearmotor (see step 9 - Gearmotor manual releasing and locking) and move the pole manually as required.

4 - Safety devices disabled: the barrier can be operated even when the safety device on the barrier does not work correctly:

- Activate the barrier command (with the transmitter or key-operated selector switch, etc.); if all is in working order, the pole opens or closes normally; otherwise the flashing light emits a number of flashes and the manoeuvre is not started (the number of flashes depends on the reason for which the manoeuvre does not start).
- In this case, the user must press and hold the command within three seconds.
- After approx. 2 seconds the barrier will start to operate in “hold-to-run” mode, i.e. the pole will continue to move while the command is activated; **THE POLE STOPS AS SOON AS THE COMMAND IS RELEASED.**

If the safety devices are out of service, the automation must be repaired as soon as possible.

5 - Even if you possess the skills, never modify the system or programming and setting parameters of the automation: this is the responsibility of the installer.

6 - Testing, periodic maintenance and any repairs must be documented by the person performing the operations and the relevant documents must be kept by the system owner. The only operations that can be performed by the user periodically are to clean the photocell lenses and the automation. To prevent anyone from activating the barrier, release the automation system before proceeding with the operations (as described below). Use a slightly damp cloth to clean.

7 - Disposal: At the end of the automation’s lifetime, ensure that it is disposed by qualified personnel and that the materials are recycled or scrapped according to current local standards.

8 - Gearmotor manual release and locking: The gearmotor is equipped with a mechanical system that enables manual opening and

closing of the pole. These operations are required in the event of a power failure or malfunctions.

IMPORTANT! – The gearmotor release and locking operations must be performed only when the pole is horizontal and stationary.

To manually lock and release the barrier, insert the key supplied and turn it by 180° (**fig. A**); the key can be turned to the left or to the right.

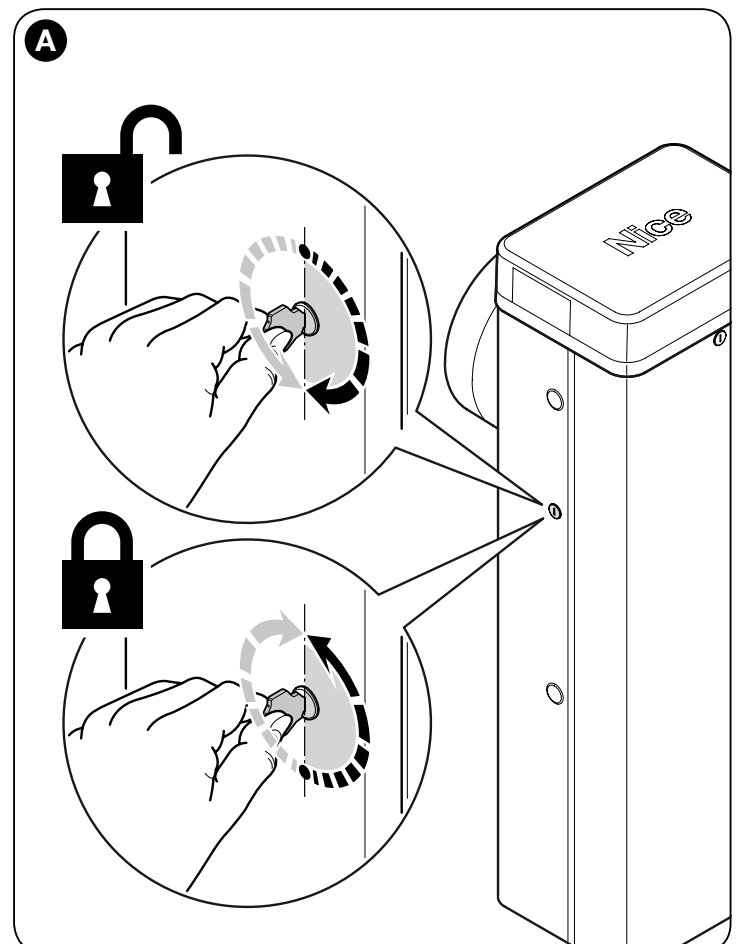

Maintenance schedule

(to be given to the final user of MBAR and LBAR)

MAINTENANCE REGISTER

Important – This register must be given to the automation owner after compilation of all required parts.

This register must list all maintenance operations, repairs and modifications performed. The Register must be updated on each operation and stored in a safe place for future inspections by authorised organisations.

This Maintenance Register refers to the following automation:

mod. MBAR and LBAR - serial n° - date of installation - at

The following enclosed documents are part of the Register:

- 1) - Maintenance schedule
- 2) -
- 3) -
- 4) -
- 5) -
- 6) -

According to the enclosed document "Maintenance Schedule", maintenance operations must be performed at the following intervals: **every 6 months** or **50,000 manoeuvre cycles**, depending on which event occurs first.

MAINTENANCE SCHEDULE

Important! – System maintenance must be performed by technical and qualified personnel, in strict observance of safety standards as envisaged by current legislation and the safety precautions stated in Chapter 1 - "General safety warnings and precautions", at the start of this manual.

In general, the road barrier does not require special maintenance; however, regular checks over time will guarantee system efficiency and ensure correct operation of the safety systems installed.

If the road barrier is equipped with other devices not mentioned in this manual, follow the instructions in the relative maintenance schedules. Considering normal domestic use of the automation, periodic checks of the system are recommended: every 6 months or 50,000 manoeuvres.

Note also that in the event of spring breakage, the road barrier still remains compliant with the requirement in 4.3.4 of the standard EN 12604: 2000.

- The pole balancing system must be checked at least twice a year, preferably when the season changes.

At the envisaged interval, the following checks and replacements must be made for maintenance.

- 1 Disconnect any electrical power source.
- 2 Check the state of deterioration of all the materials of the barrier, paying special attention to cases of corrosion or oxidation of the structural parts; replace the parts that do not provide sufficient guarantee.
- 3 Check that the screw connections are adequately tightened (especially those of the balancing screw)
- 4 Check the absence of clearance between the balancing lever and the output shaft. If this is the case, tighten the central screw down.
- 5 Lubricate the rod end of the balancing screw and the lower bolt.
- 6 In the M7BAR and LBAR versions, check the perfect locking between the two pole segments. Use the expansion screws if necessary.
- 7 Position the pole in the vertical position and make sure that the pitch between the loops of the balancing screw is constant without deformations.
- 8 Release and check the correct balancing of the pole and any obstacle during manual opening and closing.
- 9 Release again and carry out the test procedure.
- 10 **Check protection against the risk of lifting:** on automations with vertical movement, it must be ensured that there is no risk of lifting. This test can be performed as follows: hang a weight of 20 kg mid-way along the pole (for example, a sack of gravel), activate an Opening manoeuvre and ensure that during operation the pole does not exceed the height of 50 cm from the closing position. If the pole exceeds this height, reduce the motor force (see chapter 6 - Table 7).

11 If hazardous situations generated by the moving poles are protected by means of impact force limitation, measure the force as specified in the standard EN 12445. If motor force control is used as auxiliary function with the system for reduction of impact force, test and identify the setting that obtains the best results.

12 Check efficiency of the release system: place the pole in the Closing position and manually release the gearmotor (see paragraph 3.6) ensuring that there is no difficulty with this procedure. Ensure that the manual force required to move the pole on opening is no greater than 200 N (approx. 20 Kg); the force is measured perpendicular to the pole and at 1 m from the rotation axis. Lastly, ensure that the key required for manual release is available in the vicinity of the automation.

13 Power supply disconnection system check: by using the power disconnect device, and disconnecting any buffer batteries, ensure that all leds on the control unit are off and that the rod remains stationary when any commands are sent. Check efficiency of the locking device to prevent inadvertent and/or unauthorised connection.

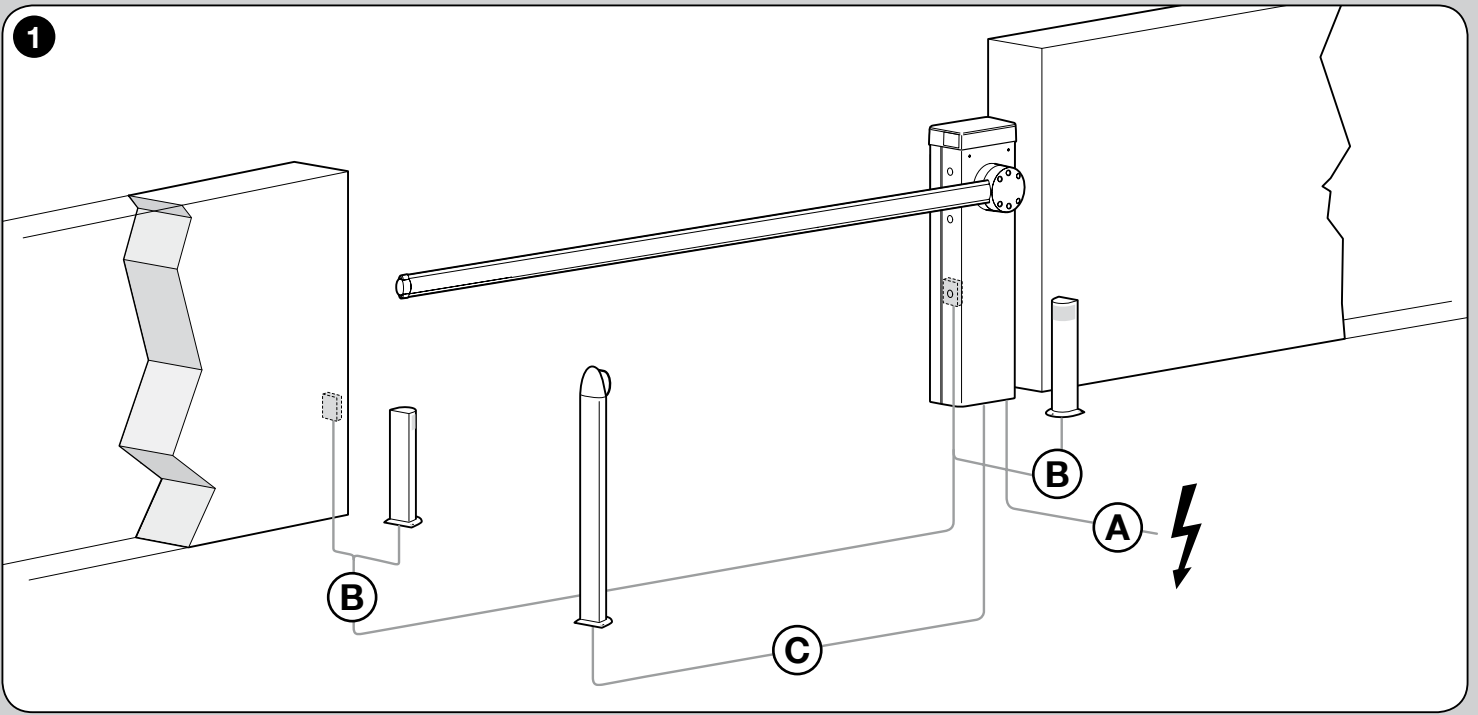
1**2****M3BAR - M5BAR - M7BAR**

- EN - with joint • IT - con giunto • FR - avec raccord • ES - con unión
- DE - mit Gelenkverbindung • PL - ze złączką • NL - met verbindingsstuk

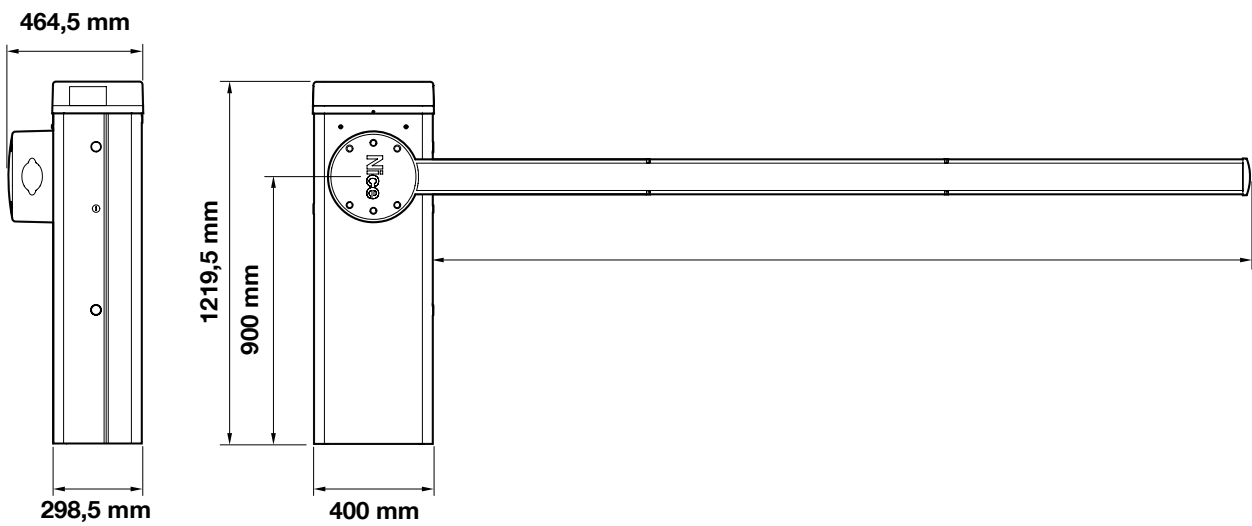
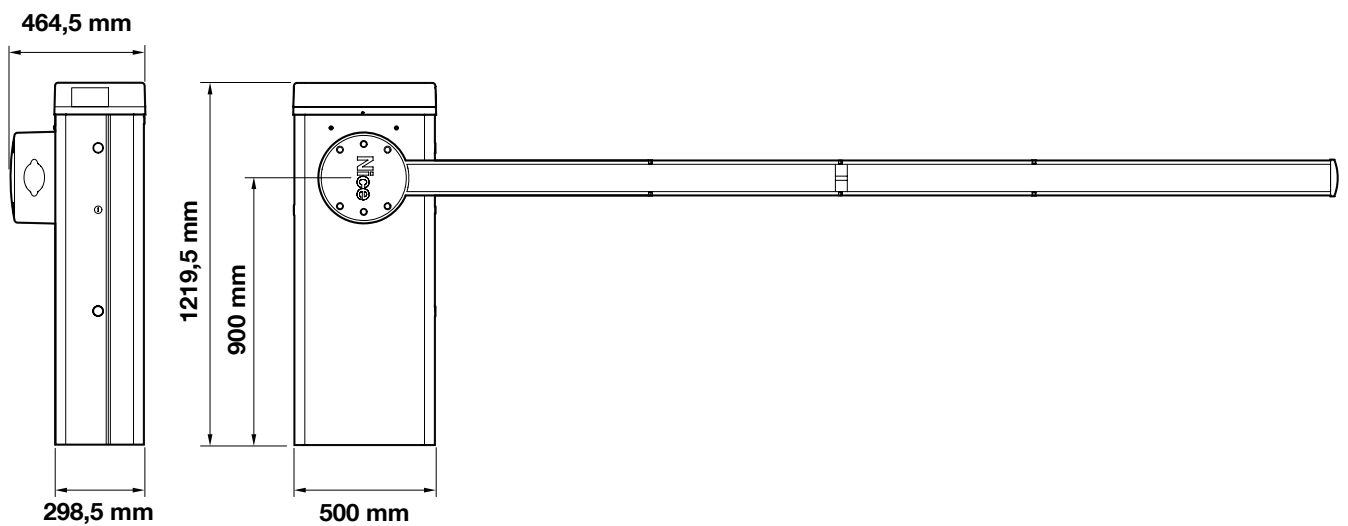
**LBAR**

3

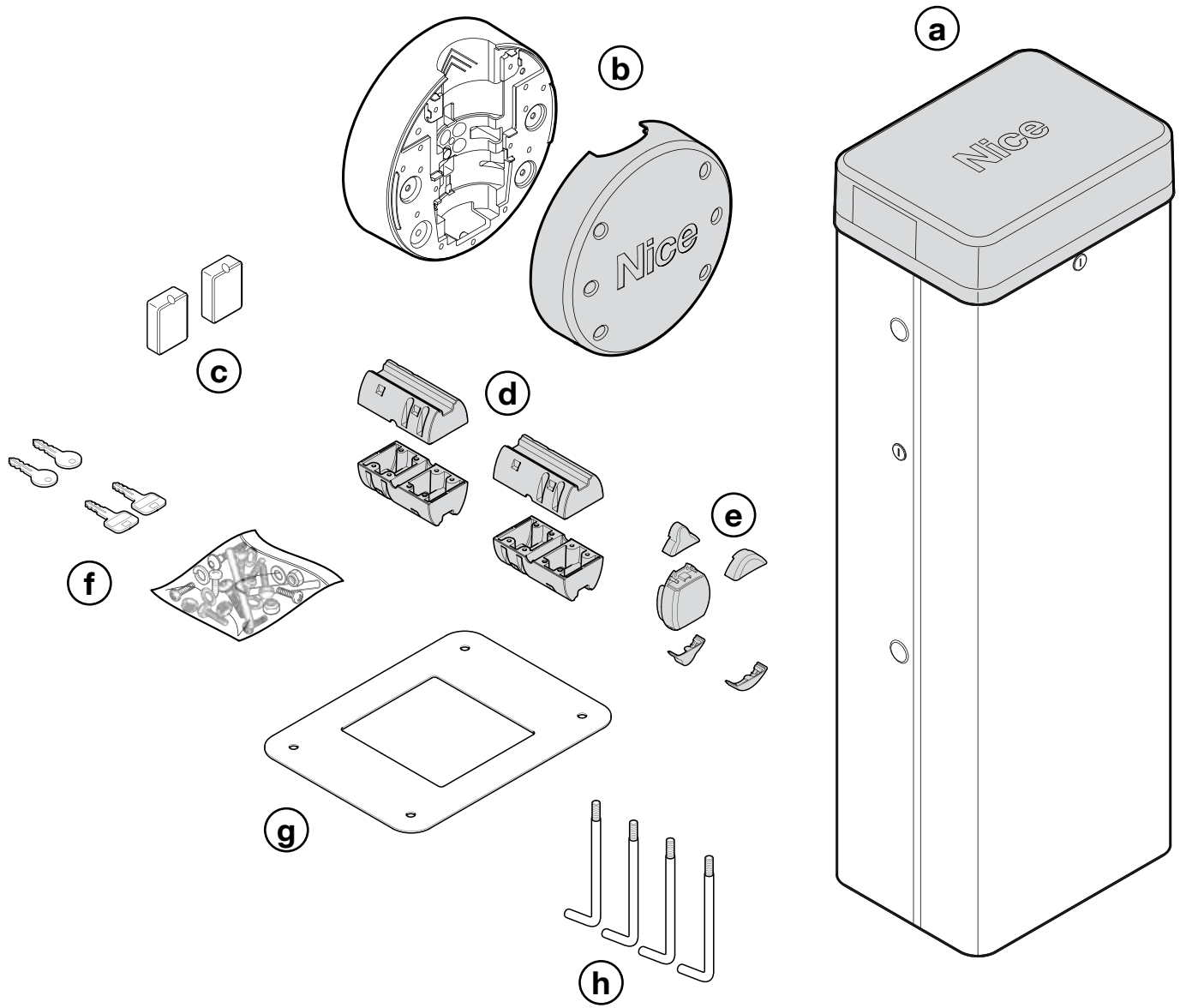

4

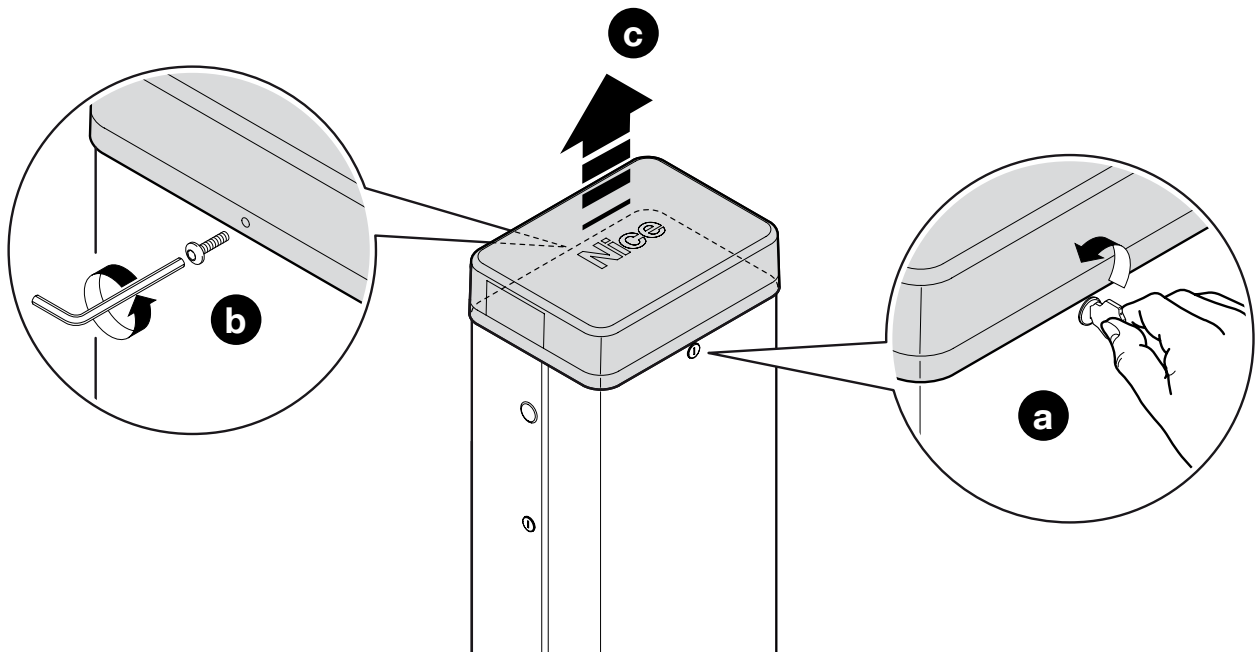

5

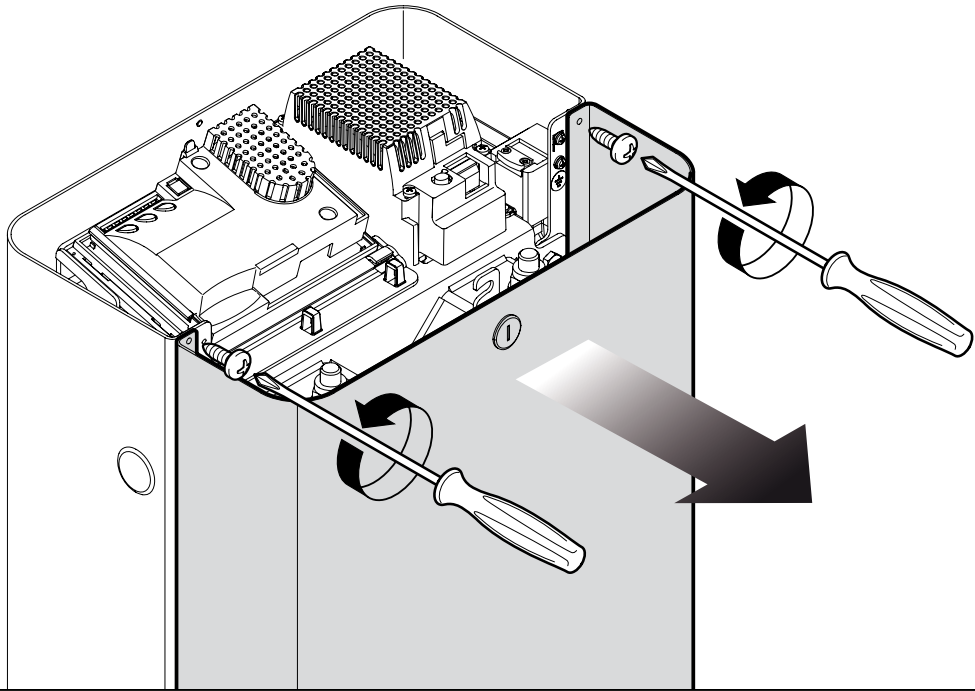

6

M3BAR - M5BAR - M7BAR

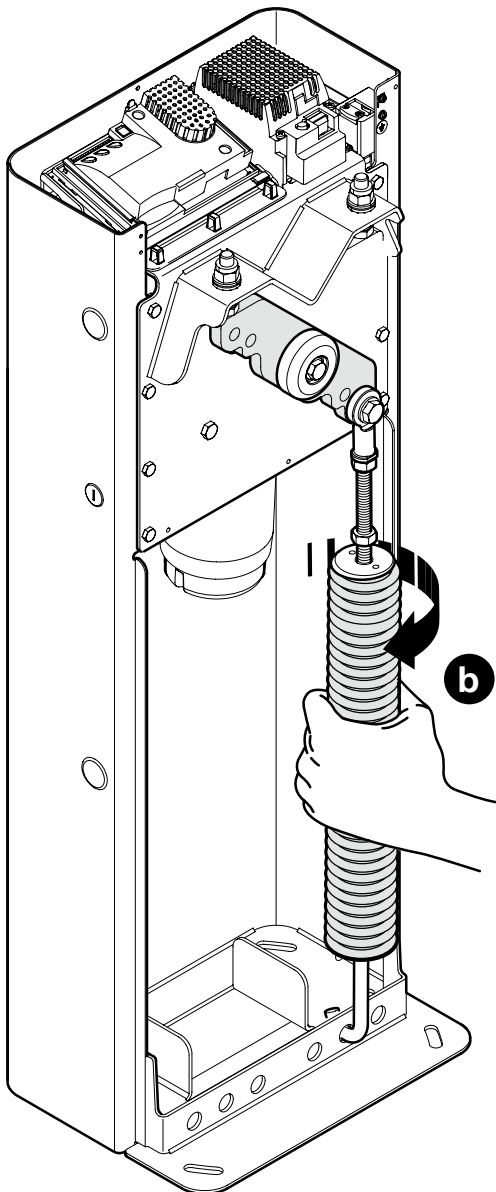

a

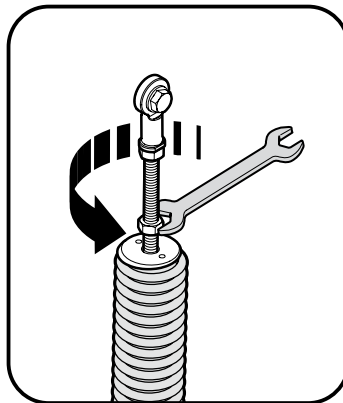

d

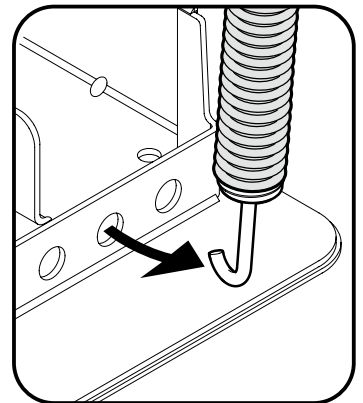

c

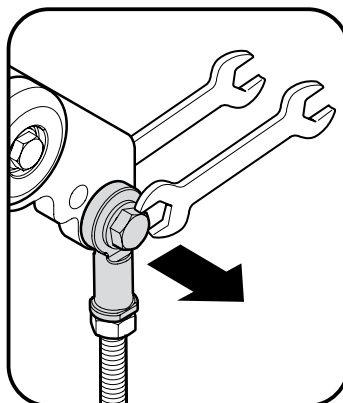

d (M7BAR)

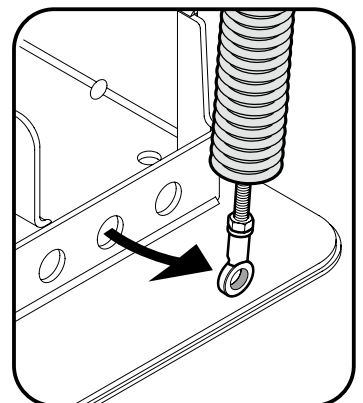

7

LBAR

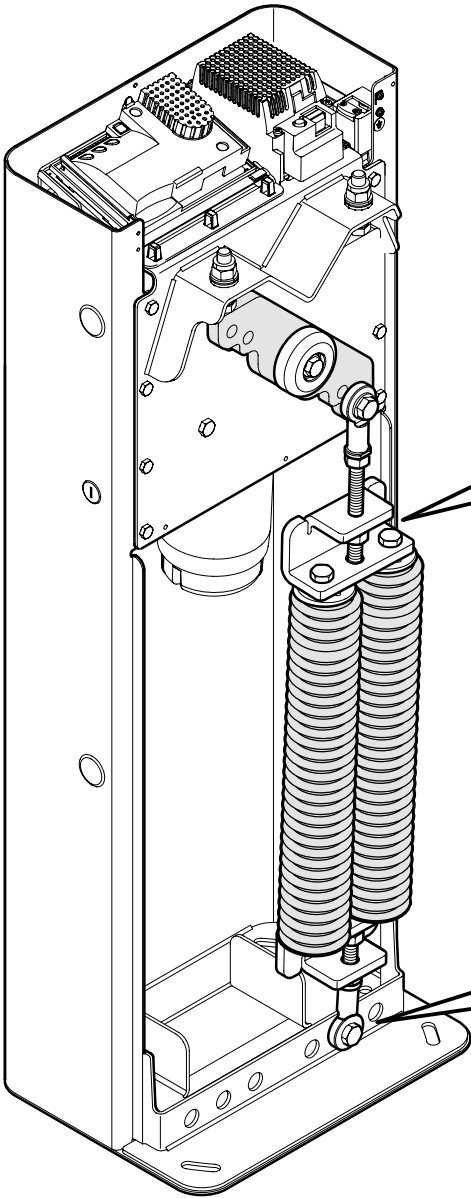

a

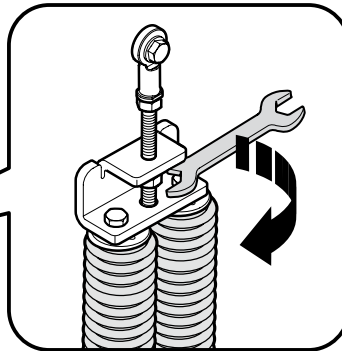

b

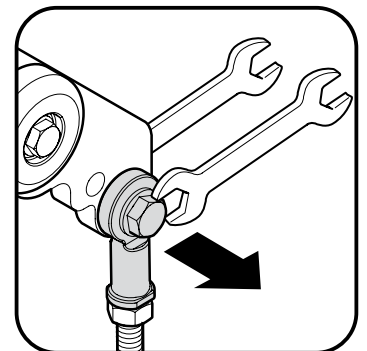

c

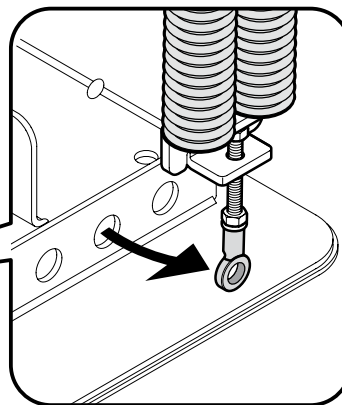

8

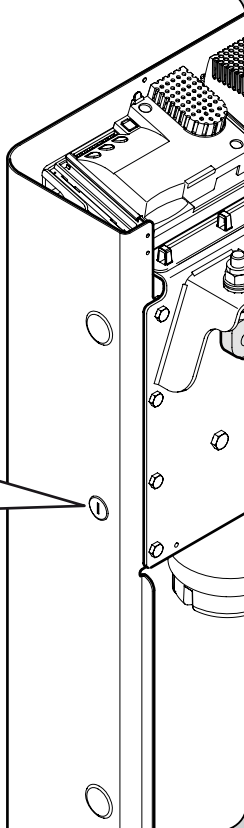

9

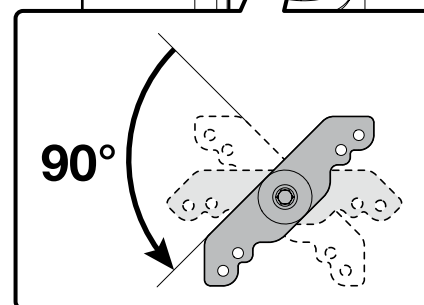
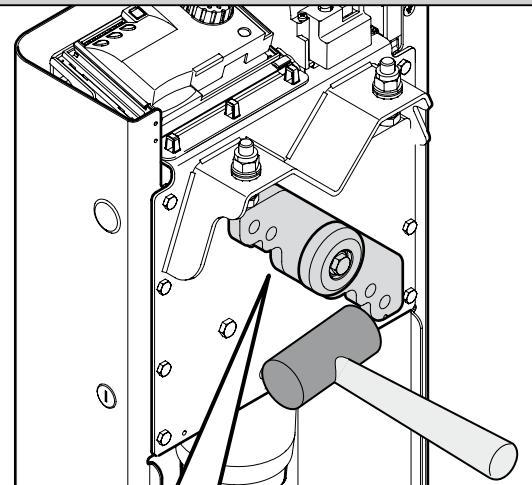

10

M3BAR - M5BAR

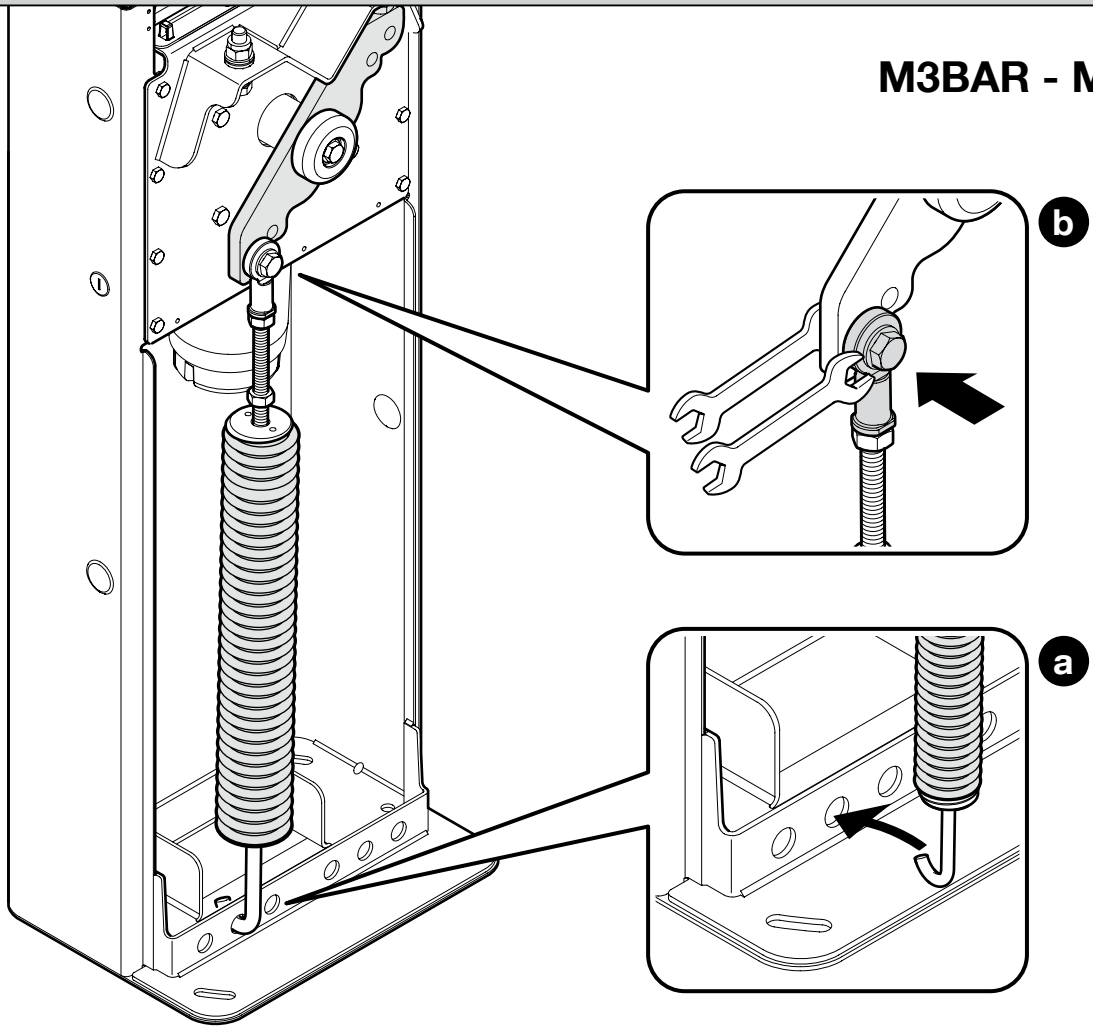

11

LBAR

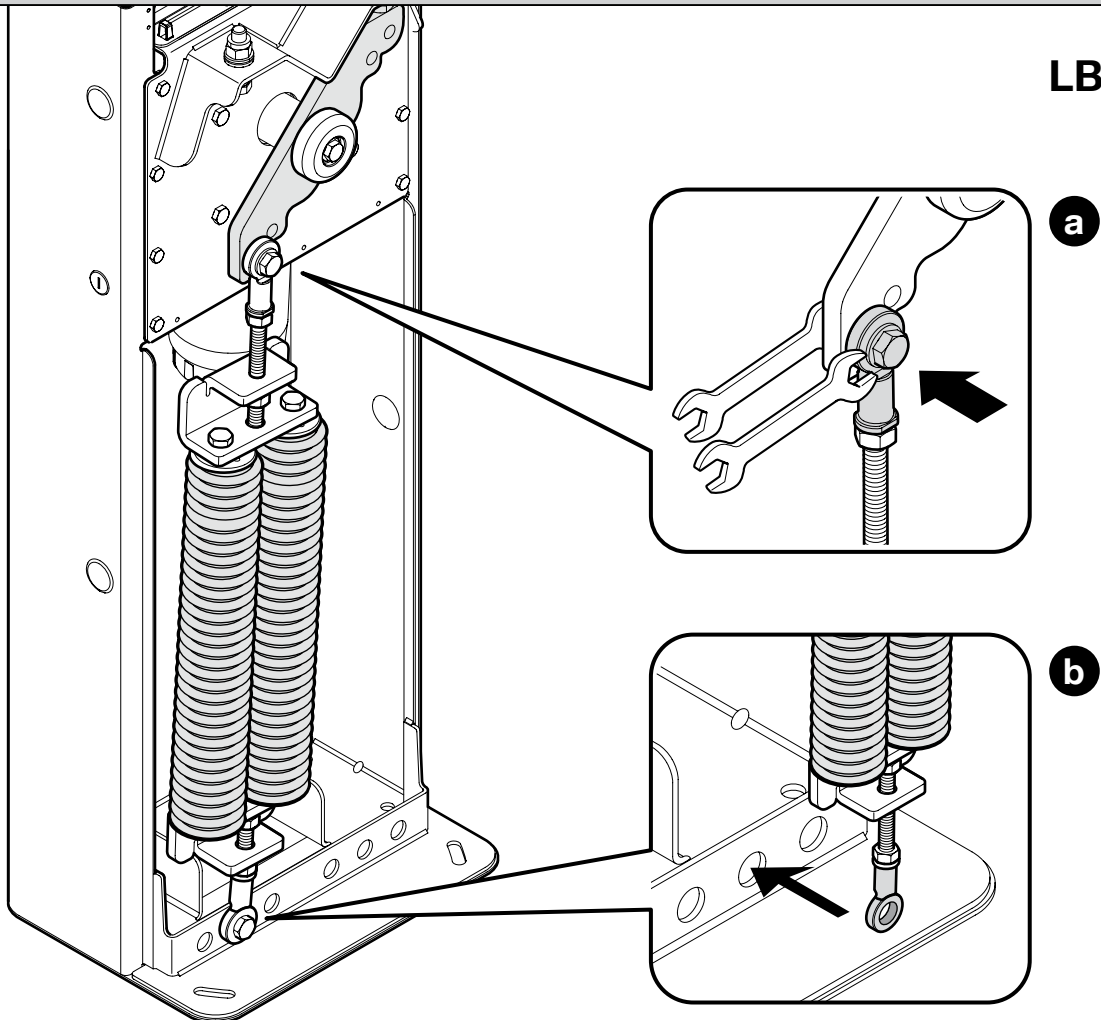

12

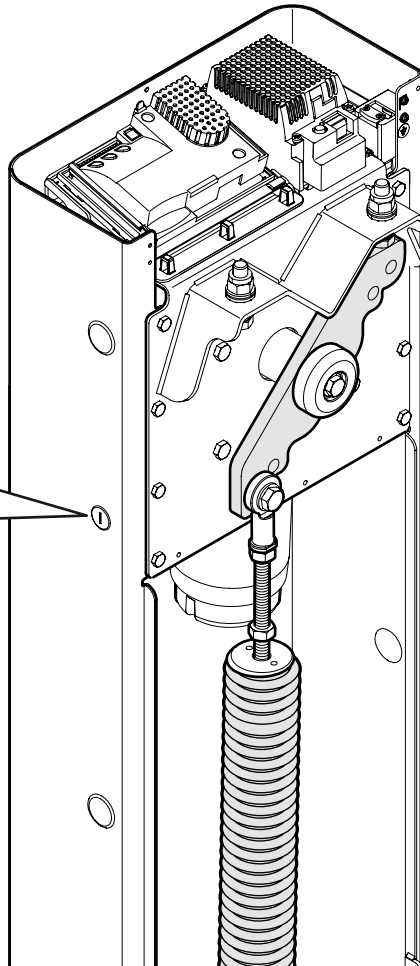
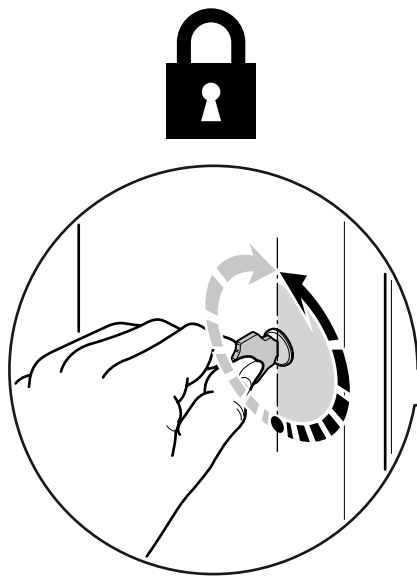

13

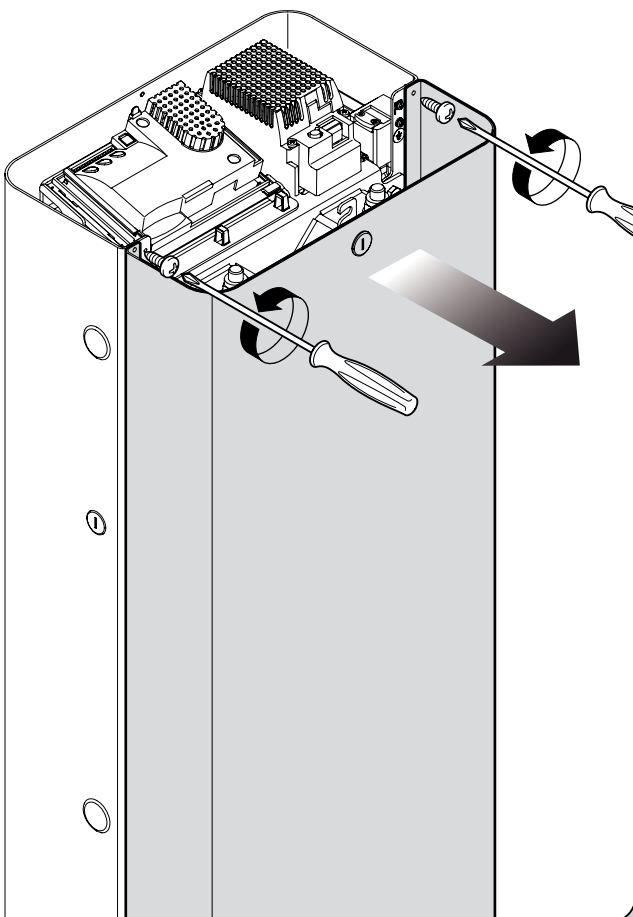

14

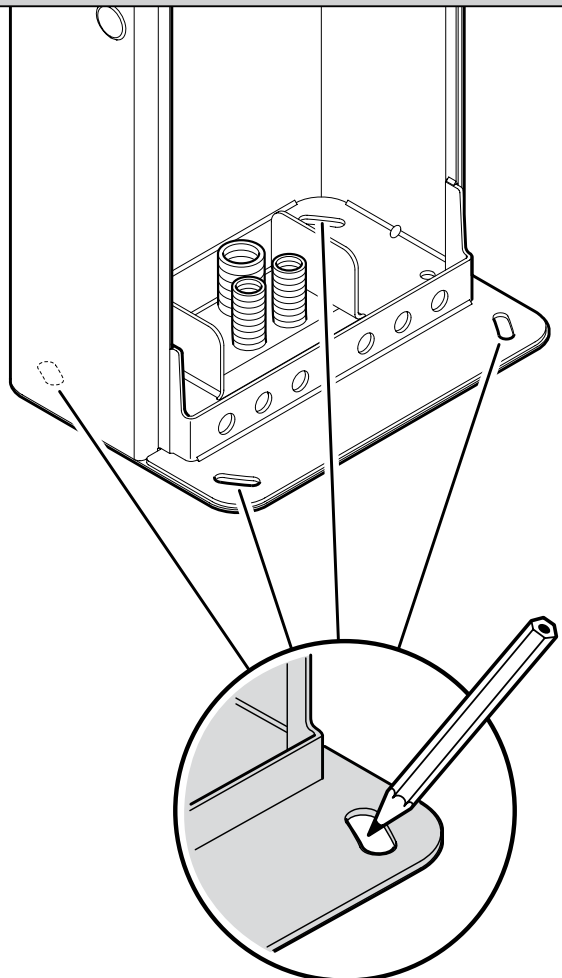

15

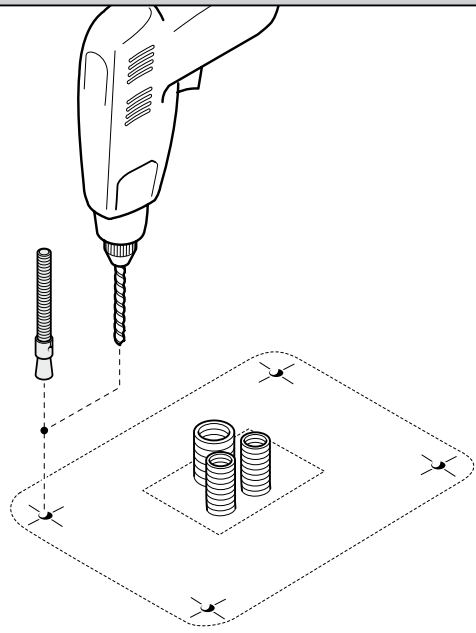
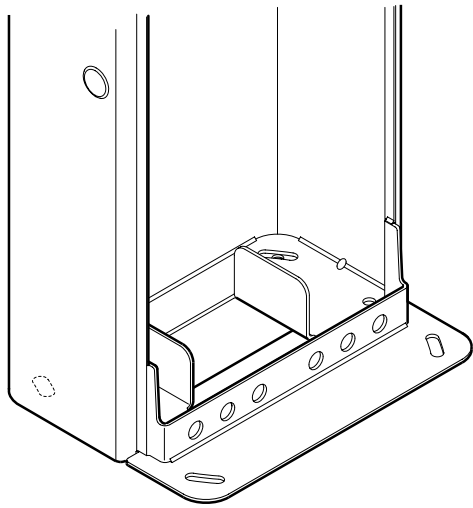

16

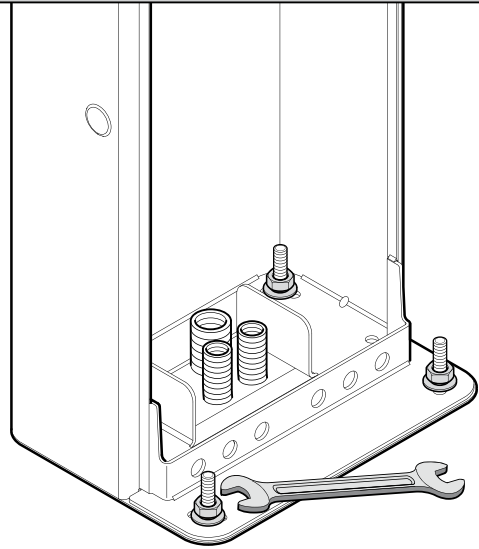
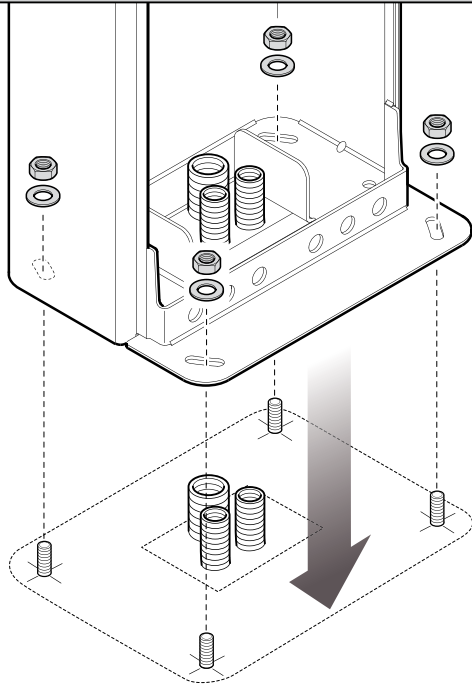

17

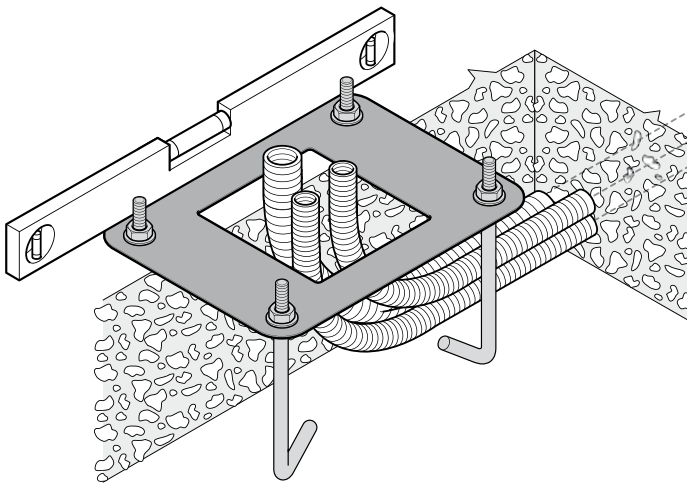

18

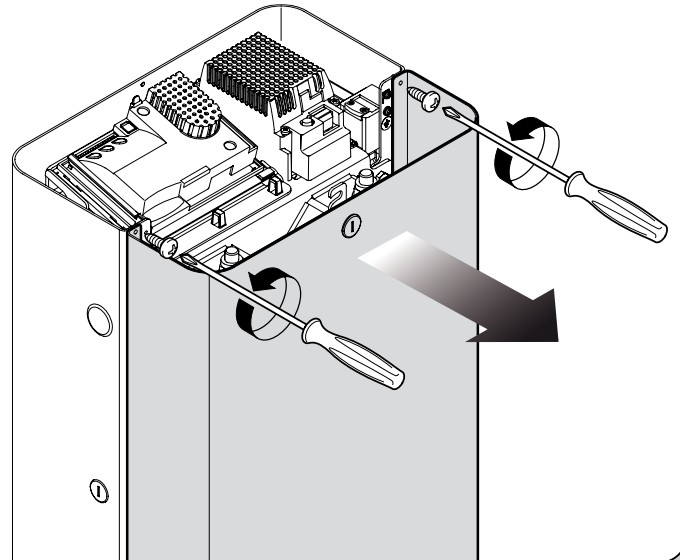

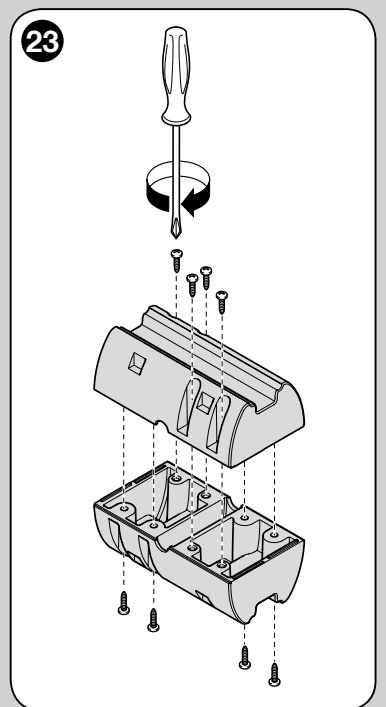
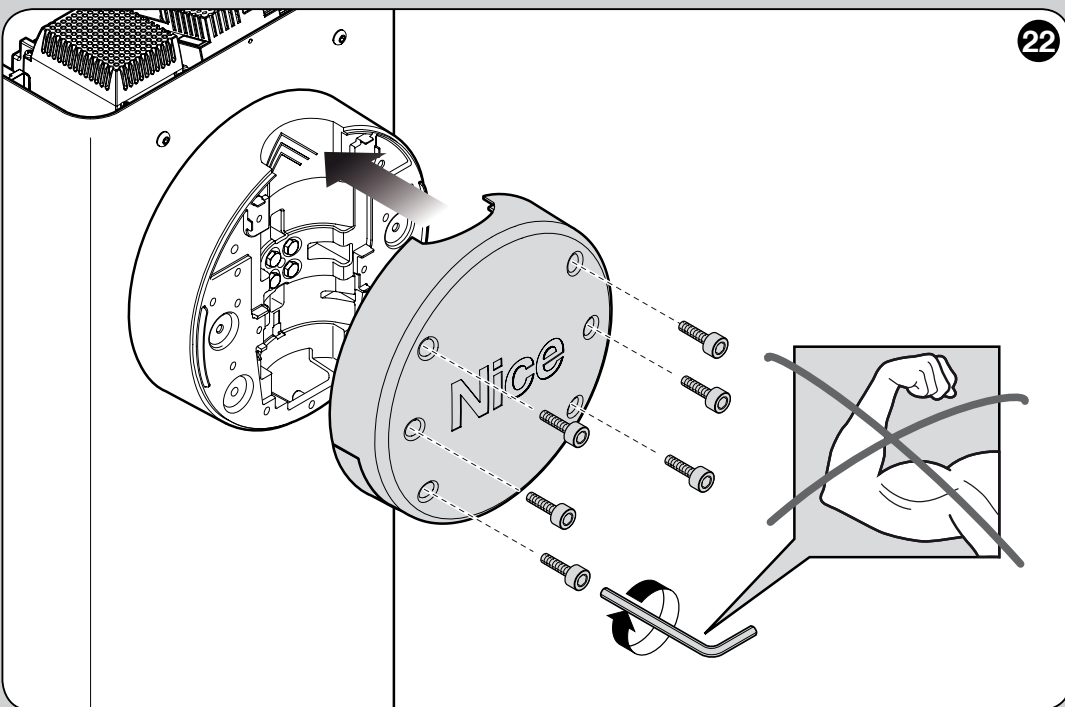
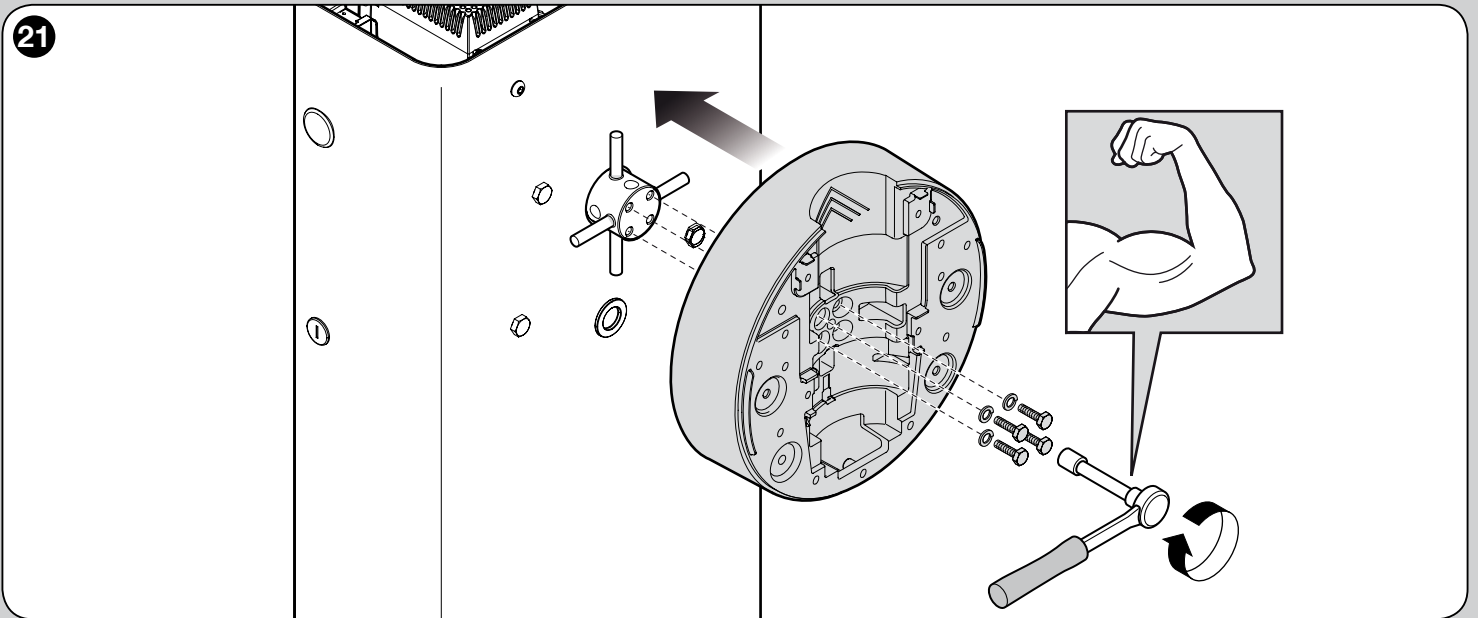
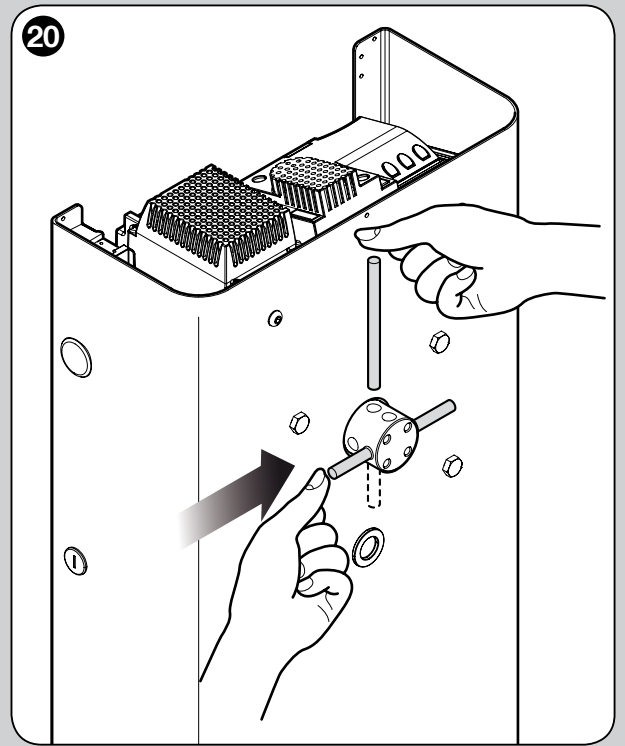
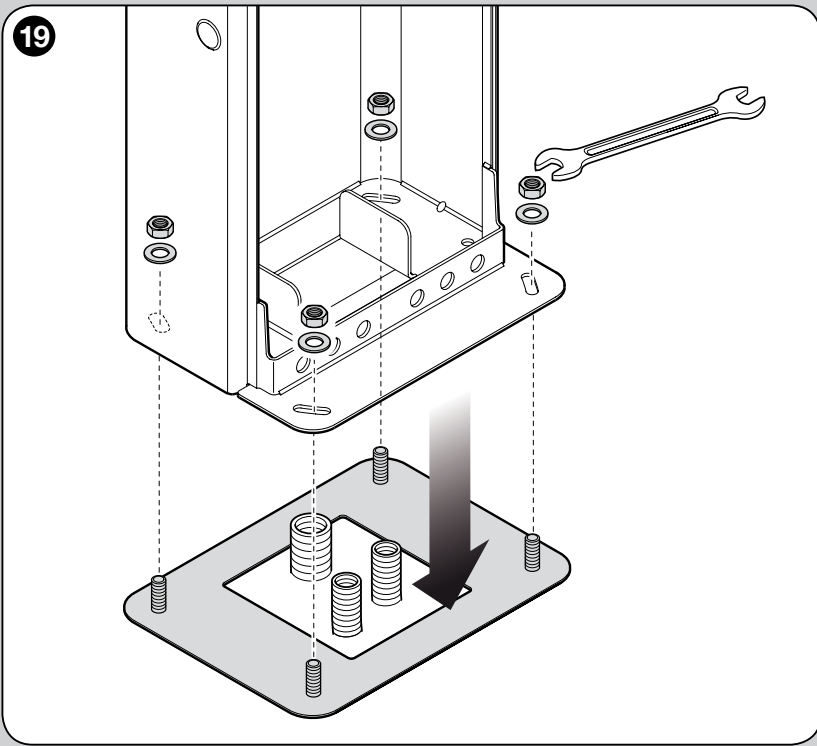

24

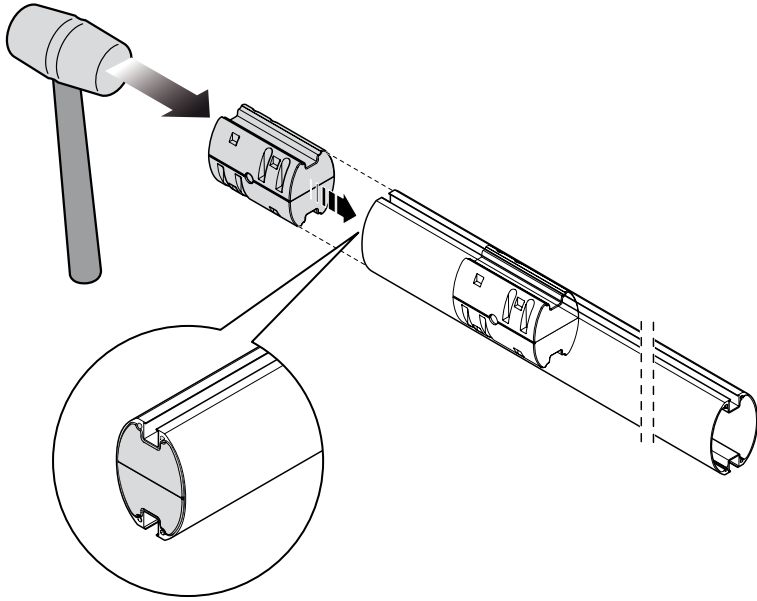

25

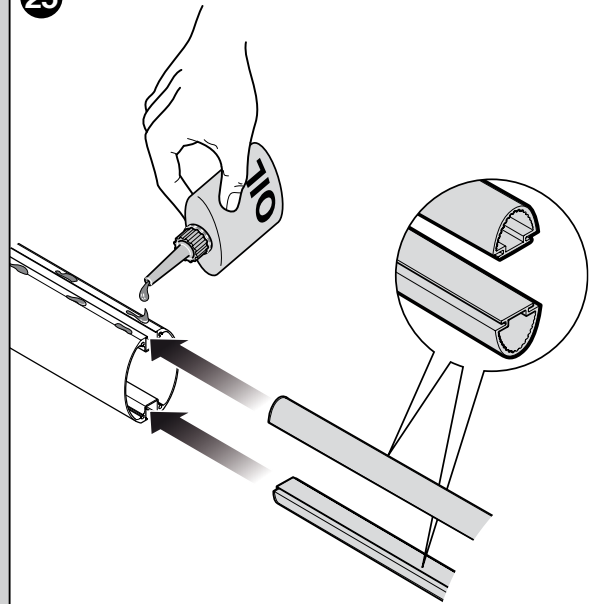

26

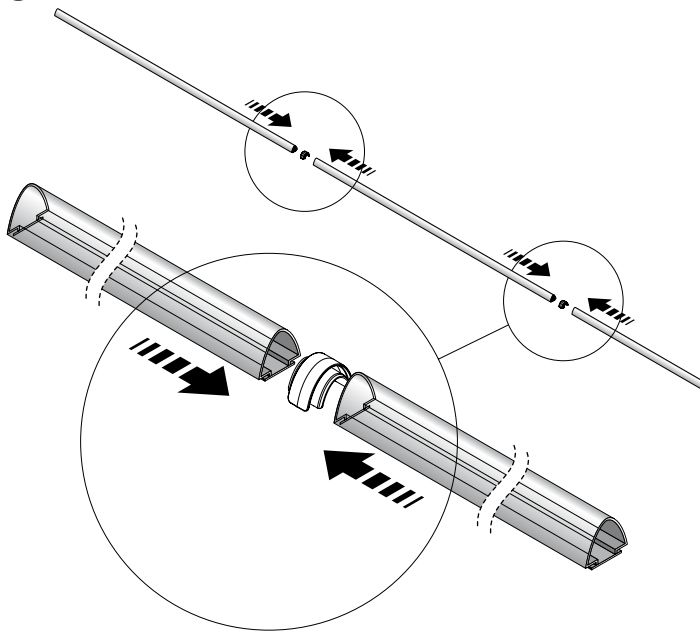

27

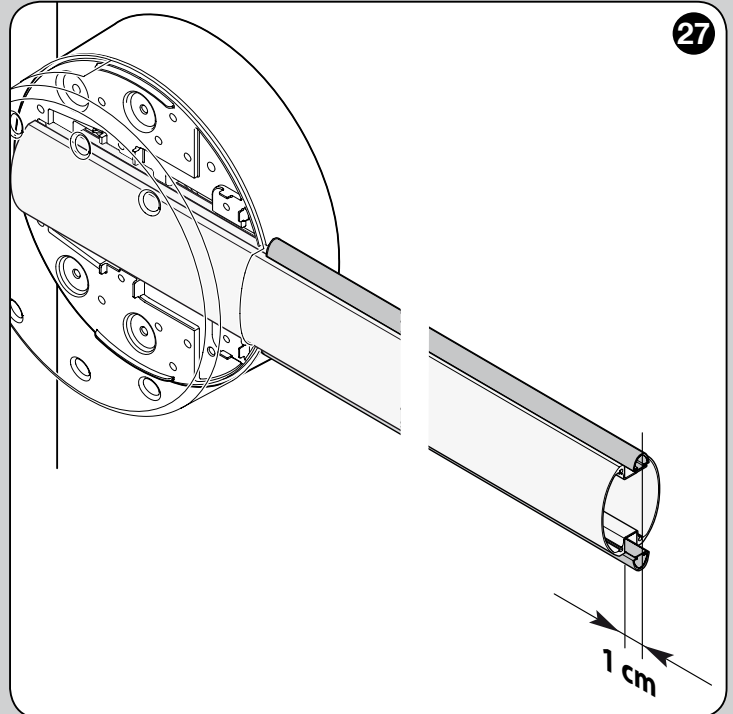

28

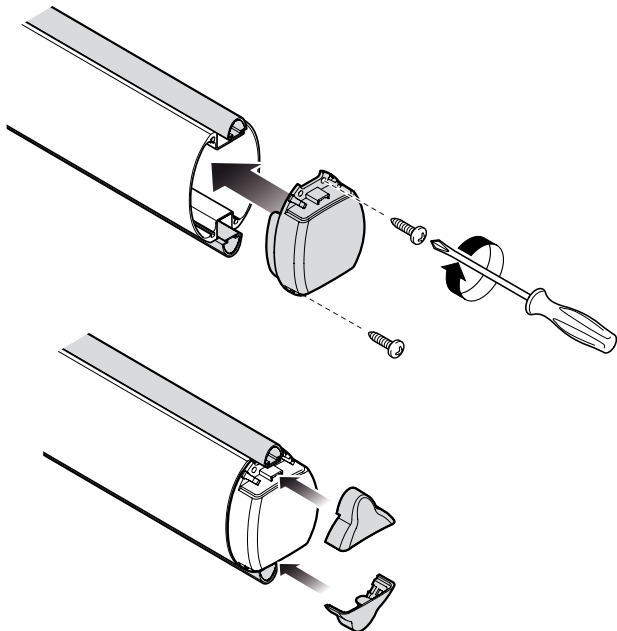

29

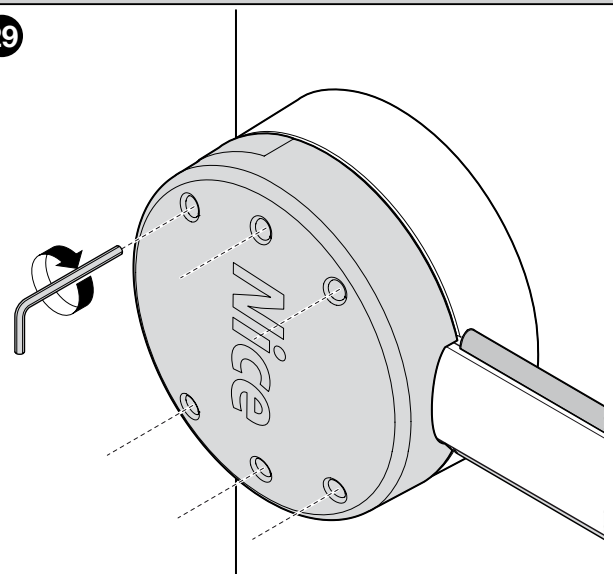

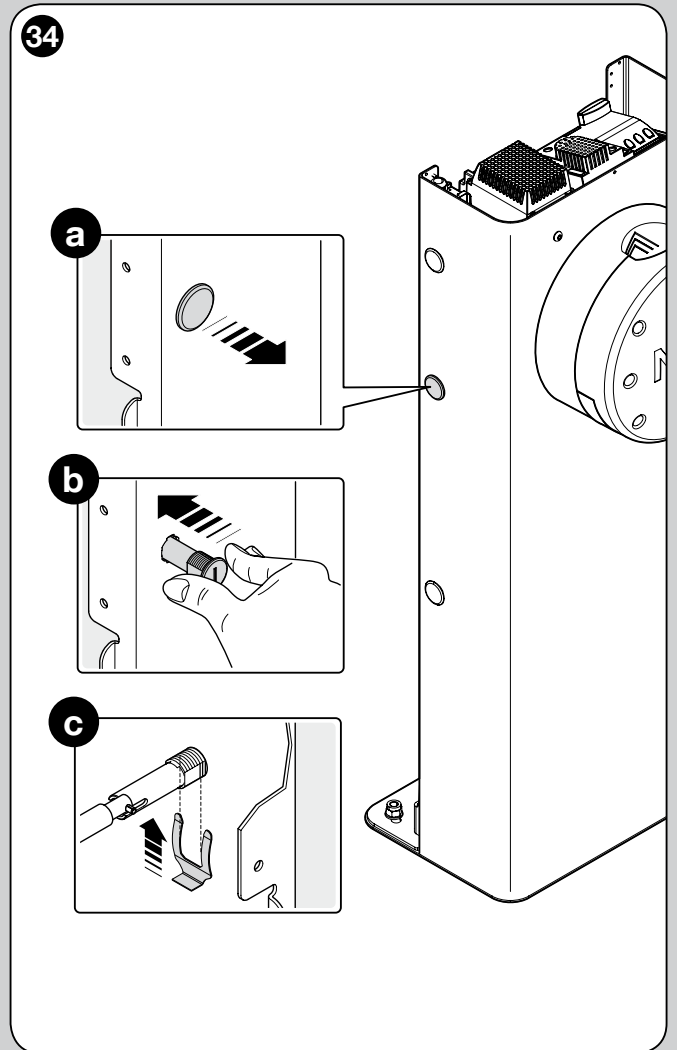
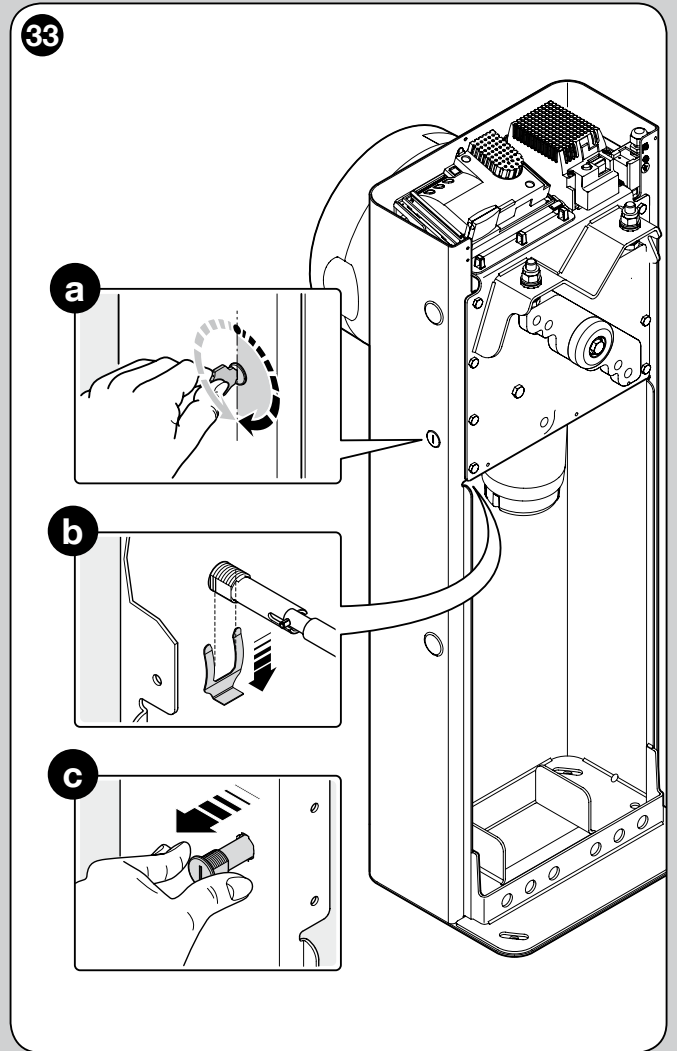
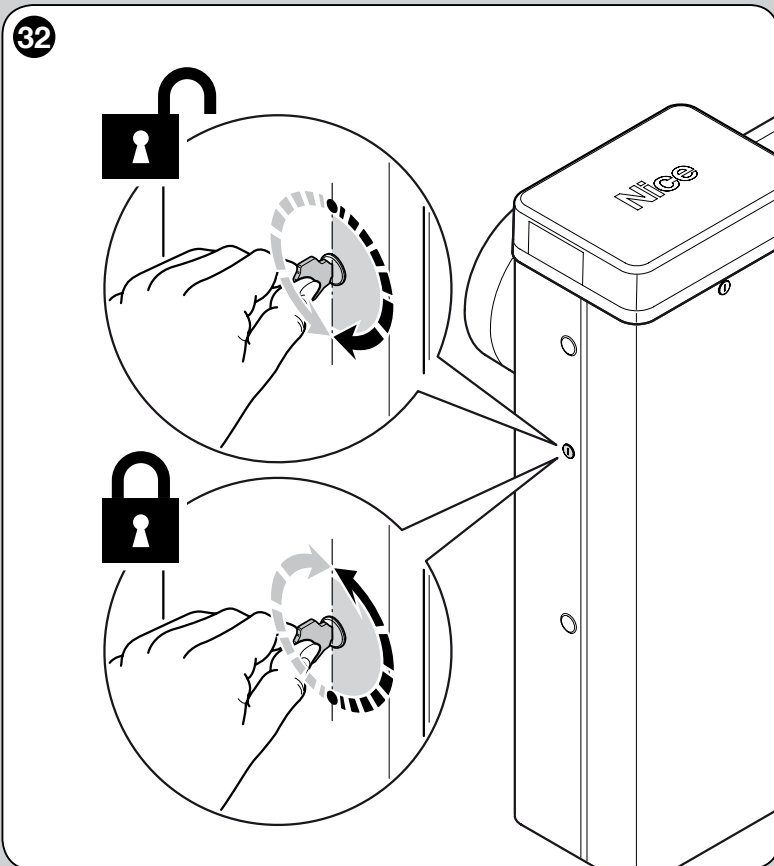
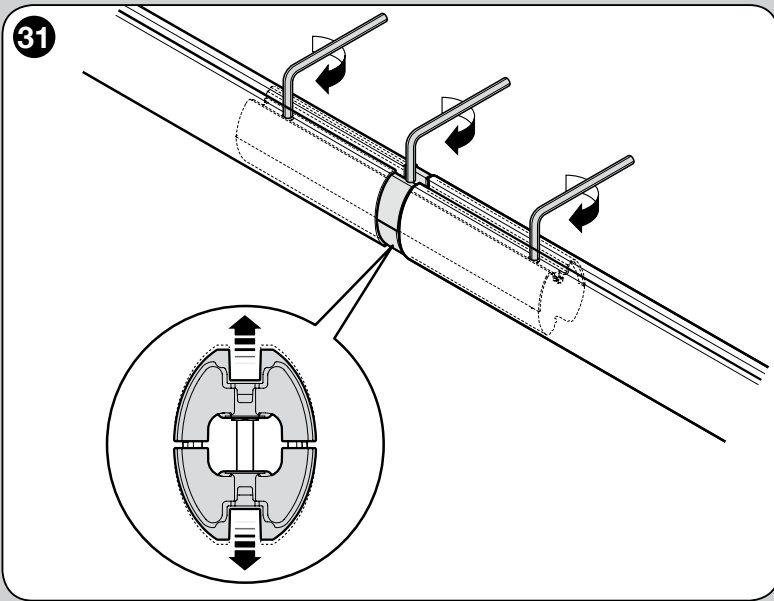
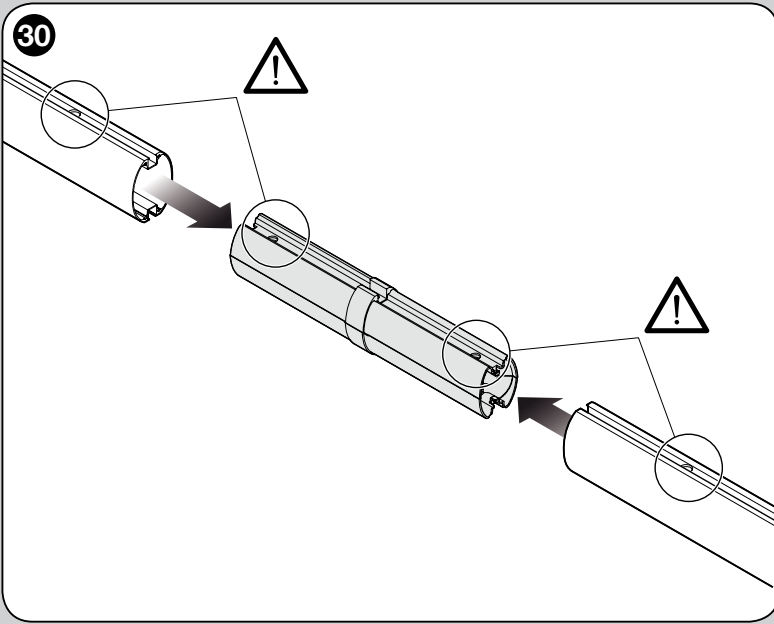

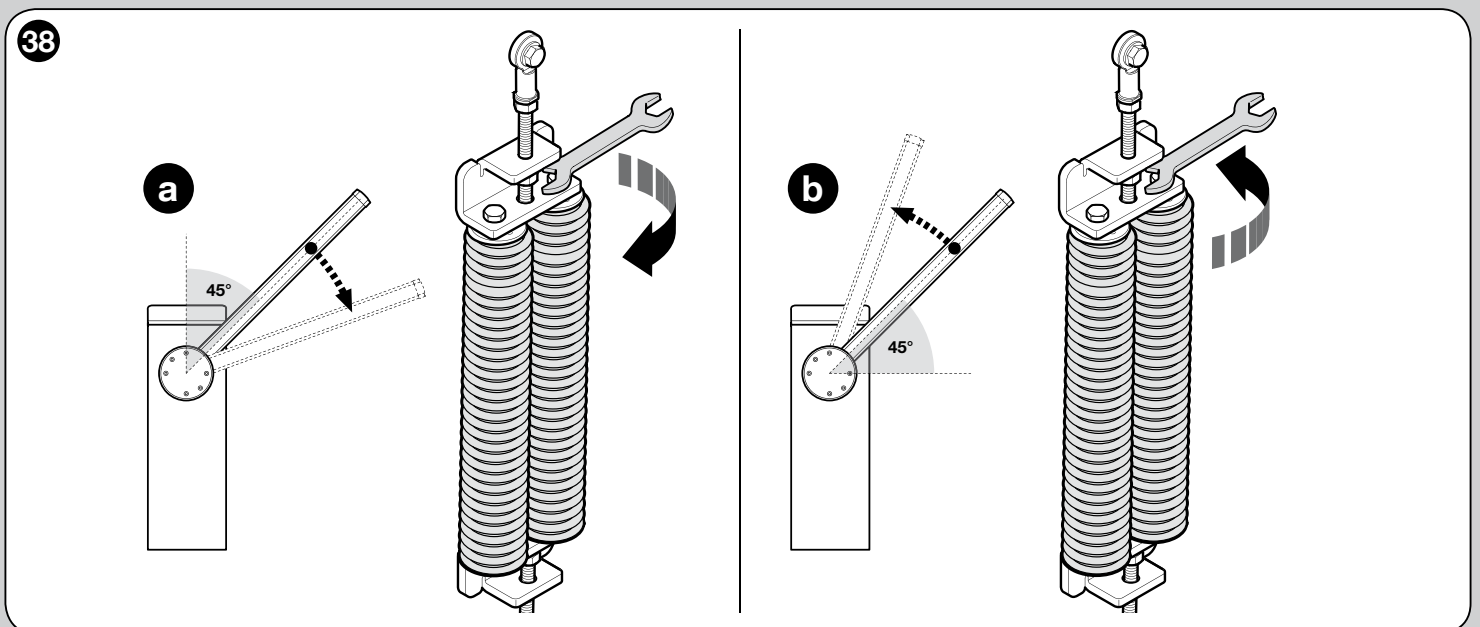
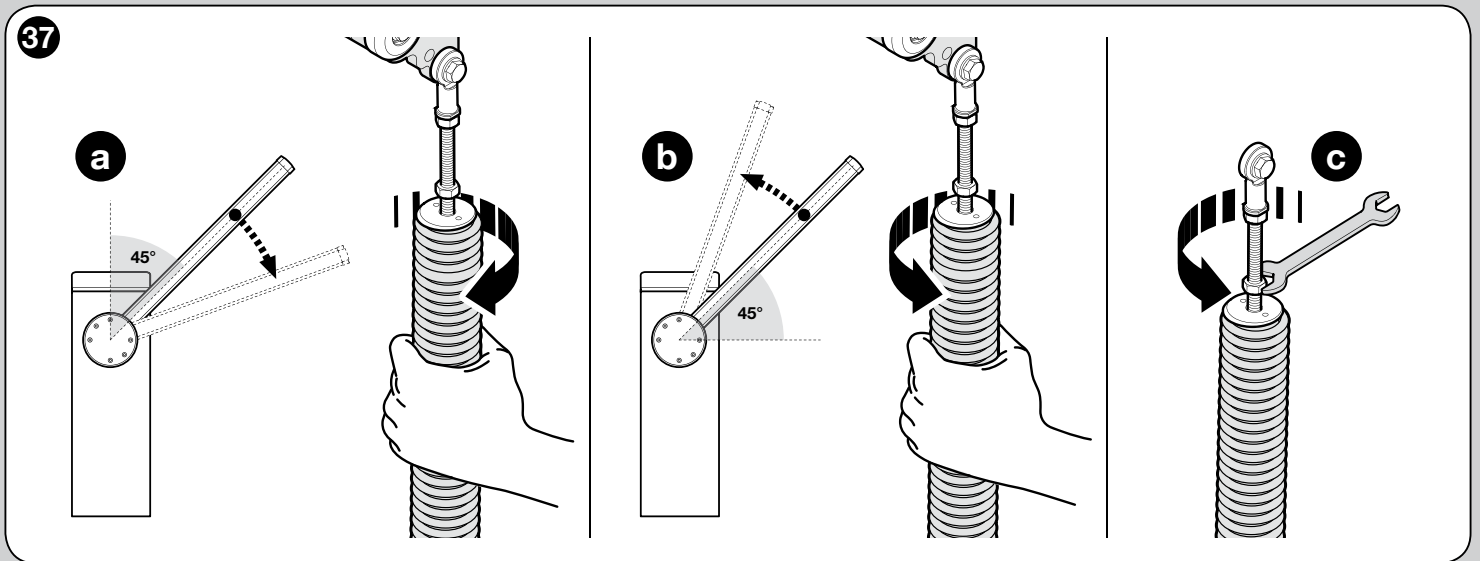
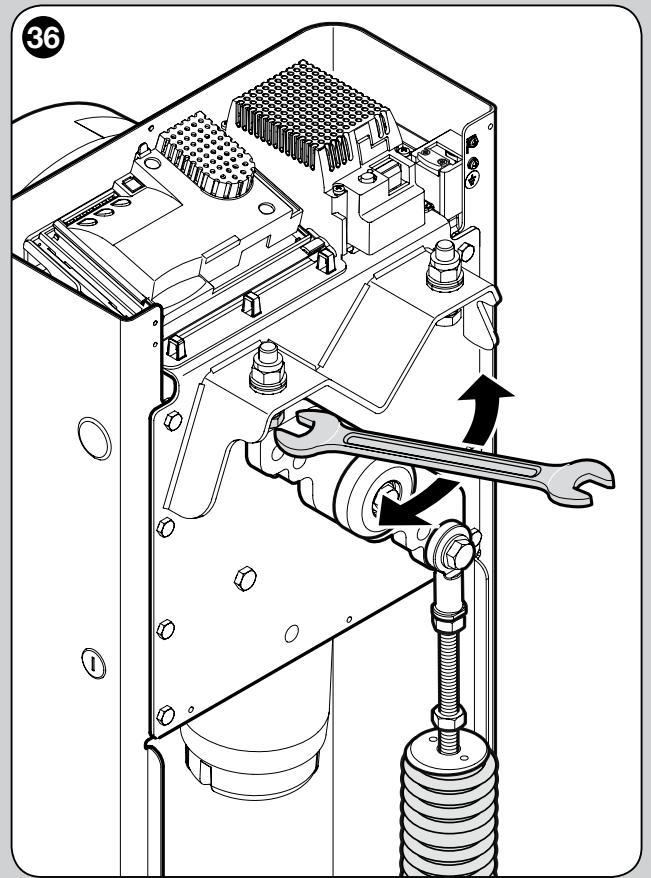
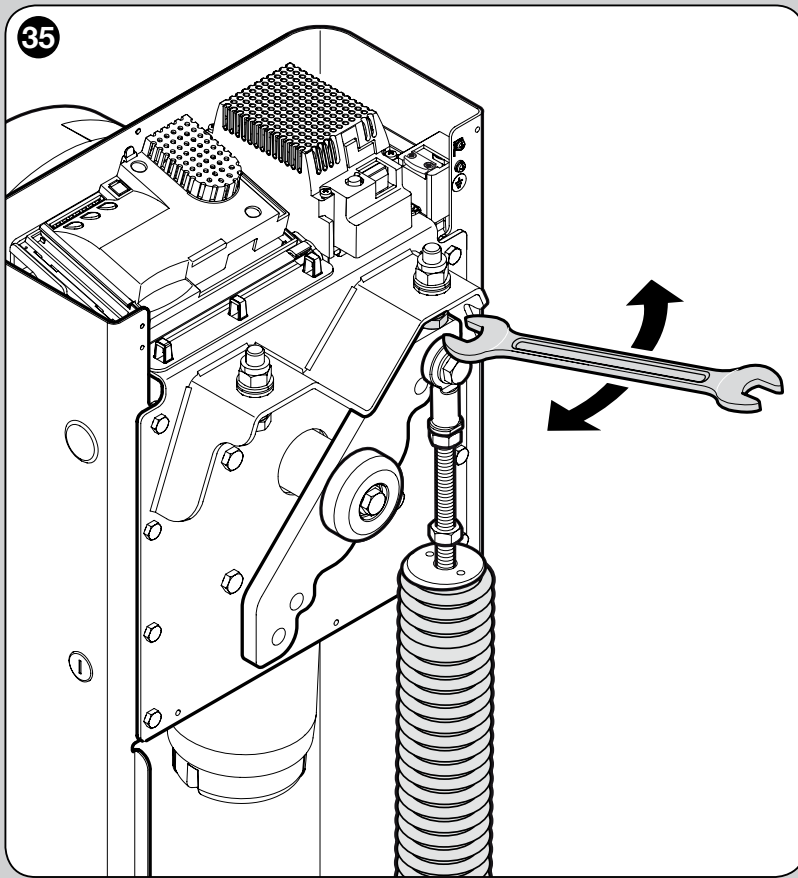

39

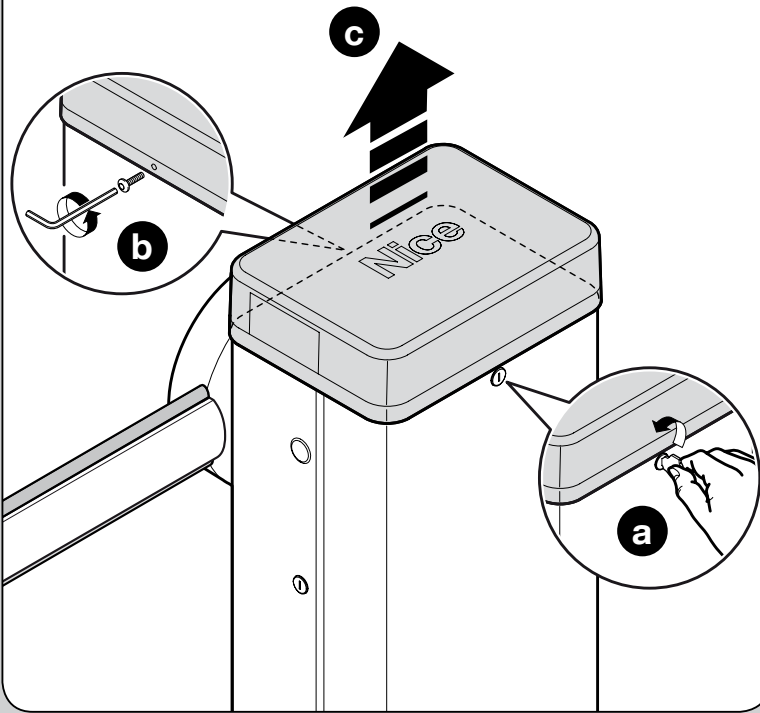

40

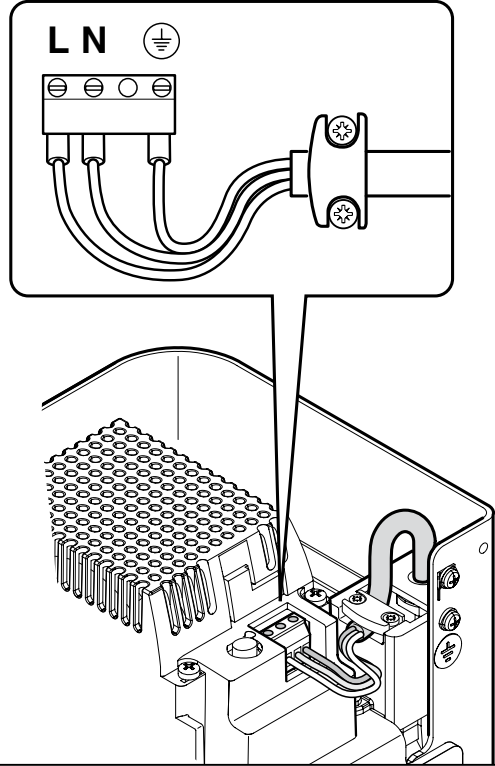

41

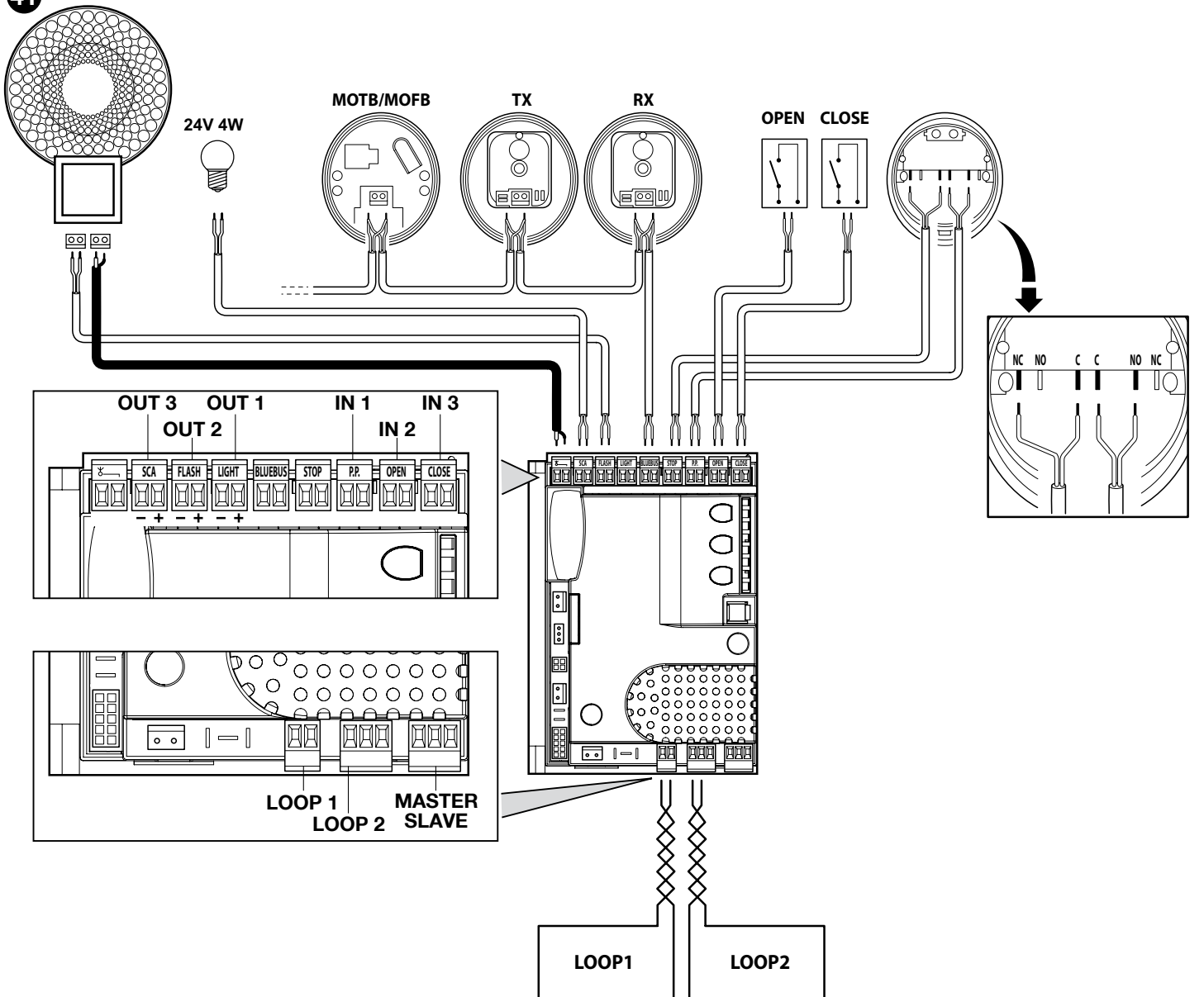

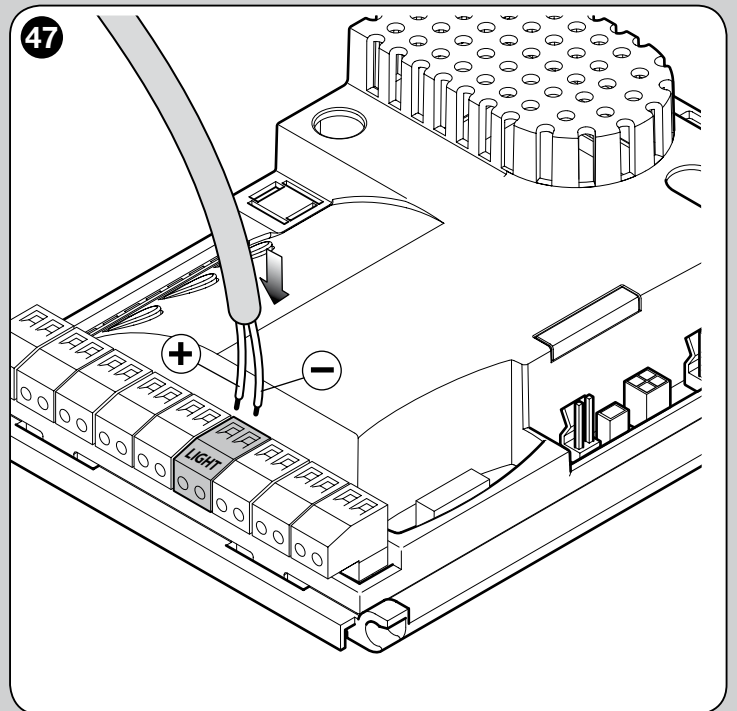
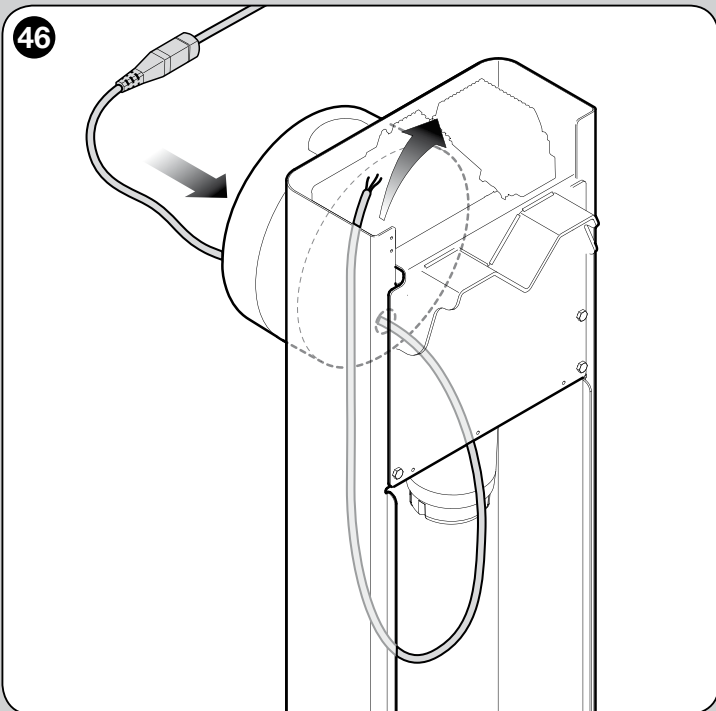
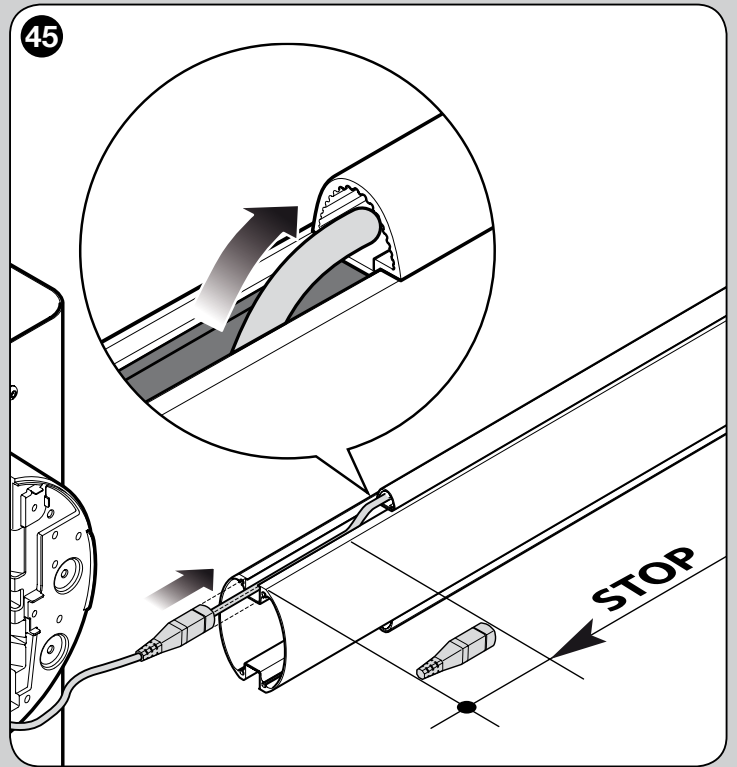
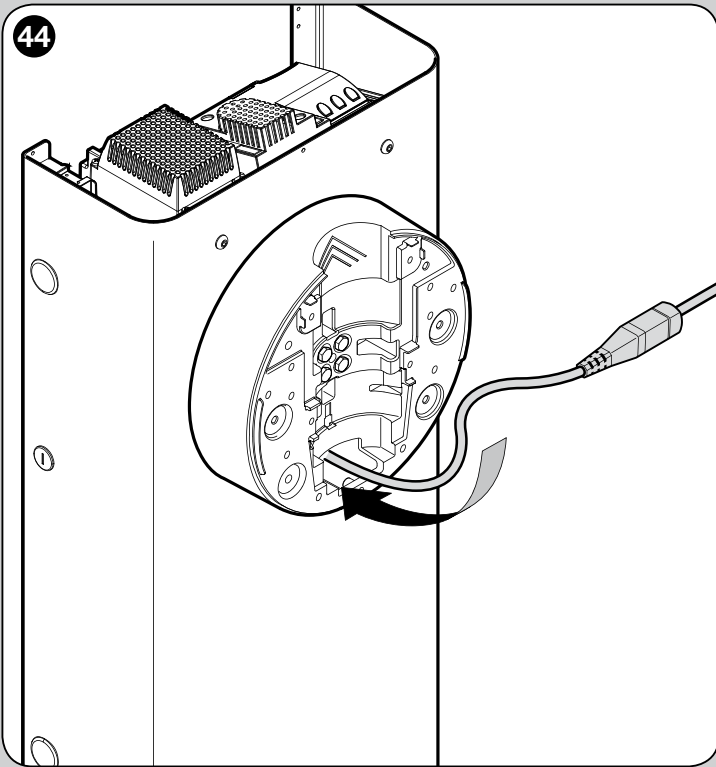
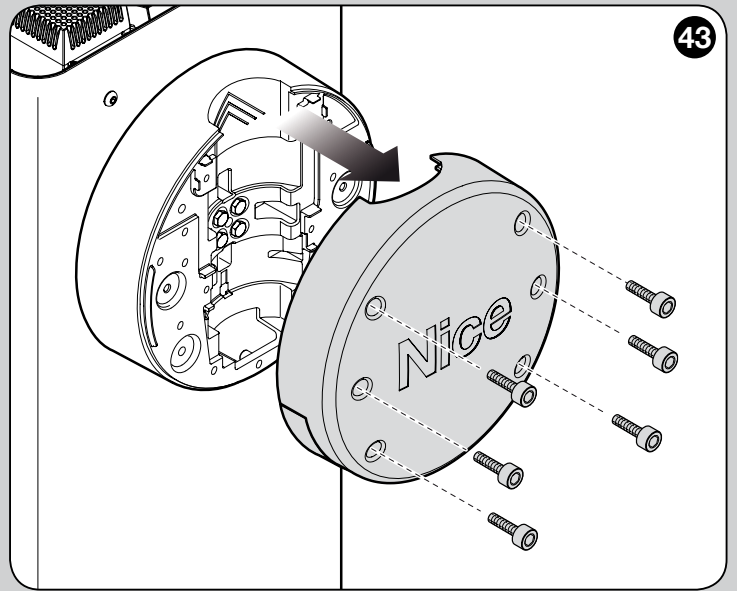
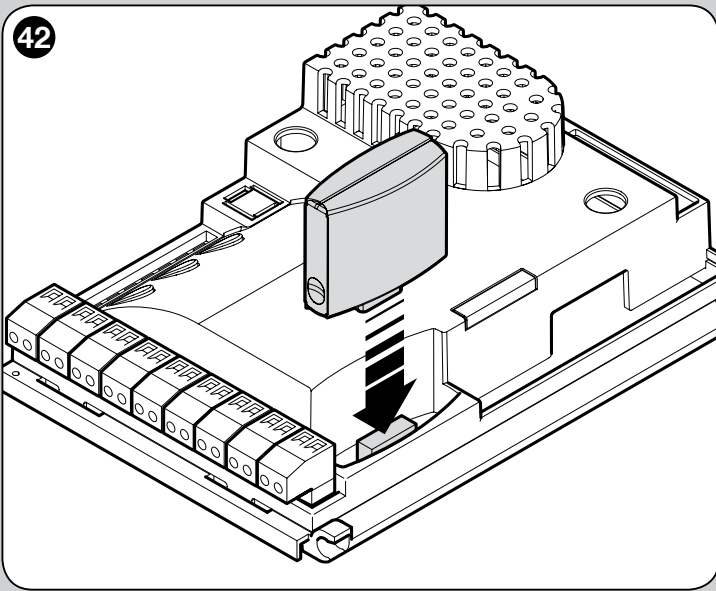

48

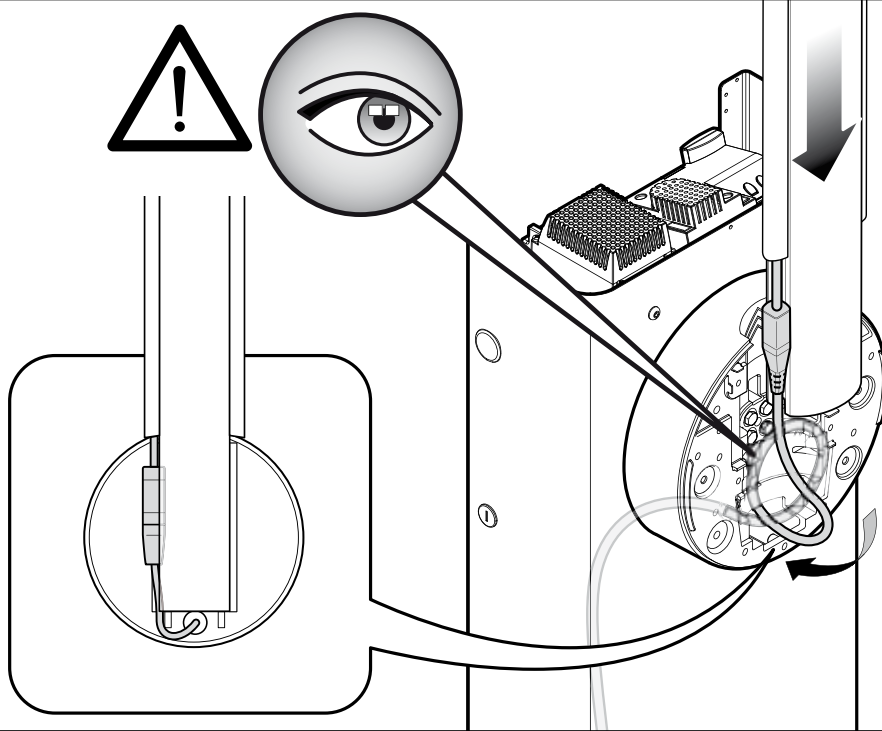

49

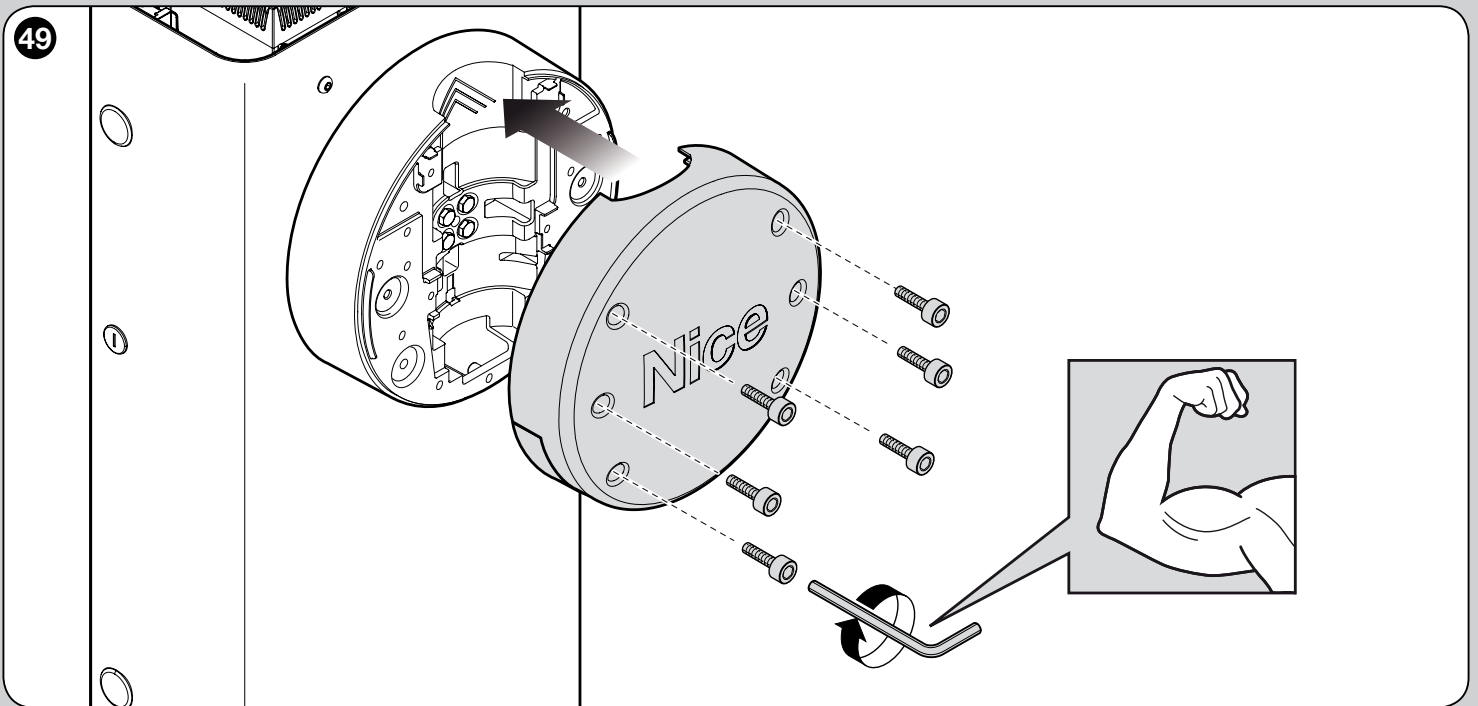

50

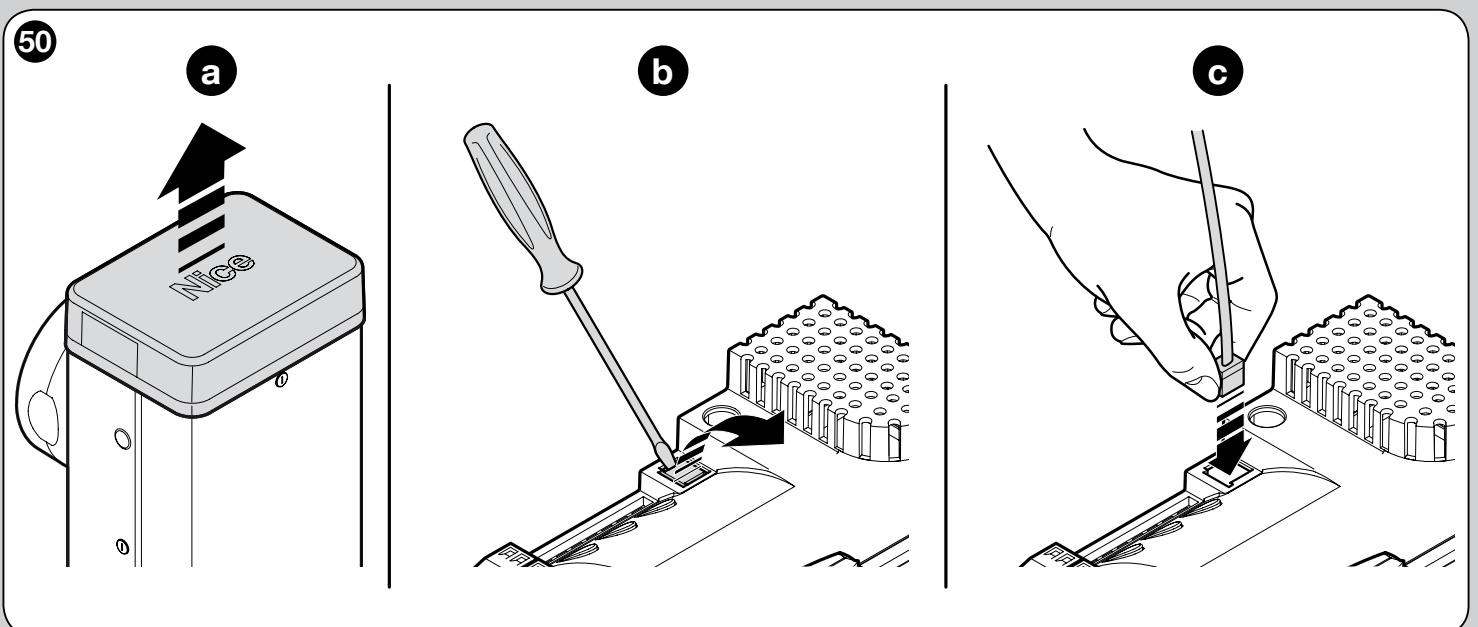

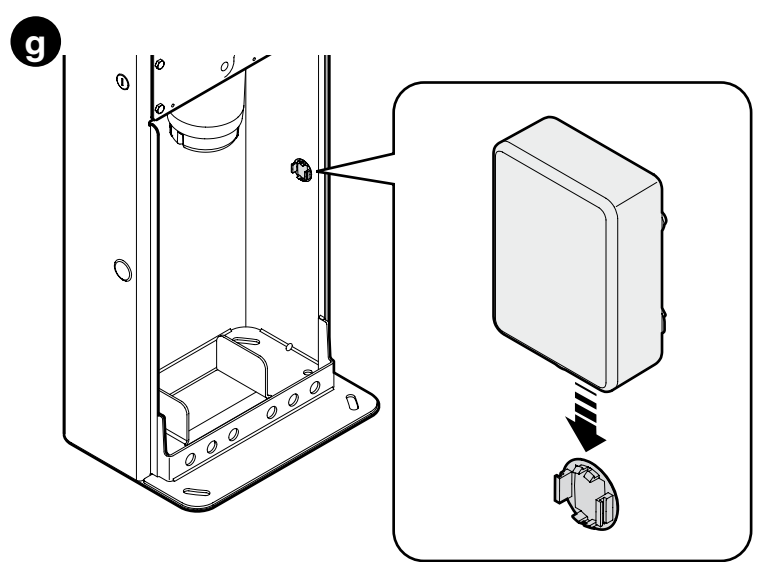
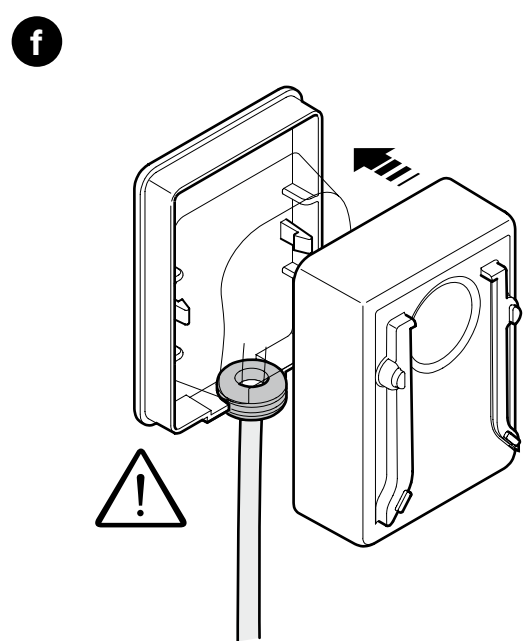
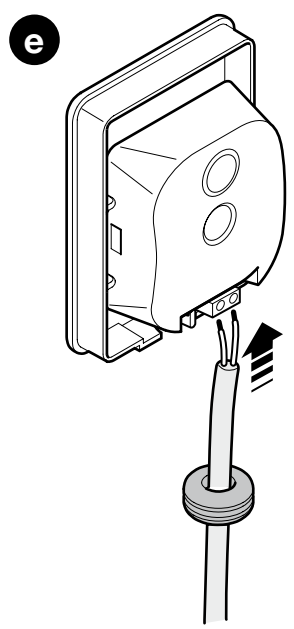
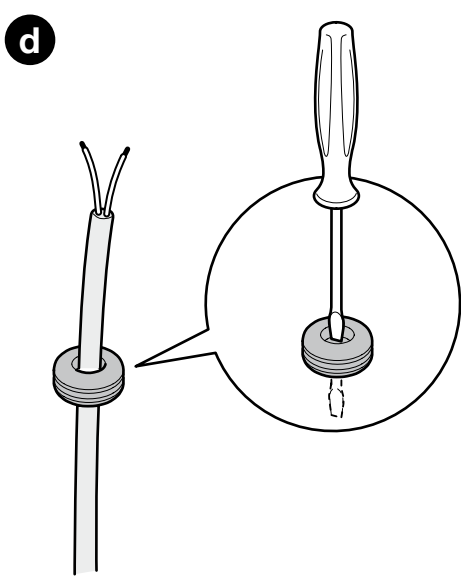
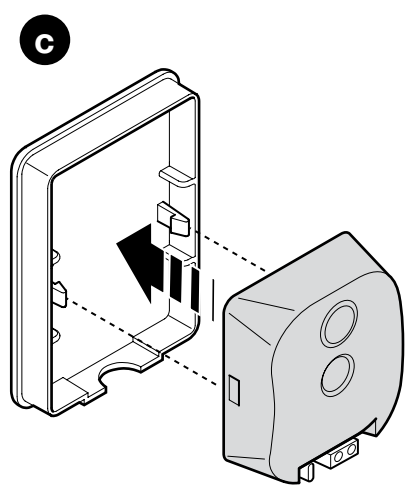
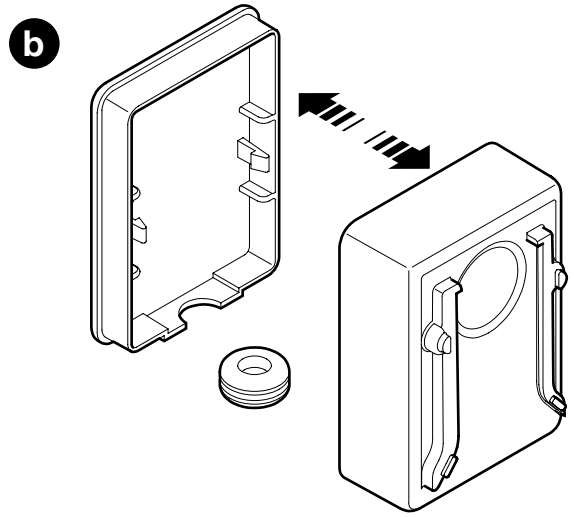
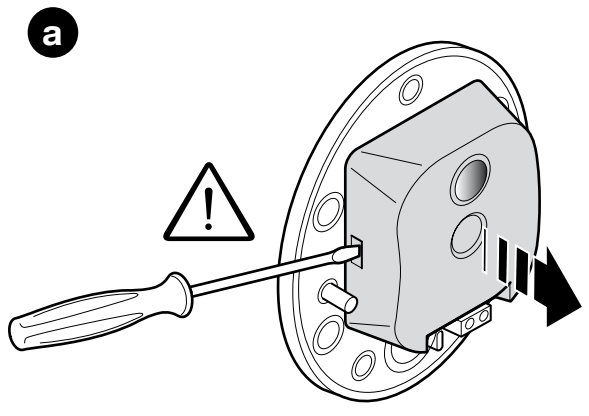

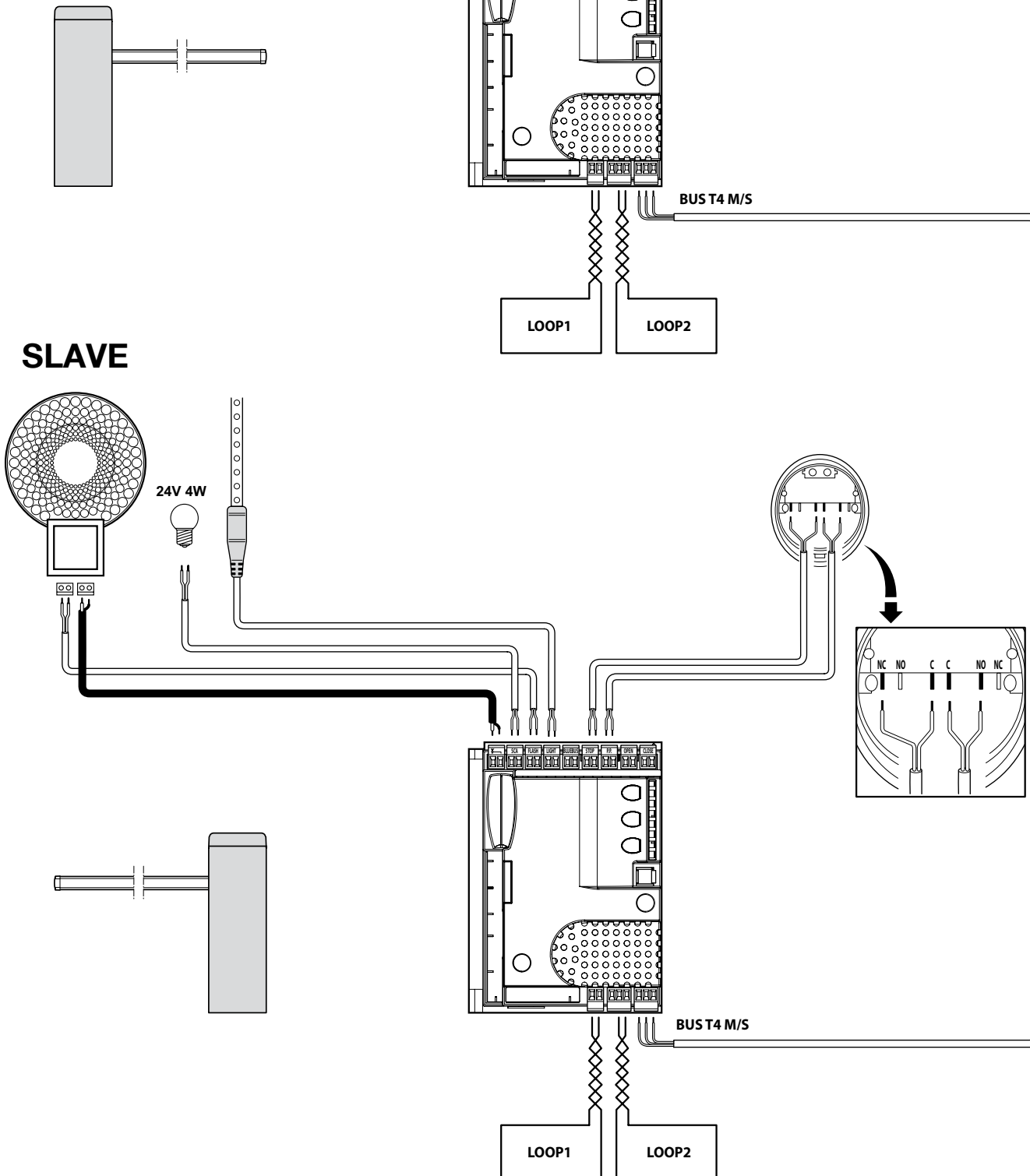
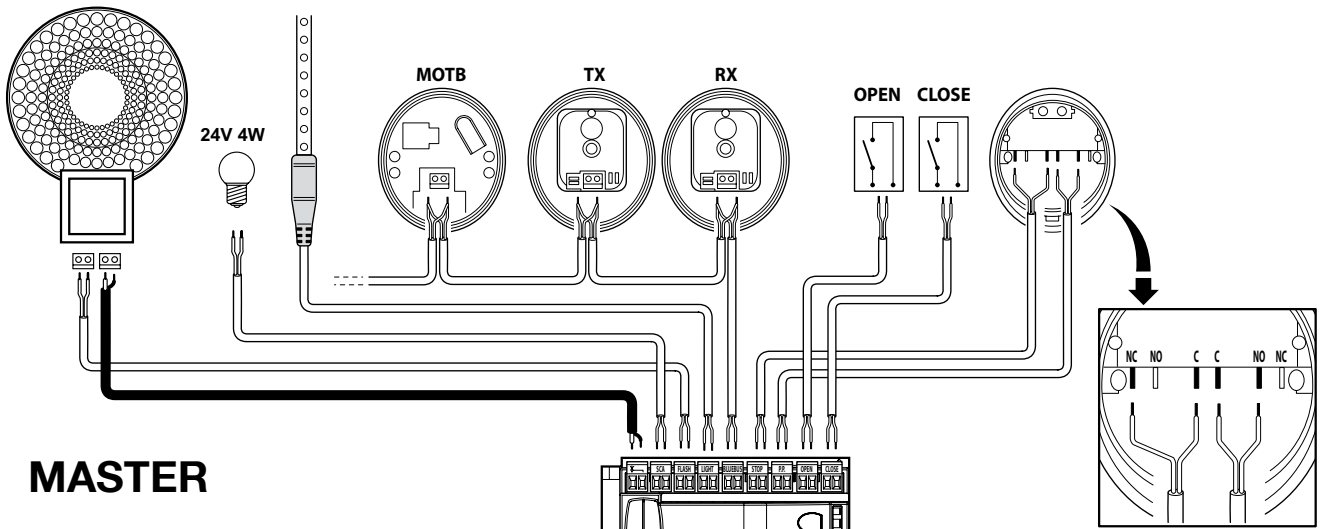

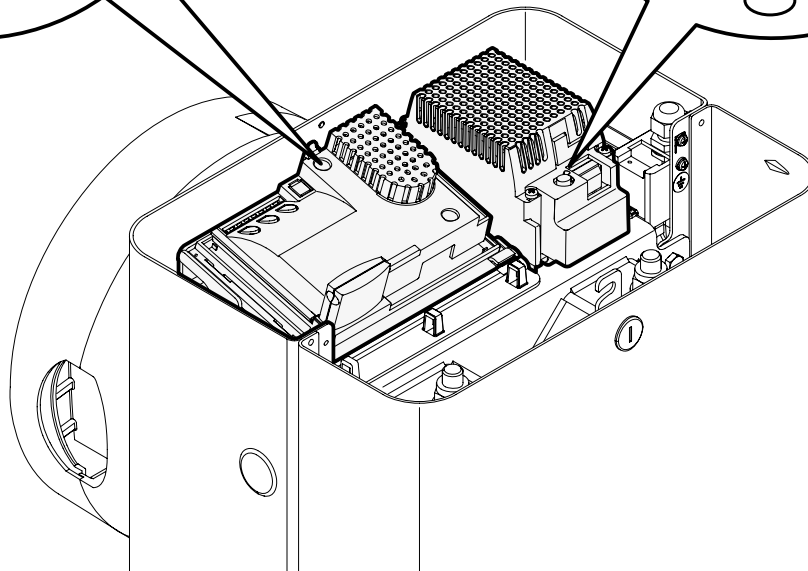
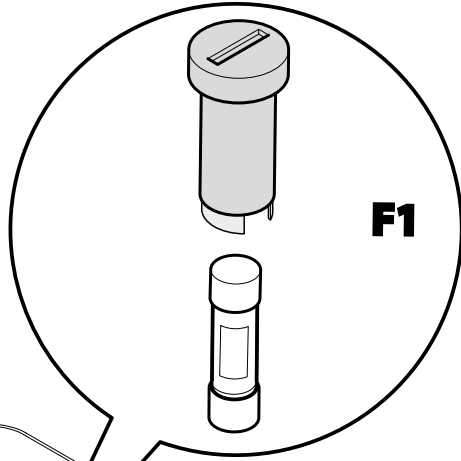
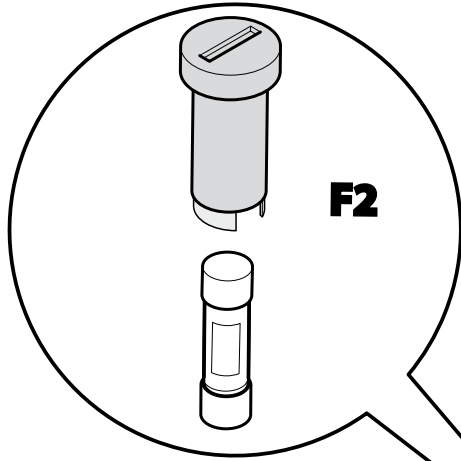



Nice SpA
Oderzo TV Italia
info@niceforyou.com

www.niceforyou.com